

# Advanced NG9-1-1 Recording Solution for Voice, SMS Text and Calltaker Screens

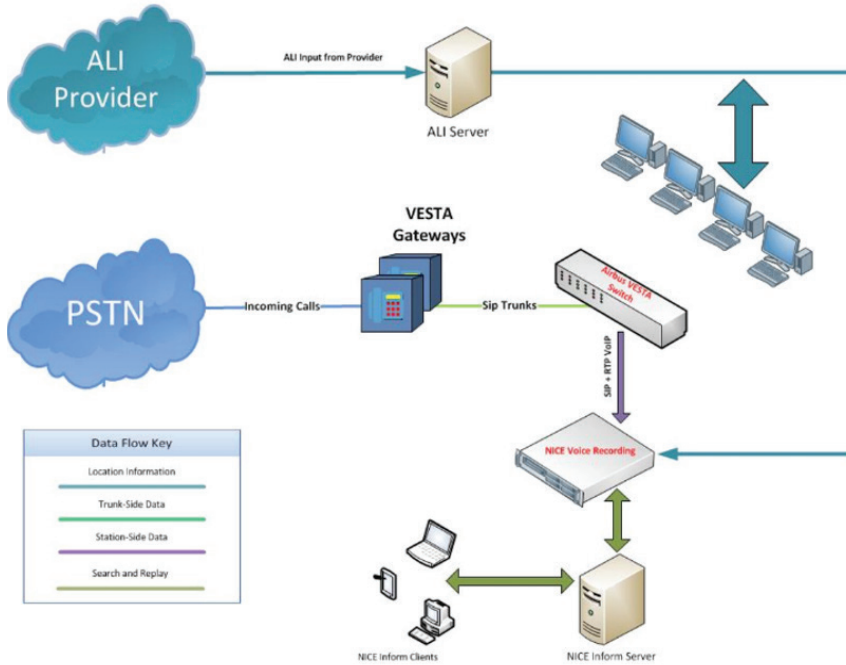

## VESTA<sup>®</sup> 9-1-1

Session Initiation Protocol (SIP) call handling with advanced Airbus DS Communications control, and robust mapping for streamlined NG9-1-1 call handling

## VESTA<sup>®</sup> SMS

NENA i3 aligned integrated Text-to-9-1-1 communications control

## NICE NRX Recording

Automated capture of voice, text, and console screen communications

## NICE Inform

Incident reconstruction, quality assurance and multimedia incident information management

The unique, certified integration of the Airbus VESTA 9-1-1/VESTA SMS solutions with NICE NRX and NICE Inform solutions delivers a unified, end-to-end solution for today's rapidly evolving emergency communications management, assuring readiness for tomorrow. The integration provides the software to record voice and SMS-to-911 (Text-to-911) communications and associated metadata directly from the VESTA 9-1-1 system.

### Proven, Tested End-to-end Solution

Integrated solution for managing, recording, analyzing and evaluating all types of communications including voice, text, screens and data. It improves compliance, training and support for investigations.

### Best-of-breed NG9-1-1 Technology

Proven technical and market leadership in successful deployments:

- 3,000+ NICE Inform systems installed worldwide
- 3,500+ Airbus VESTA systems at PSAPs across 48 US States

### Future-proof

Designed to NENA's i3 standards, assuring readiness for tomorrow.

### Easy Upgrade Path

Modular design provides flexibility to add powerful value-added applications: Screen Recording, Audio Analytics, Quality Assurance Evaluation, and more



## Captured Metadata for Precision Searches

In addition to Caller Number and Location information, metadata information also includes Position Number of the Call Taker. This is used to 'Link' the Voice, SIP and Location information together and can be used to quickly find audio call, text and screen captures for any specific incident.

## Advanced Text-to-911 Logging

The VESTA SMS solution allows designated agents to simultaneously manage SMS conversations and voice calls. The entire conversation, as well as call and message data including agent/position information, are logged. The VESTA SMS solution is NENA i3 aligned and compliant with the Joint Alliance for Telecommunications Industry Solutions (ATIS) and the Telecommunications Industry Association (TIA) J-STD-110.

## Redundant Configurations for High Reliability

Whether deployed at a single site or in multi-site configurations, the recommended design of the recording solution, including capture, storage, and archiving, is a resilient, fully redundant configuration that eliminates the vulnerability of any single point of failure.

This is coupled with intelligent replay of redundant recordings – NICE Inform makes playback transparent to users so they do not need to deal with multiple copies of the same recording in their search results. NICE Inform automatically displays the primary or the secondary (redundant) record, depending on which is available.

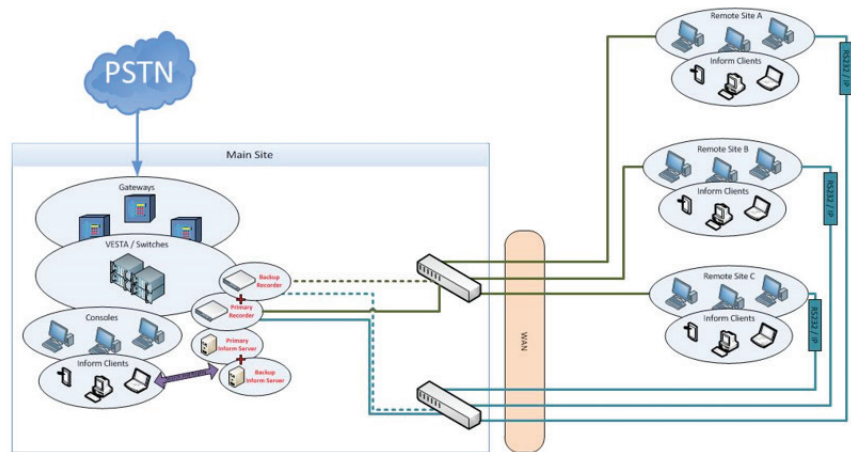

With resilient solutions, all applications for replay, reconstruction, organization, evaluation, analytics and media distribution are available for use at all times, without interruptions

## Interface Protocols

Audio
Standard (Passive) RTP VoIP

Signalling, Messaging, Metadata
SIP

Location
ANI/ALI (RS232 / IP)

## About NICE Public Safety

NICE Public Safety solutions integrate and put into context information from many sources to help emergency communications centers and investigation departments reconstruct and understand the who, what, when, where and why of an incident. NICE Inform, the industry-leading digital evidence management (DEM) solution, gives emergency communications centers better insight into how to continuously improve their operations. NICE Investigate is the leading open, digital policing solution that automates and expedites the entire digital investigation process, helping to increase case clearance rates. Over 3,000 organizations worldwide rely on NICE Public Safety solutions. [www.nice.com](http://www.nice.com)

## About Airbus DS Communications, Inc.

Airbus DS Communications, an Airbus Defense and Space Holdings, Inc. company, is a global leader and trusted source for mission-critical communications technologies. The VESTA® product suite provides Next Generation 9-1-1 call processing systems, land mobile radio solutions and emergency notification applications, creating smarter ways to keep all our communities safe.