

FIRE ACCESS PLAN

LOTS 1, 2, & 3 OF HERCULES PARK ADDITION

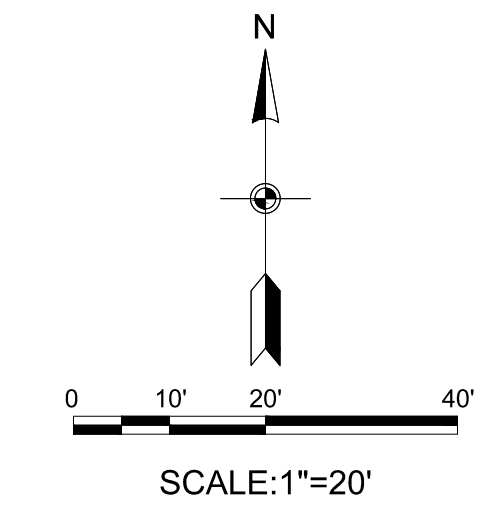

LEGEND:

- PROPERTY LINE
- LOT DIVISION
- EXISTING WATER SERVICE

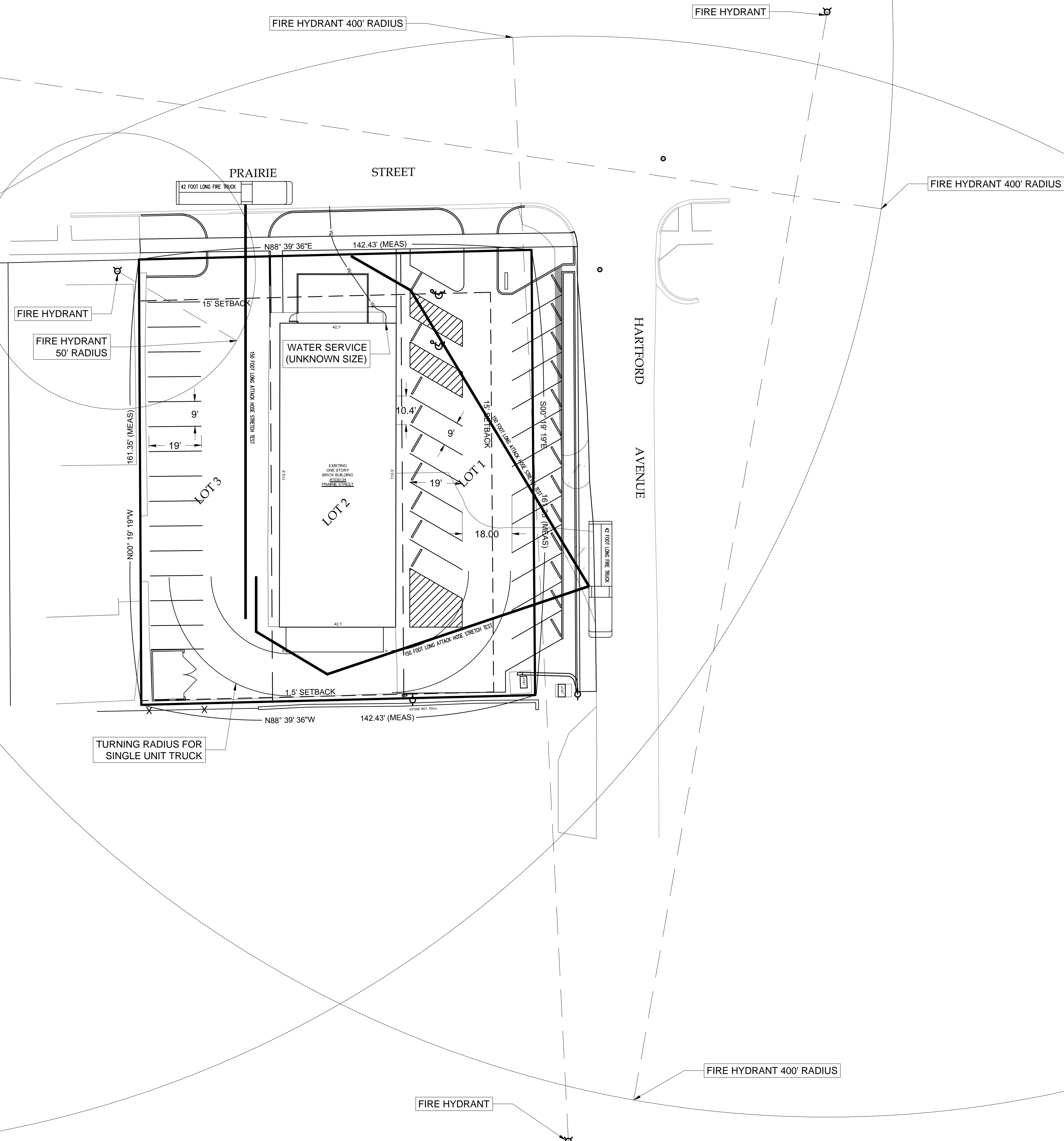

Fire Access Plan Data Table		
Description	Value	Unit
a) Building Height	22.00	feet
b) Square footage of each building	4.632	feet
c) Building fire suppression information including any proposed use of sprinkler systems, fire alarm systems, whether fire extinguishers are needed:		
No sprinkler system. Fire alarm and fire extinguishers to be provided per code.		
d) General description of business to be conducted within each building including: will there be rack storage in the building, will there be storage of combustible materials over twelve feet in height, clearance of sprinkler heads and stored materials (18 inch minimum):		
Tavern		

DESIGNED BY:	DATE:	DEVELOPER:
MICHAEL POUKANDAS	2015-03-07	KONRAD CONSTRUCTION
CHKD BY:		348 N LAKE STREET
PROJECT:		JAUPORA, IL 60608
DATE:		
DESCRIPTION:		

SPARTAN HOUSE
FINAL PLAN FOR LOTS
1, 2, & 3 OF HERCULES
ADDITION

DRAWING
NUMBER
C-1001
SHEET 2 OF 3

rbac

RB & ASSOCIATES
CONSULTING, INC
 4 W MAIN STREET PLANO, IL 60545
 DESIGN FIRM # 184-004475

FINAL PLAN