

FIRE ACCESS PLAN FOR MELODY TOWN CENTER - PHASE I (LOT 1)

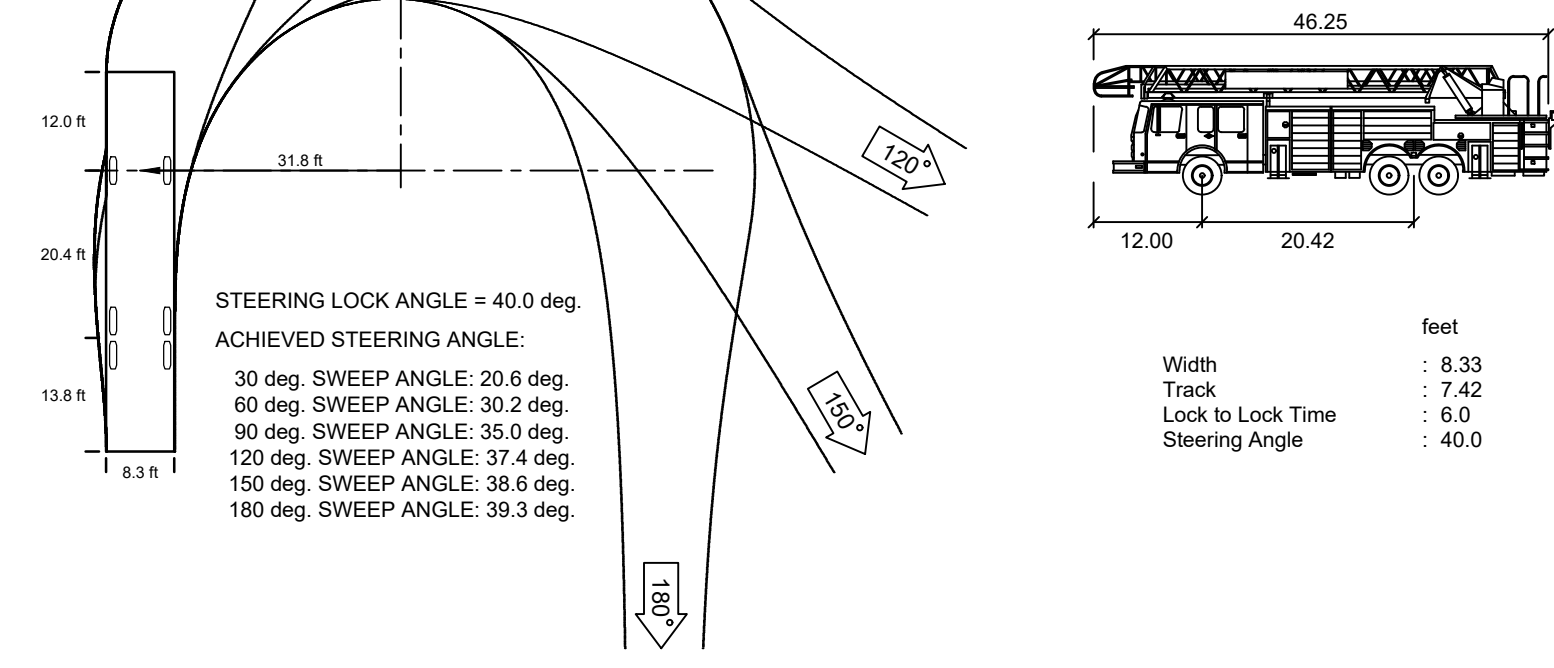
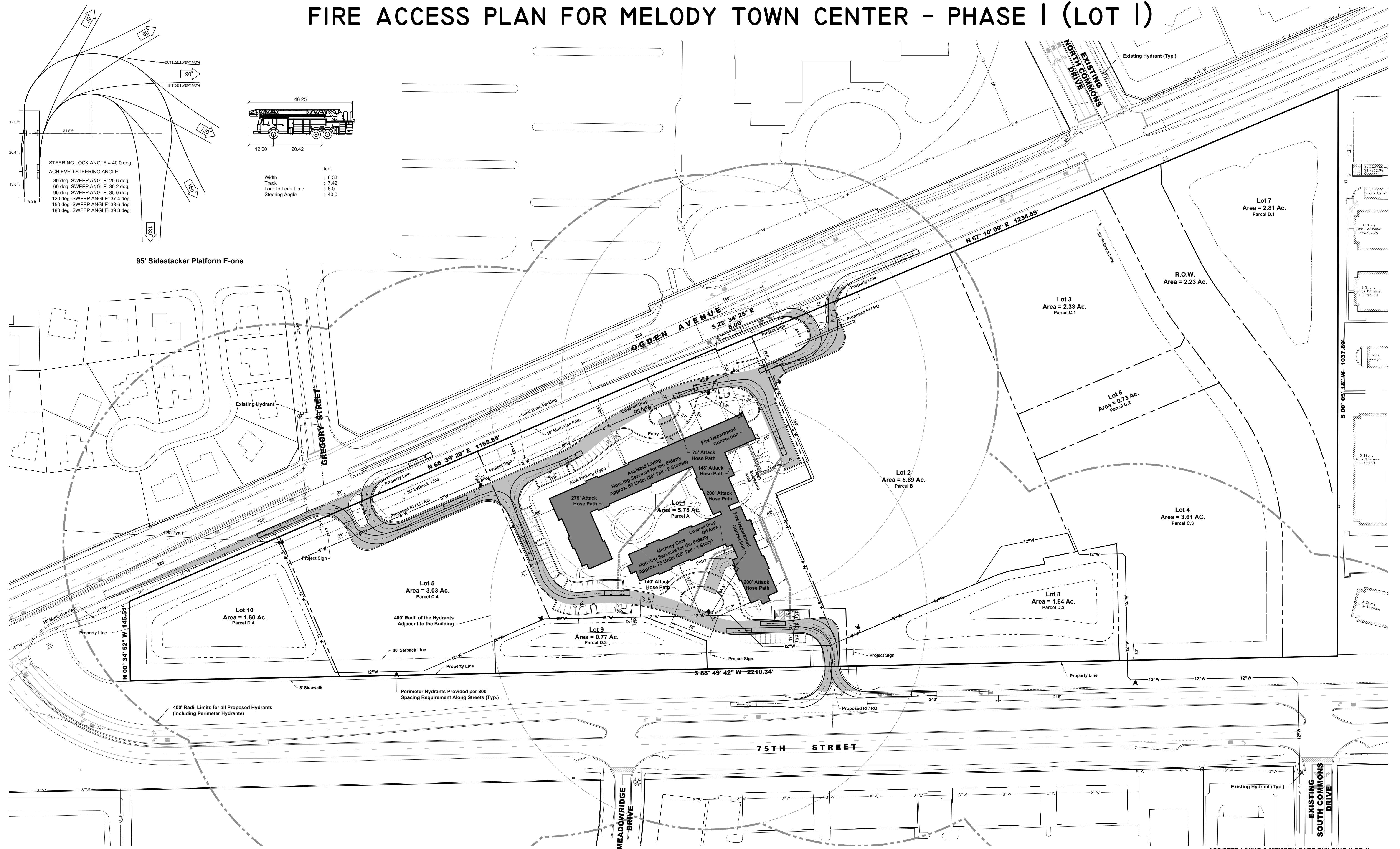

- LEGEND**
- FIRE LANE
 - LIMITS OF VEHICLE
 - FIRE HYDRANT
 - ATTACK HOSE PATH

ASSISTED LIVING & MEMORY CARE BUILDING (LOT 1)

Fire Access Plan Data Table

Description	Value	Unit
a) Building Height	29.17	feet
b) Building Square Footage (typical)	Approx. 85,000	square feet
c) Building fire suppression information including any proposed use of sprinkler systems, fire alarm systems, whether fire extinguishers are needed: Both the Assisted Living & Memory Care buildings are to be fully sprinklered.		
d) General description of business to be conducted within each building including: will there be rack storage in the building, will there be storage of combustible materials over twelve feet in height, clearance of sprinkler heads and stored materials (18 inch minimum): Both the Assisted Living & Memory Care buildings are to provide housing services to the elderly. Note: the Assisted Living building is two stories tall and has a pitched roof with a mean height of 29'-2". The Memory Care building is one story and is shorter than the Assisted Living building.		

NOTES

- All dimensions shown are to back of curb unless otherwise noted. Building ties, where shown, are normal to lot lines.
- Building use descriptions for AL and IL buildings are from City of Aurora Planning and Zoning Division Table One: Use Categories. *1200 Housing services for the elderly.*

Cedarwood Development
 1705 MERRIMAN ROAD
 AKRON, OHIO 44313
 P: 330-836-9871
 F: 330-836-4591

Contract Purchaser & Petitioner:
 Laura Heister, Housing
 Ron DiHarbo
 (330) 714-9617
 (330) 414-6315

HAEGER ENGINEERING
 consulting engineers • land surveyors
 100 East State Parkway, Schaumburg, IL 60173 • Tel: 847.394.6600 Fax: 847.394.6698
 Illinois Professional Design Firm License No. 184-003142
 www.haegerengineering.com

No.	Date	Revision
1	2019.07.09	Revised per Preliminary City Review Comments

FIRE ACCESS PLAN FOR MELODY TOWN CENTER - PHASE I

MELODY TOWN CENTER CEDARWOOD DEVELOPMENT
 CITY OF AURORA, DUPAGE COUNTY, ILLINOIS

Project Manager: J D T
 Engineer: M D M
 Date: 2019-06-12
 Project No. 17-131
 Sheet 1/2

FIRE ACCESS PLAN FOR MELODY TOWN CENTER - PHASE 2 (LOTS 1 & 2)

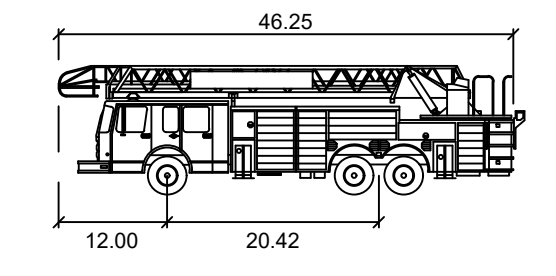
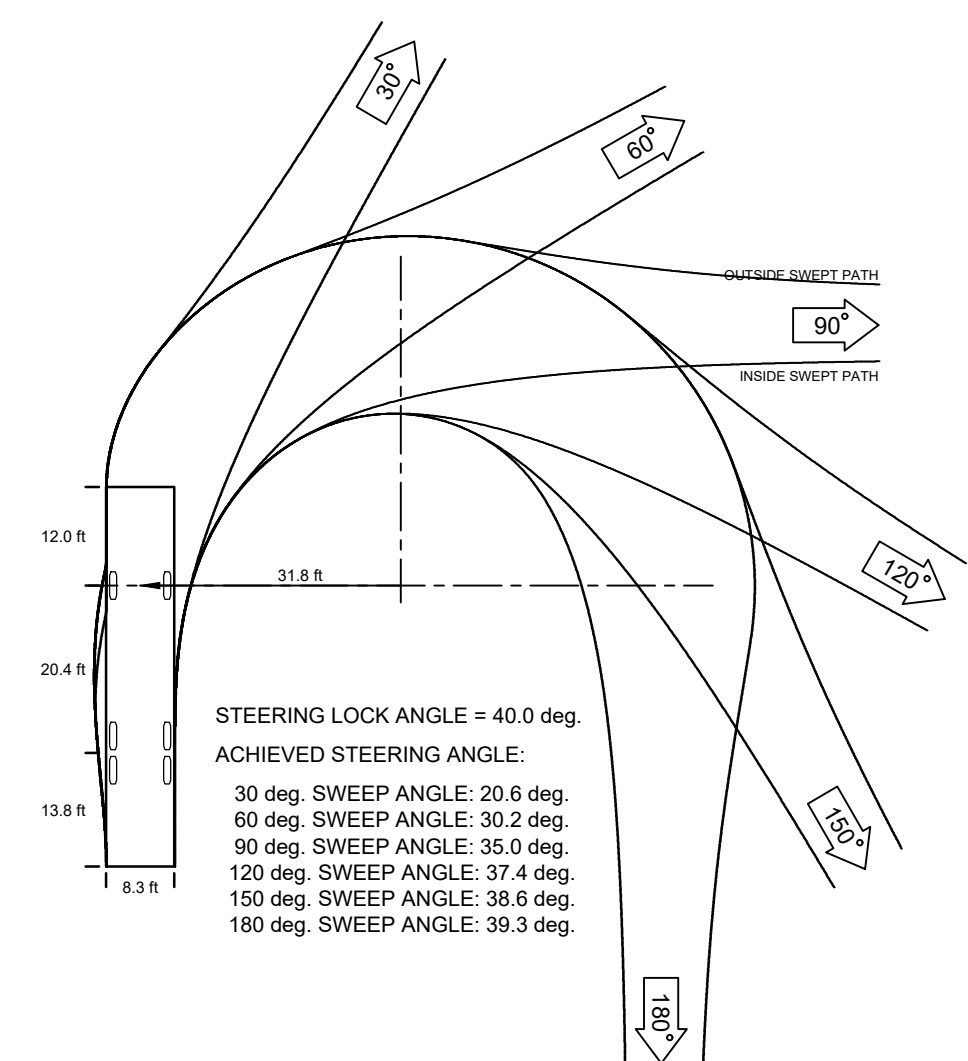
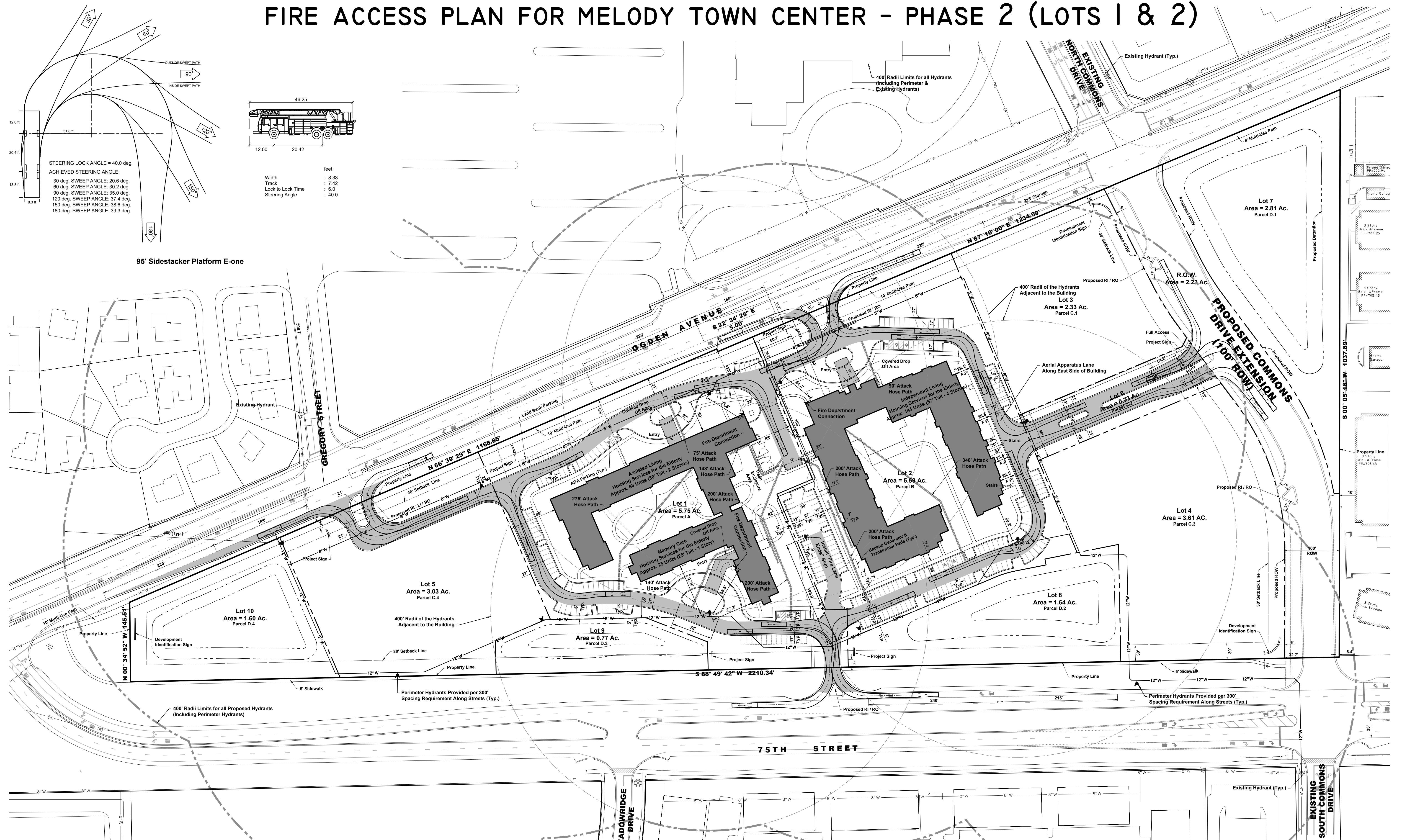

- LEGEND**
- FIRE LANE
 - LIMITS OF VEHICLE
 - FIRE HYDRANT
 - ATTACK HOSE PATH

NOTES

- All dimensions shown are to back of curb unless otherwise noted. Building ties, where shown, are normal to lot lines.
- Building use descriptions for AL and IL buildings are from City of Aurora Planning and Zoning Division Table One: Use Categories: *1200 Housing services for the elderly.

ASSISTED LIVING & MEMORY CARE BUILDING (LOT 1)

Fire Access Plan Data Table

Description	Value	Unit
a) Building Height	29.17	feet
b) Building Square Footage (typical)	Approx. 85,000	square feet
c) Building fire suppression information including any proposed use of sprinkler systems, fire alarm systems, whether fire extinguishers are needed: Both the Assisted Living & Memory Care buildings are to be fully sprinklered.		
d) General description of business to be conducted within each building including: will there be rack storage in the building, will there be storage of combustible materials over twelve feet in height, clearance of sprinkler heads and stored materials (18 inch minimum): Both the Assisted Living & Memory Care buildings are to provide housing services to the elderly. Note: the Assisted Living building is two stories tall and has a pitched roof with a mean height of 29'-2". The Memory Care building is one story and is shorter than the Assisted Living building.		

INDEPENDENT LIVING BUILDING (LOT 2)

Fire Access Plan Data Table

Description	Value	Unit
a) Building Height	37.00	feet
b) Building Square Footage (typical)	Approx. 200,000	square feet
c) Building fire suppression information including any proposed use of sprinkler systems, fire alarm systems, whether fire extinguishers are needed: The Independent Living building is to be fully sprinklered.		
d) General description of business to be conducted within each building including: will there be rack storage in the building, will there be storage of combustible materials over twelve feet in height, clearance of sprinkler heads and stored materials (18 inch minimum): The Independent Living building is to provide housing services to the elderly.		

Contract Purchaser & Petitioner:

Cedarwood Development

1705 MERRIMAN ROAD
 AKRON, OHIO 44313
 P: 330-836-9871
 F: 330-836-4591

Ron Dharwad
 Laura Heister
 Housing Development
 (330) 714-9617

HAEGER ENGINEERING
 consulting engineers • land surveyors

100 East State Parkway, Schaumburg, IL 60173 • Tel: 847.394.6600 Fax: 847.394.6608
 Illinois Professional Design Firm License No. 184-003142
 www.haegerengineering.com

Contract Purchaser & Petitioner:

Cedarwood Development

1705 MERRIMAN ROAD
 AKRON, OHIO 44313
 P: 330-836-9871
 F: 330-836-4591

Ron Dharwad
 Laura Heister
 Housing Development
 (330) 714-9617

FIRE ACCESS PLAN FOR MELODY TOWN CENTER - PHASE 2

MELODY TOWN CENTER CEDARWOOD DEVELOPMENT

CITY OF AURORA, DUPAGE COUNTY, ILLINOIS

Project Manager: J D T
 Engineer: M D M
 Date: 2019-06-12
 Project No. 17-131
 Sheet 2/2