

FIRE ACCESS PLAN FOR SAVANNAH CROSSING SUBDIVISION - LOT 9

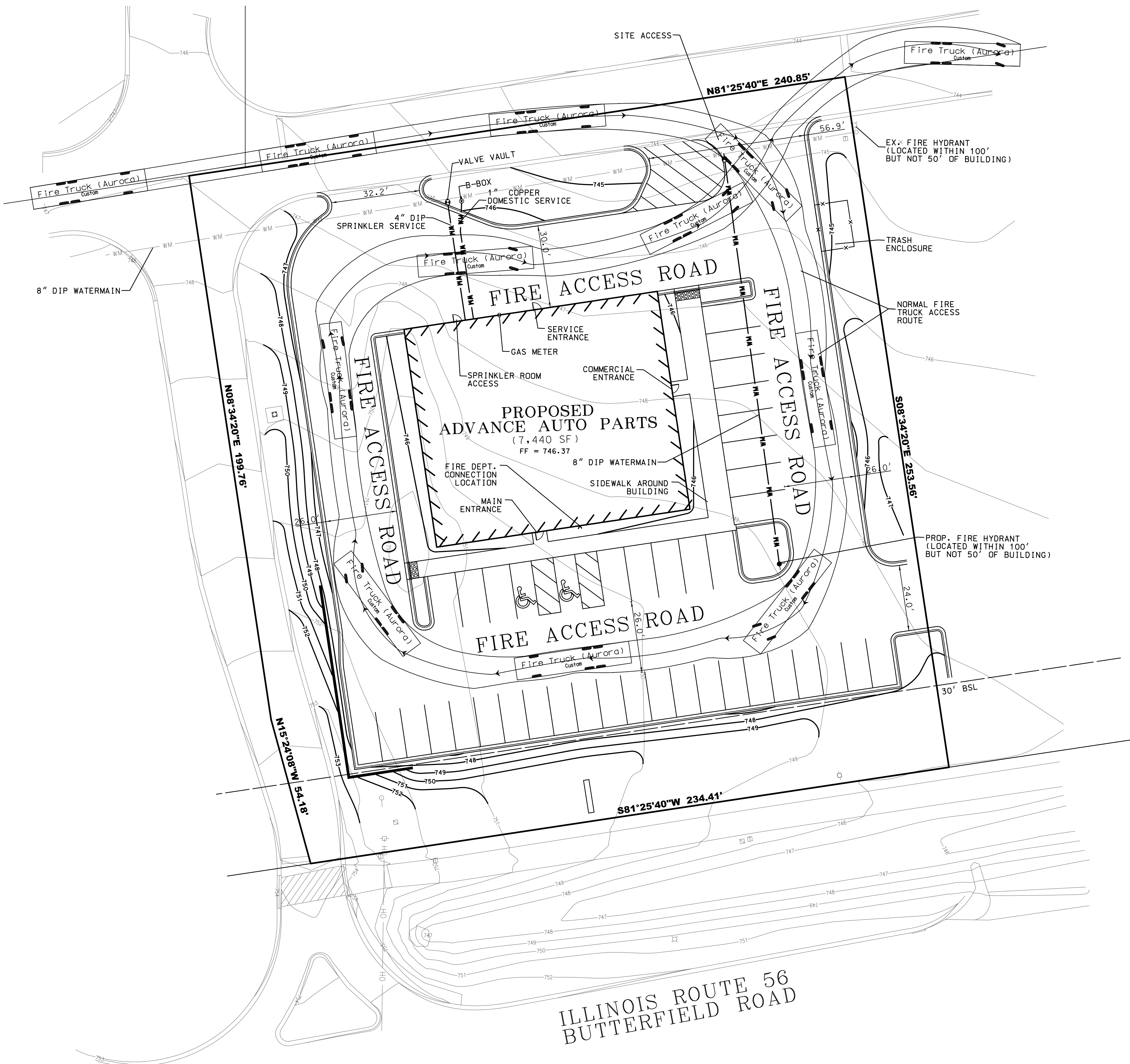

LEGEND	
EXISTING	PROPOSED
8" PVC	8" PVC
12" RCP	12" RCP
UD	UD
Manhole	Manhole
Catch Basin	Catch Basin
Inlet	Inlet
Cleanout	Cleanout
Water Main	Water Main
Valve Vault	Valve Vault
Valve Box	Valve Box
Fire Hydrant	Fire Hydrant
Flared End Section	Flared End Section
Combined Sewer	Combined Sewer
Street Light/Parking Lot Light	Street Light/Parking Lot Light
Power Pole	Power Pole
Street Sign	Street Sign
Fence	Fence
Gas Main	Gas Main
Overhead Line	Overhead Line
Telephone Line	Telephone Line
Electric Line	Electric Line
Cable TV Line	Cable TV Line
High Water Level	High Water Level
Normal Water Level	Normal Water Level
Contour Line	Contour Line
Top of Curb Elevation	Top of Curb Elevation
Top of Depressed Curb	Top of Depressed Curb
Pavement Elevation	Pavement Elevation
Spot Elevation	Spot Elevation
Finished Floor Elevation	Finished Floor Elevation
Top of Foundation	Top of Foundation
Grade at Foundation	Grade at Foundation
High or Low Point	High or Low Point
Overland Flood Route	Overland Flood Route
Pavement Flow Direction	Pavement Flow Direction
Swale Flow Direction	Swale Flow Direction
Depressed Curb and Gutter	Depressed Curb and Gutter
Reverse Curb and Gutter	Reverse Curb and Gutter

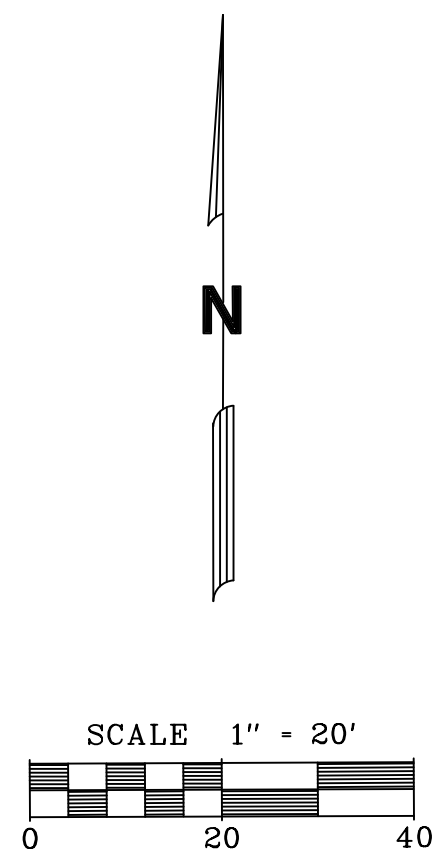
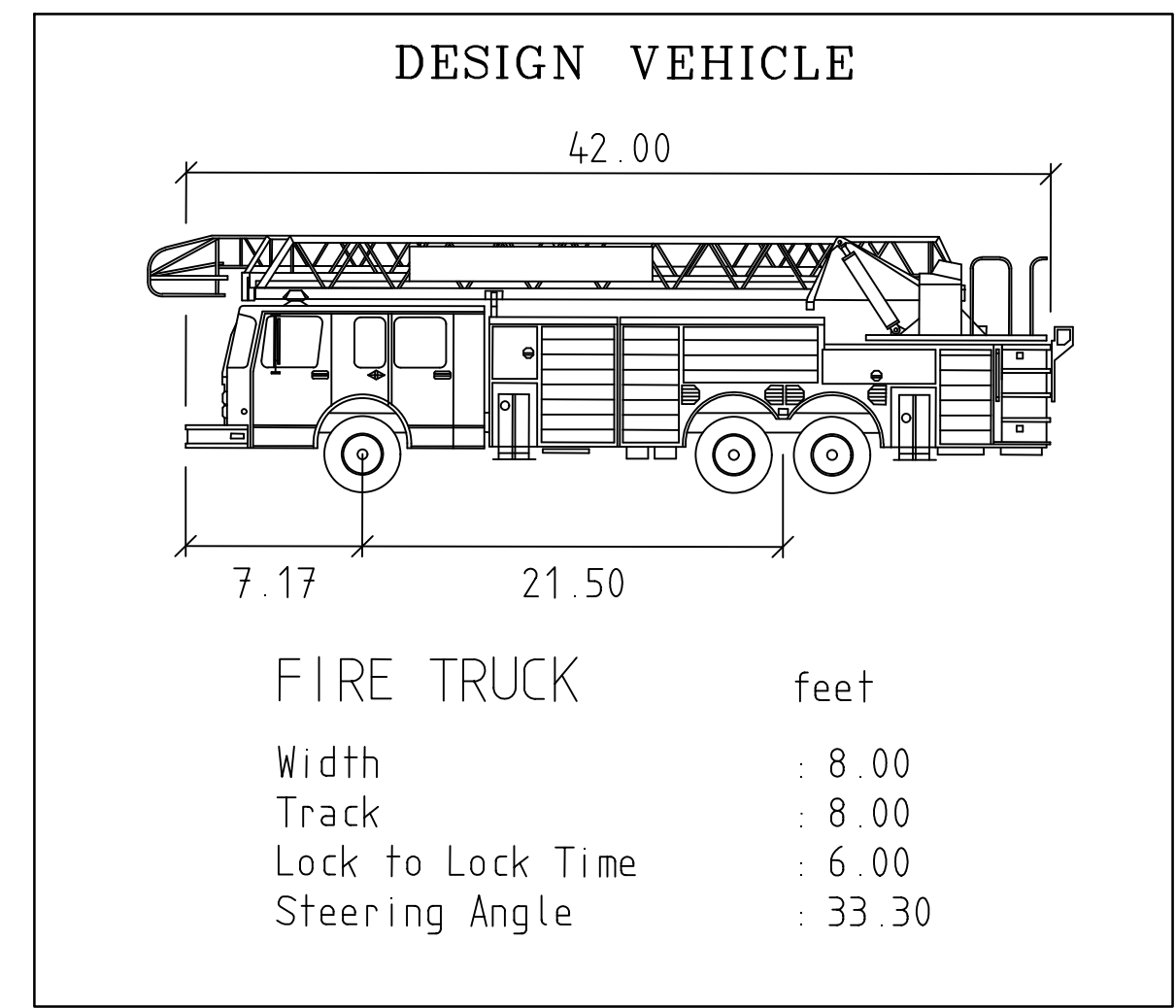

SITE DATA TABLE:

- BUILDING HEIGHT: 20' - 10"
- BUILDING AREA: 7,440 S.F.
- FULL FIRE SUPPRESSION AND ALARM SYSTEM.
- MINIMUM OF 4 EXTINGUISHERS PROVIDED
- NO COMBUSTIBLE MATERIALS STORED ABOVE 12' IN HEIGHT
- 18' MINIMUM SPRINKLER HEAD CLEARANCE

6/17/2015 9:06:22 AM M:\2691\Engineering\Projects\Fire_Plan\pt

Mackie Consultants, LLC
 9575 W. Higgins Road, Suite 500
 Rosemont, IL 60018
 (847)696-1400
 www.mackieconsult.com

CLIENT:
CAMBURAS & THEODORE
 2454 E DEMPSTER ST
 DES PLAINES, ILLINOIS 60016

DESIGNED	KEH
DRAWN	KEH
APPROVED	DAS
DATE	6-2-15
SCALE	1" = 20'
6-16-15	REVISED PER INITIAL CITY COMMENTS
DATE	DESCRIPTION OF REVISION
	KEH
	BY

FIRE PLAN
SAVANNAH CROSSING SUBDIVISION - LOT 9
AURORA, ILLINOIS

SHEET
1 OF 1
 PROJECT NUMBER: 2691
 © MACKIE CONSULTANTS, LLC, 2015
 ILLINOIS FIRM LICENSE 184-002694