

**FIRE ACCESS PLAN**  
**FOR**  
**LOT 6 OF PODOLSKY ORCHARD 88 PHASE 1**

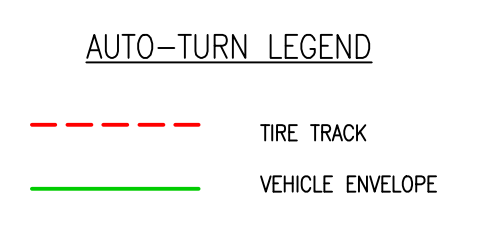
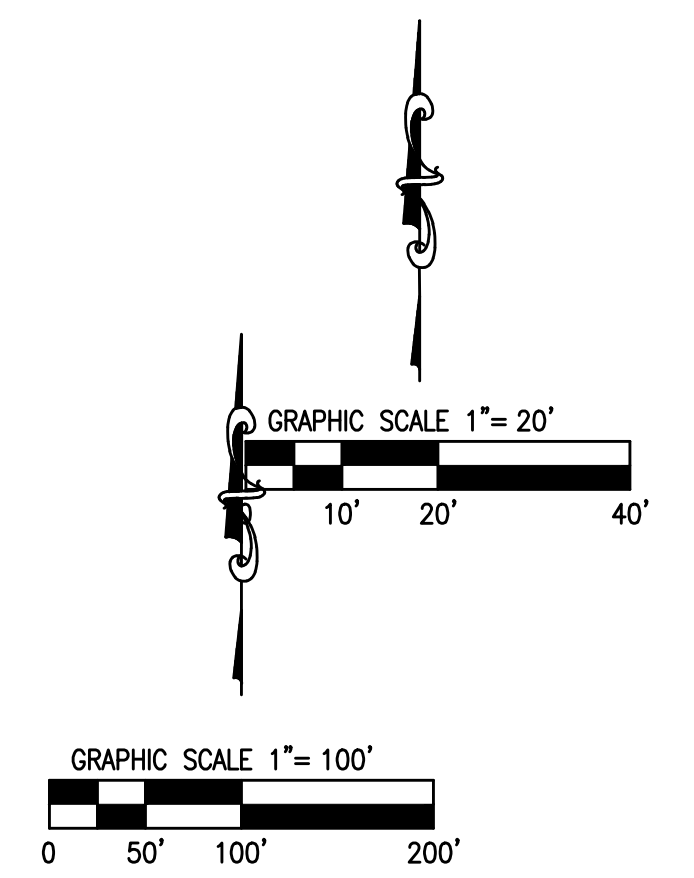
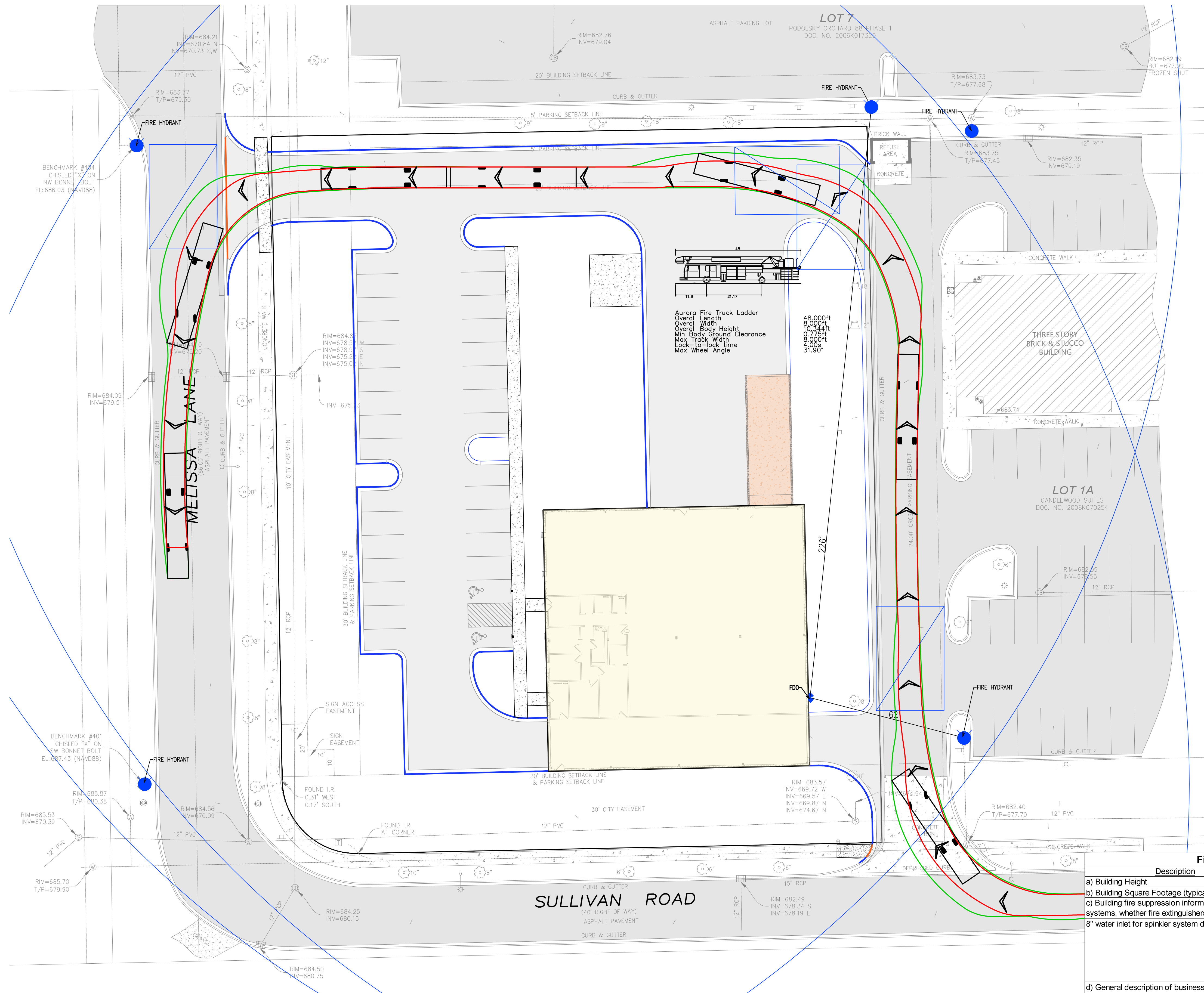

Fire Access Plan Data Table		
Description	Value	Unit
a) Building Height	24.66	feet
b) Building Square Footage (typical)	10,000	square feet
c) Building fire suppression information including any proposed use of sprinkler systems, fire alarm systems, whether fire extinguishers are needed: 8" water inlet for sprinkler system designed to accommodate space of 10,000SF of warehouse.		
d) General description of business to be conducted within each building including: will there be rack storage in the building, will there be storage of combustible materials over twelve feet in height, clearance of sprinkler heads and stored materials (18 inch minimum): This will be a storage distribution building.		

REMARKS	
DATE	
NO.	
<b>ADVANTAGE</b> CONSULTING ENGINEERS 1770 RANDALL ROAD, SUITE A #200, GENEVA, ILLINOIS 60134 630-520-2467 WWW.AVGEN.US	
<b>FIRE ACCESS PLAN</b> <b>BG PRODUCTS OF ILLINOIS</b> 2695 W. SULLIVAN ROAD, AURORA, IL	
<b>CHAPLE DESIGN - BUILD</b> 405 ILLINOIS AVENUE, SUITE 2D ST. CHARLES, IL 60174 P: (630) 523-5590	
JUNE 05, 2025	
JOB: 24-061	
SHEET:	
<b>V1</b>	
1 OF 1	