

ALTA/ACSM LAND TITLE SURVEY

PART OF THE SOUTHEAST QUARTER OF SECTION 35, AND THE SOUTHWEST QUARTER OF SECTION 36, TOWNSHIP 39 NORTH, RANGE 8 EAST OF THE THIRD PRINCIPAL MERIDIAN, BATAVIA TOWNSHIP, KANE COUNTY, ILLINOIS.

LEGAL DESCRIPTION

PARCEL I:

THAT PART OF THE SOUTHEAST QUARTER OF SECTION 35, AND THAT PART OF THE SOUTHWEST QUARTER OF SECTION 36, TOWNSHIP 39 NORTH, RANGE 8 EAST OF THE THIRD PRINCIPAL MERIDIAN BOUNDED AND DESCRIBED AS FOLLOWS: COMMENCING AT THE SOUTHEAST CORNER OF AFORESAID SECTION 35 AND RUNNING WESTERLY ALONG THE SOUTH LINE OF SAID SECTION 19.36 FEET TO A PLACE OF BEGINNING, THENCE NORTHERLY AT A RIGHT ANGLE TO AFORESAID SOUTH LINE OF SECTION 35 A DISTANCE OF 266.01 FEET TO A POINT IN THE SOUTH RIGHT OF WAY OF FEDERAL AID ROAD 131, THENCE EASTERLY ALONG THE AFORESAID RIGHT OF WAY 158.55 FEET, THENCE SOUTHERLY 289.85 FEET TO A POINT IN THE SOUTH LINE OF AFORESAID SECTION 36 A DISTANCE OF 137.39 FEET FROM THE SOUTHWEST CORNER OF AFORESAID SECTION 36, THENCE WESTERLY ALONG THE SOUTH LINE OF AFORESAID SECTION 36 A DISTANCE OF 137.39 FEET TO THE PLACE OF BEGINNING, (EXCEPTING THEREFROM THE FOLLOWING DESCRIBED PARCEL OF LAND COMMENCING AT THE SOUTHEAST CORNER OF SAID SECTION 35; THENCE EAST ALONG SAID SOUTH LINE OF SECTION 36, 13.64 FEET TO AN IRON PIPE FOUND AT THE POINT OF BEGINNING; THENCE NORTHERLY 66.05 FEET TO AN IRON PIPE FOUND; THENCE EASTERLY, 124.00 FEET TO AN IRON PIPE FOUND THENCE SOUTHERLY, 65.82 FEET TO AN IRON PIPE; THENCE WESTERLY ALONG SAID SOUTH LINE OF SECTION 36, 123.69 FEET TO SAID POINT OF BEGINNING) IN KANE COUNTY, ILLINOIS; AND THE EAST 33 FEET, AS MEASURED ALONG THE SOUTH LINE OF THAT PART OF THE SOUTHEAST QUARTER OF SECTION 35, TOWNSHIP 39 NORTH, RANGE 8 EAST OF THE THIRD PRINCIPAL MERIDIAN BOUNDED AND DESCRIBED AS FOLLOWS: COMMENCING AT THE SOUTHEAST CORNER OF SECTION 35 AND RUNNING THENCE WESTERLY ALONG THE SOUTH LINE OF SAID SECTION 19.36 FEET FOR A POINT OF BEGINNING, THENCE NORTHERLY AT RIGHT ANGLES TO THE AFORESAID SOUTH LINE OF SECTION 35, 266.01 FEET TO A POINT IN THE SOUTH RIGHT OF WAY OF FEDERAL AID ROAD 131, THENCE WESTERLY ALONG THE AFORESAID SOUTH RIGHT OF WAY 388.85 FEET TO THE CENTER OF CHURCH ROAD, THENCE SOUTHERLY ALONG THE CENTER OF AFORESAID CHURCH ROAD 208.3 FEET TO THE SOUTH LINE OF AFORESAID SECTION 35, THENCE EASTERLY ALONG SAID SOUTH LINE 384.43 FEET TO THE POINT OF BEGINNING, IN THE TOWNSHIP OF BATAVIA, KANE COUNTY, ILLINOIS.

PARCEL II:

THAT PART OF THE SOUTHWEST QUARTER OF SECTION 36, TOWNSHIP 39 NORTH, RANGE 8 EAST OF THE THIRD PRINCIPAL MERIDIAN, DESCRIBED AS FOLLOWS: COMMENCING AT THE SOUTHWEST CORNER OF SAID QUARTER SECTION; THENCE EAST ALONG THE SOUTH LINE OF SAID QUARTER SECTION, 137.39 FEET; THENCE NORTH AT RIGHT ANGLES TO THE SOUTH LINE OF SAID QUARTER SECTION, 289.85 FEET TO THE SOUTHERLY LINE OF FEDERAL AID ROAD NO. 131 FOR THE POINT OF BEGINNING; THENCE SOUTH ALONG SAID QUARTER SECTION, 312.84 FEET TO THE SOUTHERLY LINE OF SAID FEDERAL AID ROAD NO. 131; THENCE WESTERLY ALONG THE SOUTHERLY LINE OF SAID ROAD, 88.7 FEET TO AN ANGLE IN SAID ROAD; THENCE WESTERLY ALONG THE SOUTHERLY LINE OF SAID ROAD, 58.06 FEET TO THE POINT OF BEGINNING, IN THE TOWNSHIP OF BATAVIA, KANE COUNTY, ILLINOIS.

PARCEL III:

THAT PART OF THE SOUTHWEST QUARTER OF SECTION 36, TOWNSHIP 39 NORTH, RANGE 8 EAST OF THE THIRD PRINCIPAL MERIDIAN, DESCRIBED AS FOLLOWS: COMMENCING AT THE SOUTHWEST CORNER OF SAID QUARTER SECTION, THENCE EAST ALONG THE SOUTH LINE OF SAID QUARTER SECTION, 282.32 FEET, THENCE NORTH AT A RIGHT ANGLE TO THE SOUTH LINE OF SAID QUARTER SECTION 312.84 FEET TO THE SOUTHERLY LINE OF FEDERAL AID ROUTE NO. 131 FOR THE POINT OF BEGINNING, THENCE SOUTH ALONG SAID QUARTER SECTION, 312.84 FEET TO THE SOUTH LINE OF SAID QUARTER SECTION, THENCE EAST ALONG SAID SOUTH LINE 134.52 FEET, THENCE NORTH AT A RIGHT ANGLE TO THE SOUTH LINE OF SAID QUARTER SECTION, 334.74 FEET TO THE SOUTHERLY LINE OF SAID FEDERAL AID ROUTE NO. 131, THENCE WESTERLY ALONG THE SOUTHERLY LINE OF SAID ROAD 136.29 FEET TO THE POINT OF BEGINNING, TOWNSHIP OF BATAVIA, KANE COUNTY, ILLINOIS.

NOTES:

SURVEY PREPARED WITH THE BENEFIT OF FIDELITY NATIONAL TITLE INSURANCE COMPANY TITLE COMMITMENT ORDER NUMBER 15013246, EFFECTIVE DATE, AUGUST 17, 2011.

NO BUILDINGS EXISTING ON THE SURVEYED PROPERTY.

REFERENCE IS MADE TO TERMS AND CONDITIONS OF ANNEXATION AGREEMENT RECORDED DECEMBER 28, 1989 AS DOCUMENT NO. 2017523.

REFERENCE IS MADE TO TERMS AND CONDITIONS OF ANNEXATION AGREEMENT RECORDED FEBRUARY 21, 1990 AS DOCUMENT NO. 90K9227.

REFERENCE IS MADE TO TERMS AND CONDITIONS OF ANNEXATION AGREEMENT RECORDED APRIL 16, 2001 AS DOCUMENT NO. 2001K039711.

REFERENCE IS MADE TO RIGHTS TO THE PUBLIC AND OF THE PEOPLE OF THE STATE OF ILLINOIS UNDER AND BY VIRTUE OF A DEDICATION FOR HIGHWAY PURPOSES DATED APRIL 11, 1940 AND RECORDED JUNE 3, 1940 AS DOCUMENT 453986. THIS RIGHT OF WAY IS NOT A PART OF THE BOUNDARY OF THIS SURVEY, BUT APPEARS TO COVER AREAS OF CHURCH ROAD, WEST OF SITE.

SURVEYOR'S CERTIFICATE

STATE OF ILLINOIS)
 COUNTY OF DUPAGE) SS

TO: FIRST COMMUNITY BANK OF JOLIET
 FIDELITY NATIONAL TITLE INSURANCE COMPANY

THIS IS TO CERTIFY THAT THIS MAP OR PLAT AND THE SURVEY ON WHICH IT IS BASED WERE MADE IN ACCORDANCE WITH 2011 MINIMUM STANDARD DETAIL REQUIREMENTS FOR ALTA/ACSM LAND TITLE SURVEYS, JOINTLY ESTABLISHED AND ADOPTED BY ALTA AND NSPS, AND INCLUDES ITEMS 1, 4, 8 AND 11A OF TABLE A THEREOF. THE FIELD WORK WAS COMPLETED ON AUGUST 22, 2011.

DATE OF PLAT OR MAP: SEPTEMBER 6, 2011

BY: *Mark S. Stimac*
 ILLINOIS PROFESSIONAL LAND SURVEYOR NO. 35-2587
 MY LICENSE EXPIRES/RENEWS 11-30-2012



INTECH CONSULTANTS, INC.
 ENGINEERS / SURVEYORS
 1989 UNIVERSITY LANE, SUITE D LISLE, ILLINOIS
 TEL: (630) 964-5656 FAX: (630) 964-5052
 E-MAIL: CAD@INTECHCONSULTANTS.COM
 ILLINOIS REGISTRATION NO. 184-001040

PREPARED: 9-6-11

SHEET No. 1 of 1 JOB No.: 6509

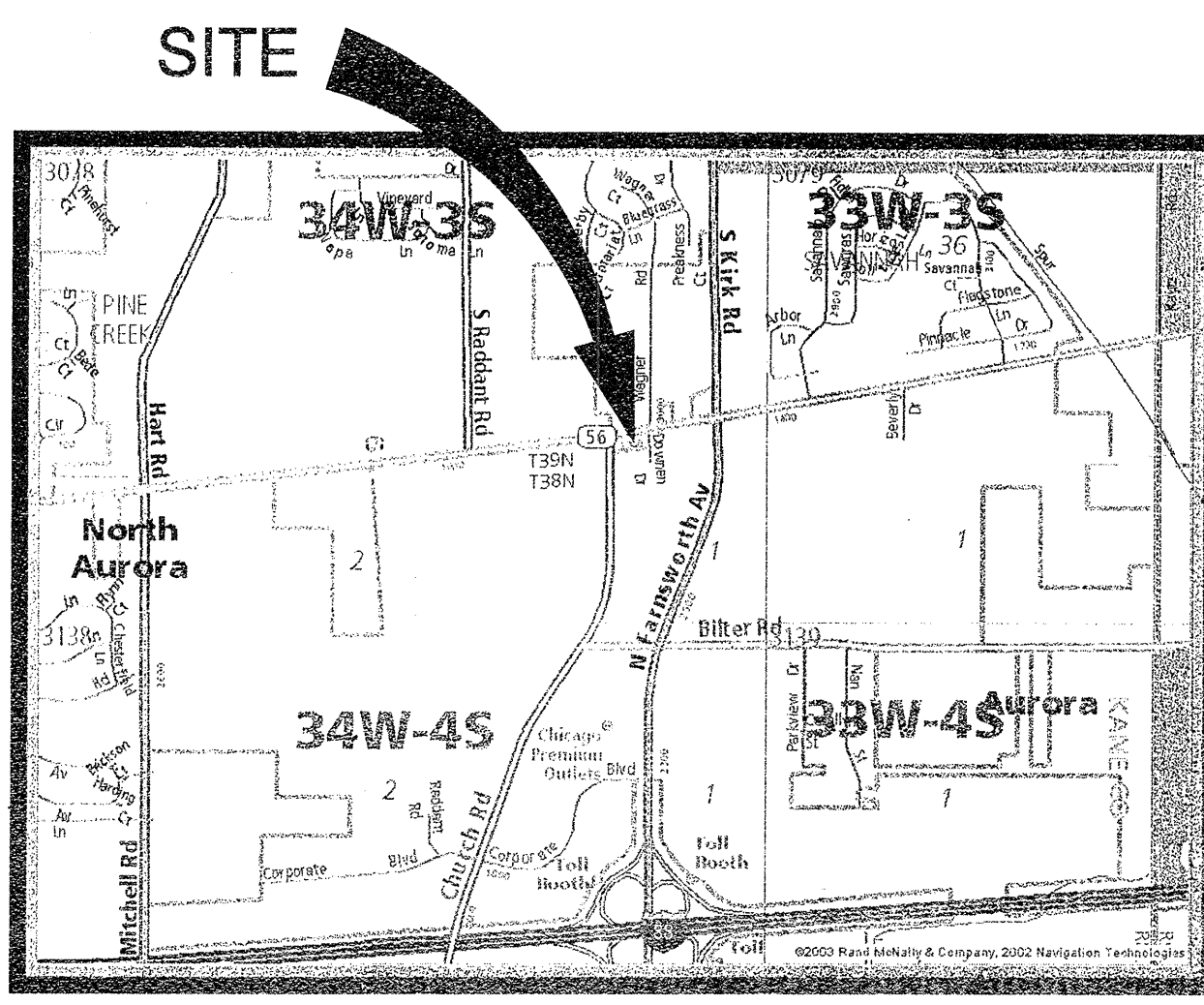

LOCATION MAP
 NOT TO SCALE

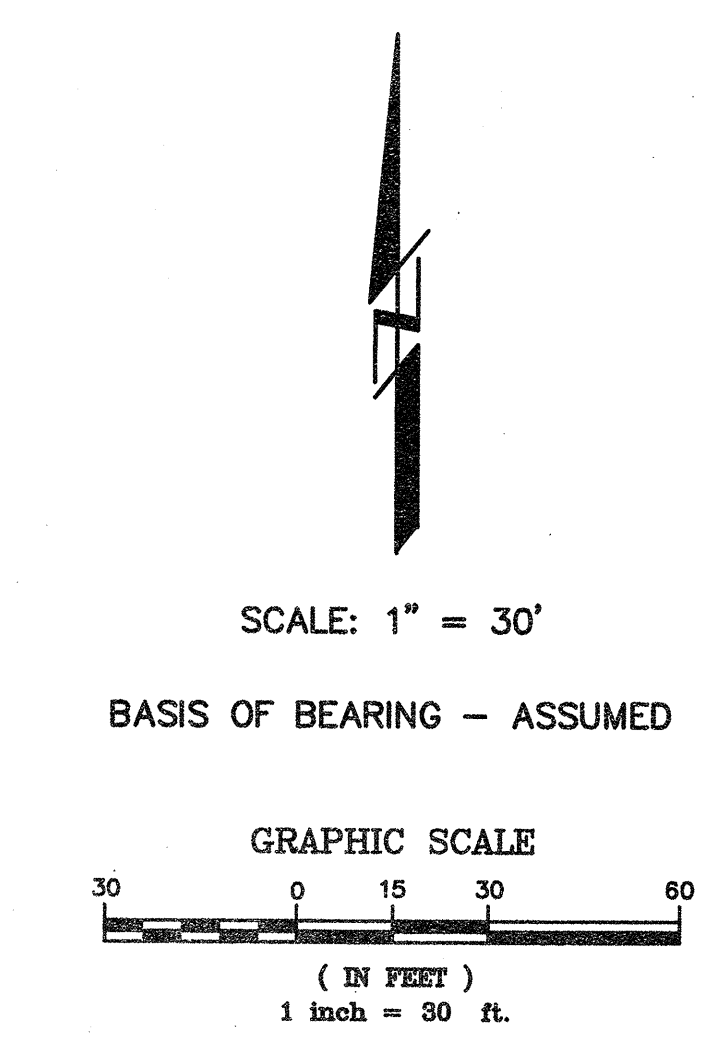

| LEGEND | |
|----------|-----------------------|
| EXISTING | |
| — W — | WATERMAIN |
| — OH — | OVERHEAD WIRES |
| — G — | GAS LINE |
| — F — | FENCE |
| ⊗ | VALVE IN VAULT |
| ⊙ | LIGHT POLE (MAST ARM) |
| ⊕ | POWER POLE |
| ⊖ | GUY WIRE |
| ⊠ | PEDESTAL |
| ⊡ | SIGN |
| — | CURB & GUTTER |

SITE AREA: 131,402 SQ.FT. = 3.0166 ACRES

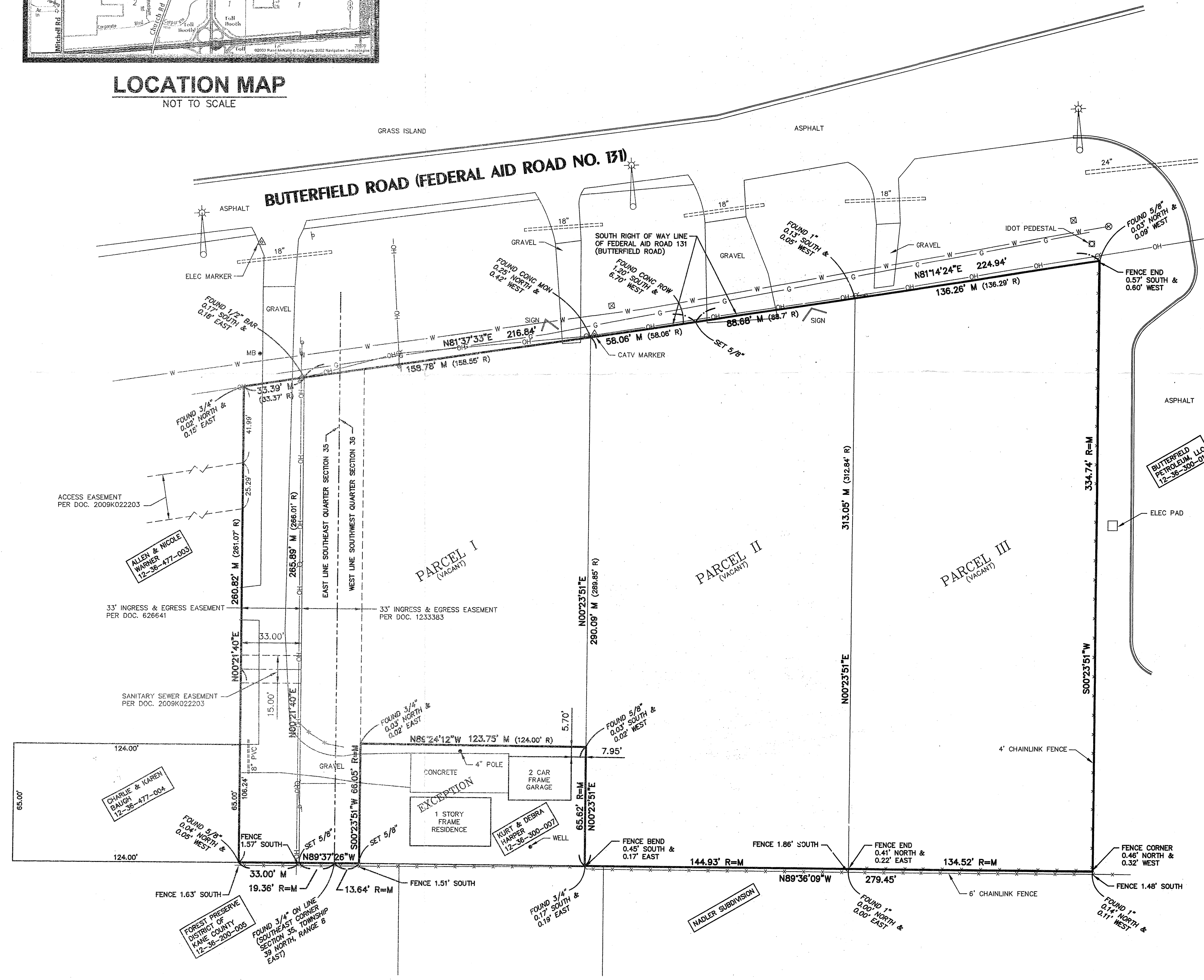

CAD Projects\SURVEY\600016509\dwg\6509 ALTA.dwg, ALTA, 9/9/2011 8:28:55 AM, SLP

ALTA/ACSM LAND TITLE SURVEY