

**NOT FOR
CONSTRUCTION**

FOR REVIEW ONLY
Not for regulatory approval, permit or construction.

The information on this document is preliminary or incomplete, not for construction, recording purposes, or implementation.

ISSUANCE

NO	DATE	DESCRIPTION
07/25/2024	07/25/2024	ISSUE FOR REVIEW

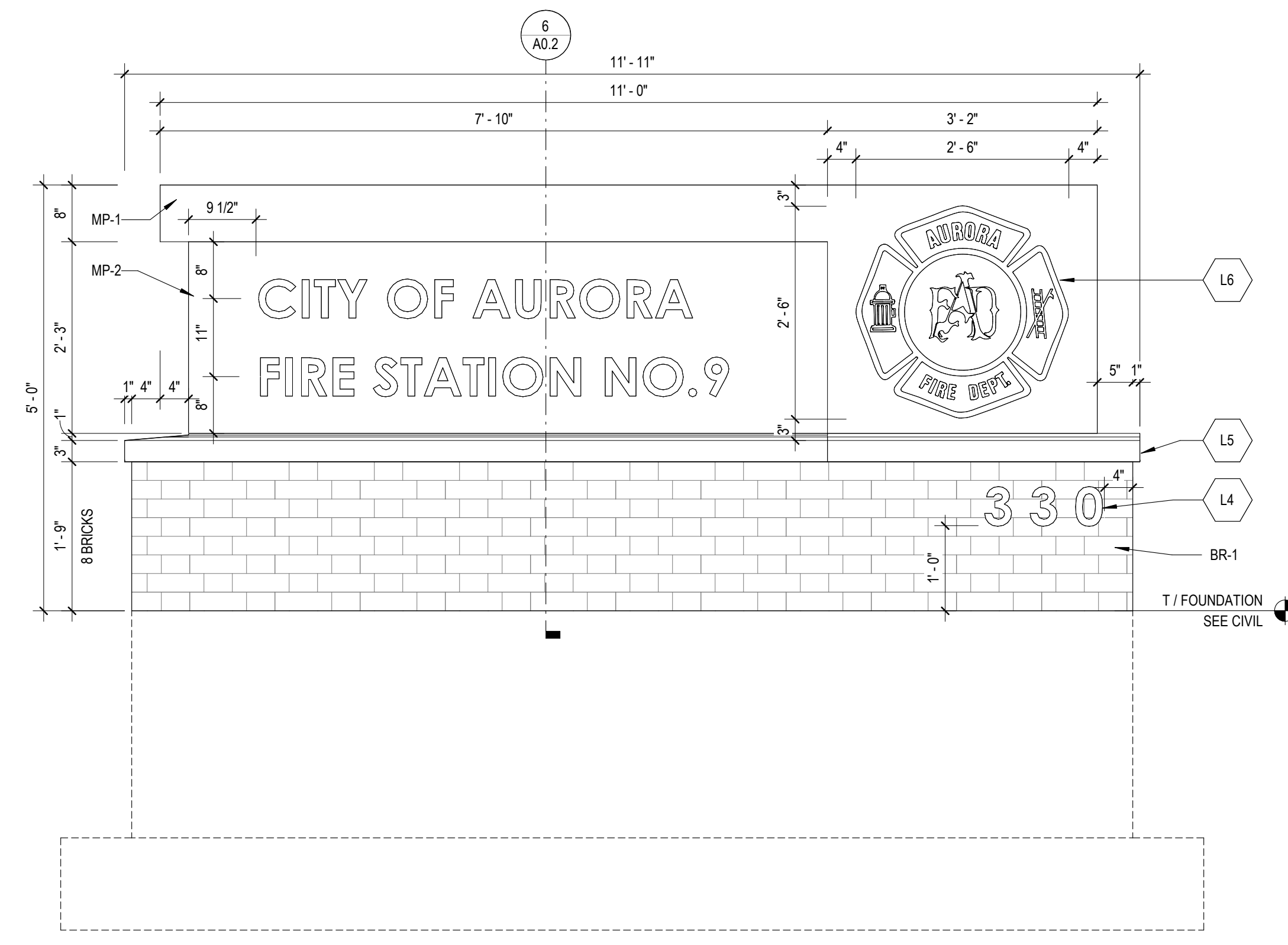

5 ELEVATION - MONUMENT SIGN
3/4" = 1'-0"

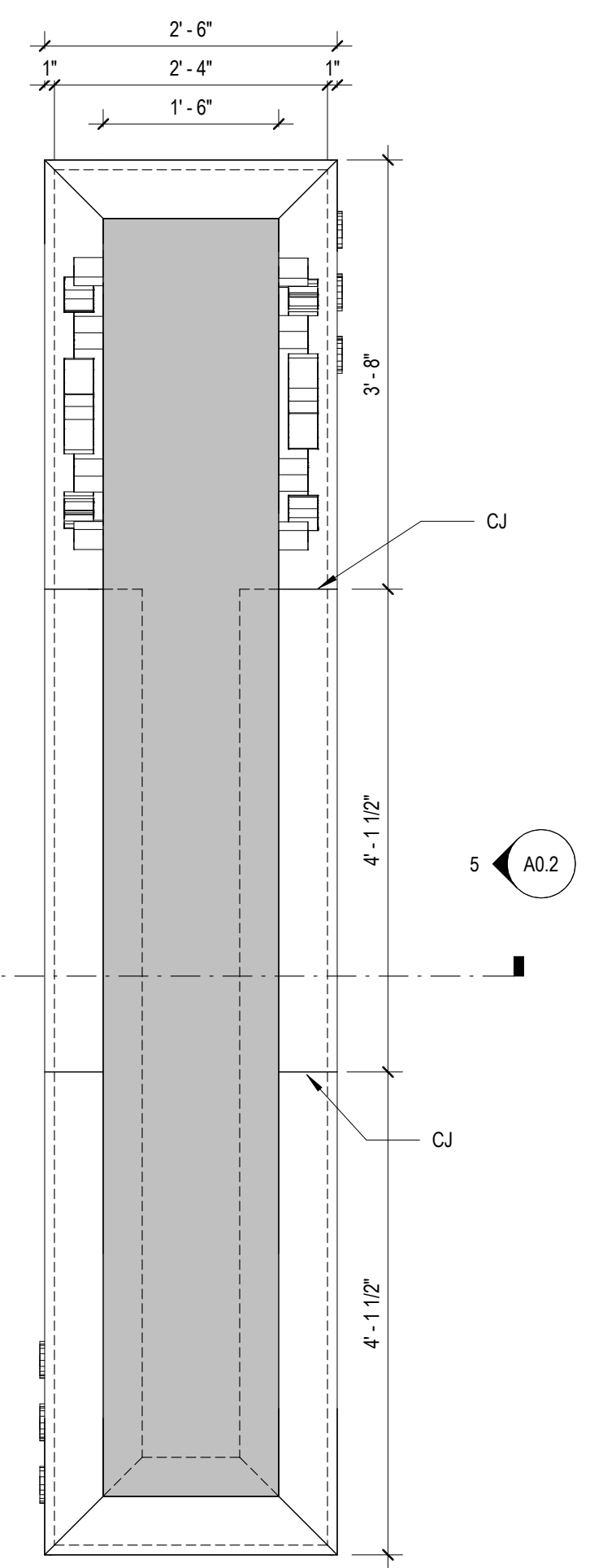

4 PLAN - MONUMENT SIGN
3/4" = 1'-0"

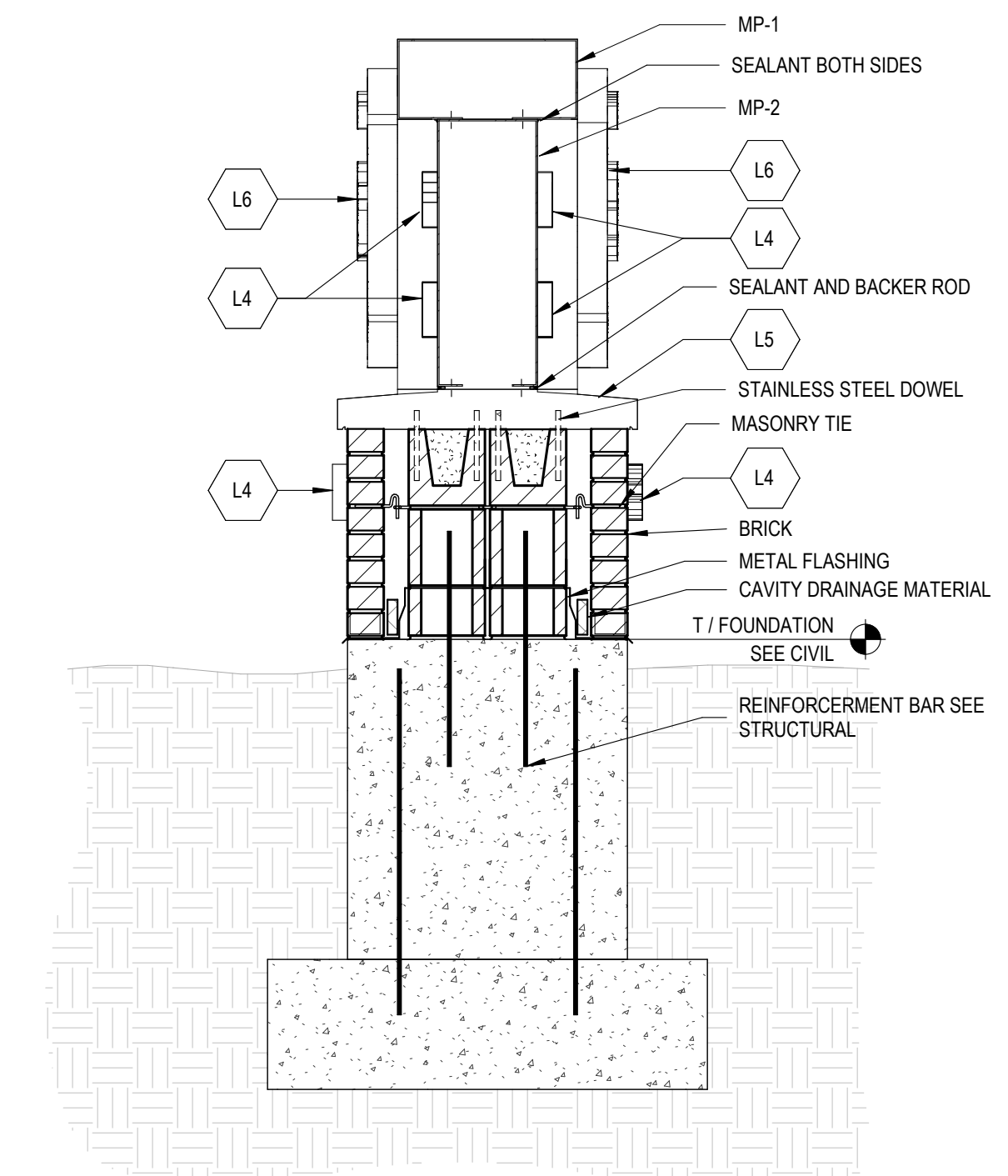

6 SECTION - MONUMENT SIGN
3/4" = 1'-0"

GENERAL SITE PLAN NOTES

- 1. REFER TO G-SERIES SHEETS FOR TYPICAL ABBREVIATIONS, SYMBOLS & TAGS.
- 2. REFER TO CIVIL AND LANDSCAPE DRAWINGS FOR ADDITIONAL INFORMATION.
- 3. EXPOSED FERROUS METALS ARE TO BE PAINTED, U.N.O.
- 4. PROVIDE GALVANIC SEPARATION BETWEEN DIFFERENT METAL TYPES, TYP.
- 5. NOTE ANY DISCREPANCIES BETWEEN CIVIL AND ARCHITECTURAL DRAWINGS WITH REGARDS TO SCORING PATTERNS AND CONTROL JOINTS IN PAVING AND CONCRETE FLATWORK AND NOTIFY ARCHITECT PRIOR TO PROCEEDING.
- 6. COORDINATE SITE LIGHTING WITH ELECTRICAL DRAWINGS.
- 7. SEE LANDSCAPE DRAWINGS FOR TREE LOCATIONS.
- 8. FOR DETAILED CIVIL NOTES, REFER TO CIVIL DRAWINGS.

SITE PLAN LEGEND

- PROPERTY LINE
- - - SETBACK LINE
- EASEMENT LINE
- ROOF OVERHANG LINE
- × × × × FENCE LINE
- [Stippled Pattern] INDICATES CONCRETE PAVEMENT, SEE CIVIL SERIES
- [Diagonal Hatching] INDICATES BUILDING FOOTPRINT
- [Dotted Pattern] INDICATES CONCRETE SIDEWALK, SEE CIVIL SERIES
- [Solid Grey] INDICATES SNOW MELT SYSTEM, SEE CIVIL AND MECHANICAL SERIES
- [Light Grey] INDICATES NEW ASPHALT PAVEMENT.

EXTERIOR MATERIALS LEGEND

EXTERIOR PAINT

PT-1X EXTERIOR PAINT TO BE:
MFR: TO BE SELECTED BY ARCHITECT
COLOR: TO BE SELECTED BY ARCHITECT
LOCATIONS: T / CANOPY, T / MASONRY

PT-2X EXTERIOR PAINT TO BE:
MFR: TO BE SELECTED BY ARCHITECT
COLOR: TO BE SELECTED BY ARCHITECT
LOCATIONS: T / MASONRY

MASONRY VENEER BRICK (DESIGN BASIS)

BR-1 FACE BRICK
MFR: GLEN GERY, SIOUX CITY BRICK
SIZE: NORMAN (3 5/8" W x 2 1/4" H x 11 5/8" L)
BOND PATTERN: FLEMISH BOND
COLOR: BEIGE GRAY SMOOTH
USE: AS BLDG. BRICK VENEER AS INDICATED ON ELEVATIONS

BR-2 FACE BRICK
MFR: GLEN GERY, SIOUX CITY BRICK
SIZE: NORMAN (3 5/8" W x 2 1/4" H x 11 5/8" L)
BOND PATTERN: FLEMISH BOND WITH EVERY 4TH COURSE 1" PROJECTING SOLID BRICK HEADER. SEE DETAIL FOR PATTERN
COLOR: BEIGE GRAY SMOOTH
USE: AS BLDG. BRICK VENEER AS INDICATED ON ELEVATIONS

BR-3 FACE BRICK
MFR: GLEN GERY, SIOUX CITY BRICK
SIZE: MODULAR (3 5/8" W x 2 1/4" H x 7 5/8" L)
BOND PATTERN: SOLDIER COURSE
COLOR: BEIGE GRAY SMOOTH
USE: AS BLDG. BRICK VENEER AT DOOR AND STOREFRONT LINTELS, UNO. SEE ELEVATIONS

FLEMISH BOND PATTERN

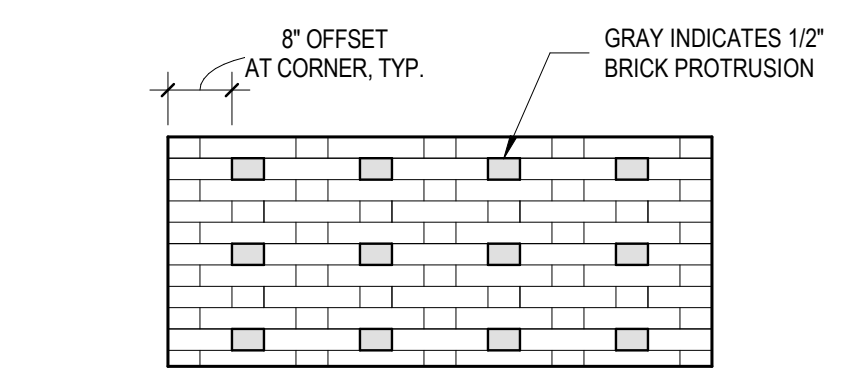

DRY SEAL FORMED METAL WALL PANEL (DESIGN BASIS)

MP-1 DRY SEAL COMPOSITE METAL PANEL SYSTEM
MFR: REYNOLDBOND
PRODUCT: 4MM FR
PAINT SYSTEM: DURAGLOSS 6000
PAINT FINISH: ZINC CHARCOAL
SIZES: 8" PANEL (LENGTH) X 2" PANEL (WIDTH)

MP-2 DRY SEAL COMPOSITE METAL PANEL SYSTEM
MFR: REYNOLDBOND
PRODUCT: 4MM FR
PAINT SYSTEM: DURAGLOSS 6000
PAINT FINISH: ZINC PATINA
SIZES: 8" PANEL (LENGTH) X 2" PANEL (WIDTH)

ROOF COPING

RC-1 METAL COPING TO BE:
MFR: PER DETAILS, INTEGRAL WITH FASCIA / PARAPET
SIZE: PER DETAILS, INTEGRAL WITH FASCIA / PARAPET (SLOPE TOP)
TYPE: PER DETAILS, INTEGRAL WITH FASCIA / PARAPET (SLOPE TOP)
COLOR: SELECTED BY ARCHITECT FROM MANUFACTURERS FULL RANGE

ROOF SCREEN

RS-1 ROOF SCREEN TO BE:
MFR: SELECTED BY ARCHITECT FROM MANUFACTURERS FULL RANGE
STYLE: SELECTED BY ARCHITECT FROM MANUFACTURERS FULL RANGE
SIZE: SELECTED BY ARCHITECT FROM MANUFACTURERS FULL RANGE
TYPE: SELECTED BY ARCHITECT FROM MANUFACTURERS FULL RANGE
COLOR: SELECTED BY ARCHITECT FROM MANUFACTURERS FULL RANGE

STOREFRONT / CURTAINWALL

SF-1 STOREFRONT BASIS OF DESIGN TO BE:
MFR: KAWNEER
COLOR: PEWTER
SIZE: 2" X 8"
NOTE: REFER TO A6 SERIES WINDOW TYPES SHEET FOR MORE INFO

CW-1 CURTAINWALL BASIS OF DESIGN TO BE:
MFR: KAWNEER
COLOR: PEWTER
SIZE: 2" X 8"
NOTE: REFER TO A6 SERIES WINDOW TYPES SHEET FOR MORE INFO

EXTERIOR ELEVATIONS KEYED NOTES

TAG	DESCRIPTION
L1	PIPE BOLLARD
L4	DIMENSIONAL LETTER SIGNAGE, 1-1/2" DEEP EXTRUDED ALUMINUM NUMBERING, 5 1/2" HIGH. FONT: CENTURY GOTHIC, ANODIZED BLACK FINISH, MOUNTED ON STAND-OFFS. PROVIDE INDIVIDUAL LED BACKLIGHTING FOR EACH NUMBER, TYP. DIMENSIONAL LETTER SIGNAGE, 1-1/2" DEEP EXTRUDED ALUMINUM NUMBERING, 8" HIGH. FONT: CENTURY GOTHIC, ANODIZED BLACK FINISH, MOUNTED ON STAND-OFFS. PROVIDE INDIVIDUAL LED BACKLIGHTING FOR EACH LETTER, TYP.
L5	CAST STONE CAP TO PITCH AWAY FROM SIGN ENCLOSURE AS SHOWN. PROVIDE INTEGRAL DRIP EDGE, TYP.
L6	ANODIZED ALUMINUM SIGNAGE, 1" DEEP, STUD MOUNTED TO FACE OF METAL PANEL WITH BACKLIT LED LIGHTING. REFER TO ELECTRICAL SERIES TO SPECIFICATIONS AND ELECTRICAL SERIES FOR ADDITIONAL INFORMATION.

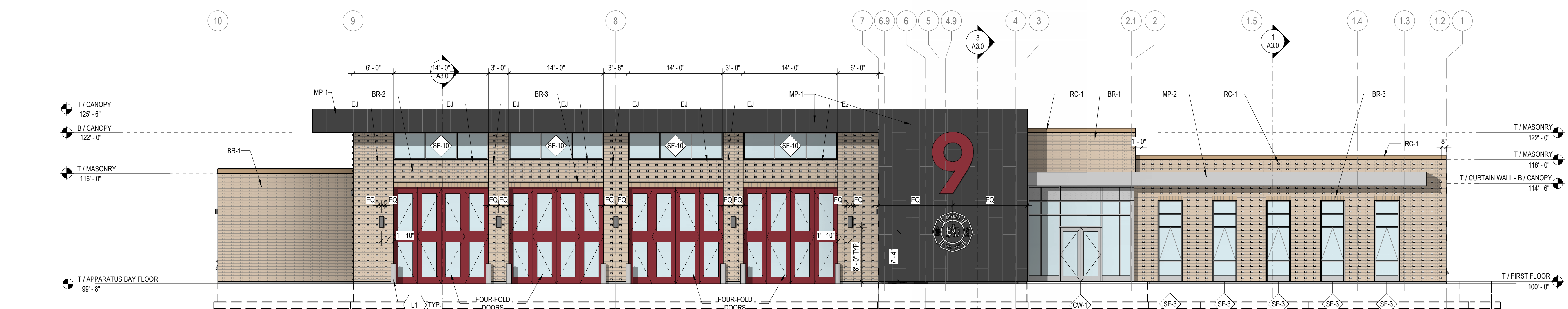

4 EXTERIOR ELEVATION - EAST
1/8" = 1'-0"

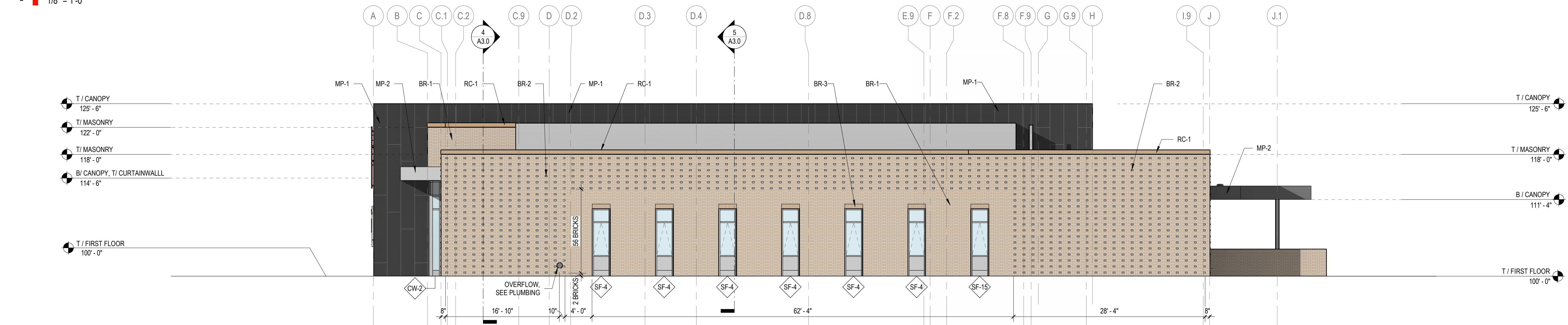

3 EXTERIOR ELEVATION - NORTH
1/8" = 1'-0"

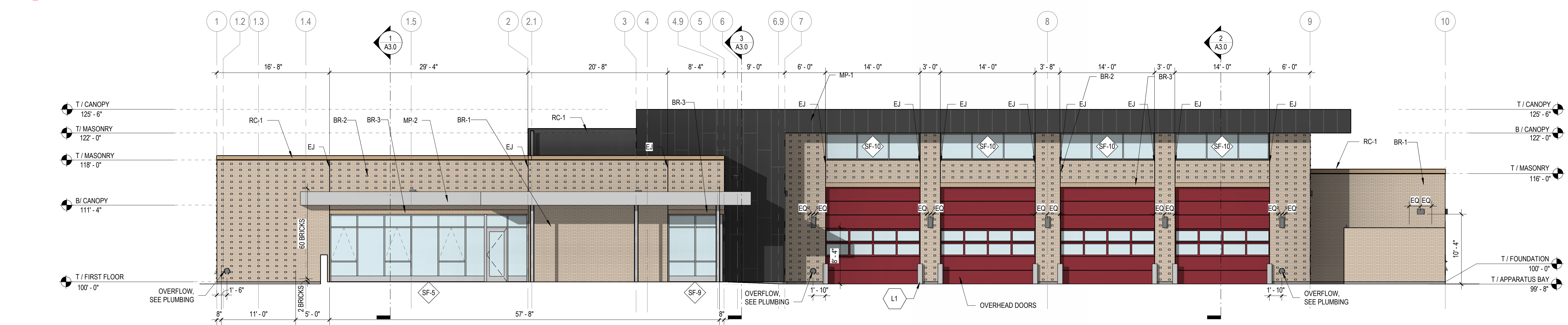

2 EXTERIOR ELEVATION - WEST
1/8" = 1'-0"

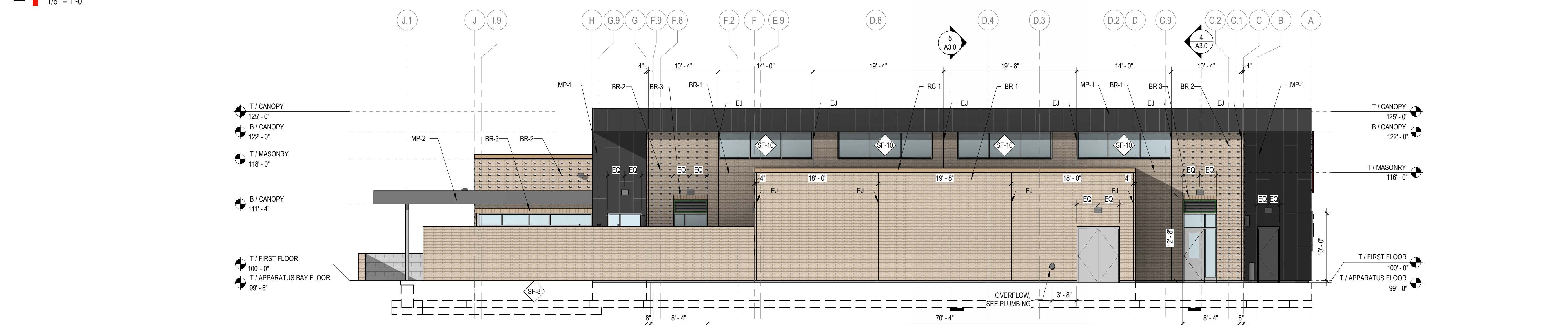

1 EXTERIOR ELEVATION - SOUTH
1/8" = 1'-0"