

ALTA/ACSM LAND TITLE SURVEY

ST. PAUL'S LUTHERAN CHURCH SUBDIVISION OF PART OF THE NORTH HALF OF SECTION 19, TOWNSHIP 38 NORTH, RANGE 8 EAST OF THE THIRD PRINCIPAL MERIDIAN, ACCORDING TO THE PLAT THEREOF RECORDED NOVEMBER 9, 1993 AS DOCUMENT NO. 93K88915, IN KANE COUNTY, ILLINOIS.

LEGEND

—	Boundary of property surveyed
•	Indicates found survey marker
○	Indicates set open end pipe
—x—x—	Indicates fence line
C.E.	Indicates city easement
U.E.	Indicates utility easement
⊥	Indicates light pole
⊕	Indicates manhole
⊕	Indicates electric handhole
⊕	Indicates cable tv pedestal
⊕	Indicates telephone pedestal
⊕	Indicates electric transformer
⊕	Indicates sign
⊕	Indicates catch basin
⊕	Indicates sanitary manhole
⊕	Indicates B-Box
⊕	Indicates cleanout
⊕	Indicates electric meter
⊕	Indicates gas meter
⊕	Indicates patio light
⊕	Indicates fire hydrant
⊕	Indicates valve vault
⊕	Indicates water manhole

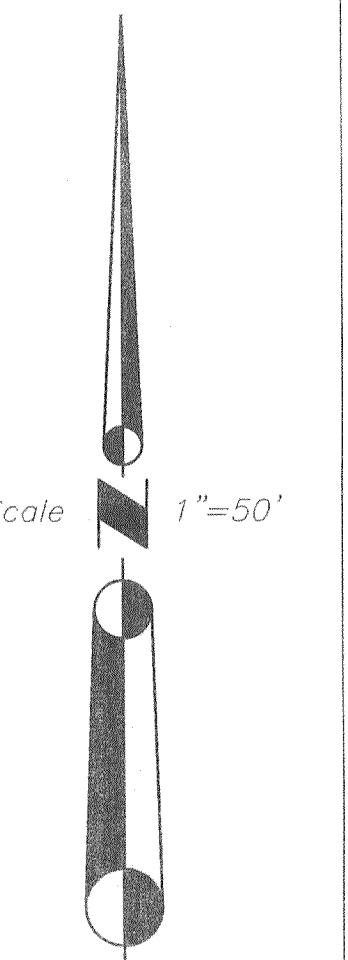

LOT 4
PARK/DETENTION AREA

Total Area = 10.55 Acres
Address of property: 85 Constitution Drive
Aurora, Illinois.

Parking Spaces: 174 Regular Spaces
7 Handicap Spaces
P.I.N. 15-19-176-037

LOT 1
WEST REIMERS SUBDIVISION

LOT 1
ST. PAULS LUTHERAN CHURCH SUBDIVISION

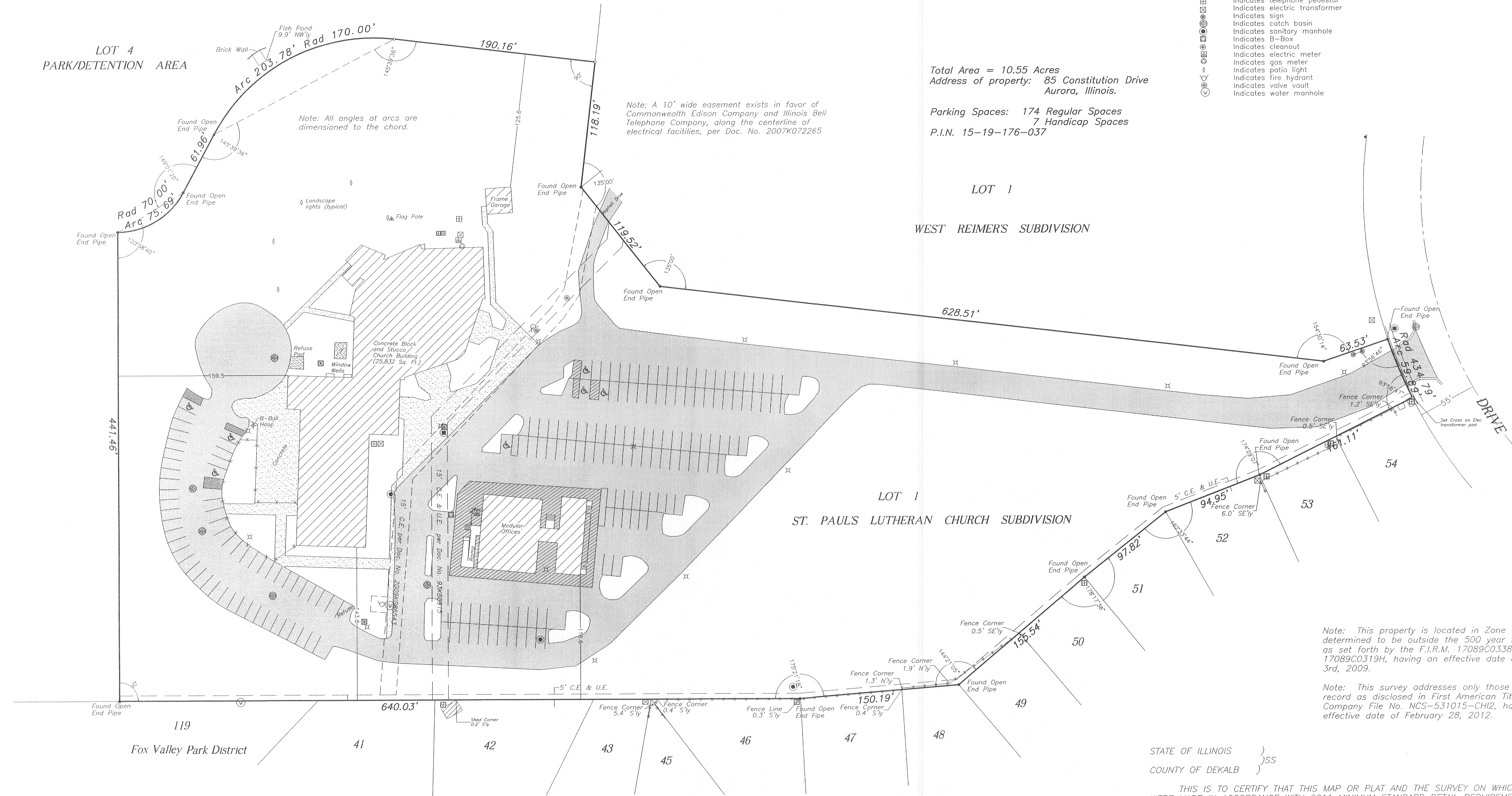

Note: This property is located in Zone "X", area determined to be outside the 500 year flood plain, as set forth by the F.I.R.M. 17089C0338H and 17089C0319H, having an effective date of August 3rd, 2009.

Note: This survey addresses only those matters of record as disclosed in First American Title Insurance Company File No. NCS-531015-CH2, having an effective date of February 28, 2012.

STATE OF ILLINOIS }
COUNTY OF DEKALB }SS

THIS IS TO CERTIFY THAT THIS MAP OR PLAT AND THE SURVEY ON WHICH IT IS BASED WERE MADE IN ACCORDANCE WITH 2011 MINIMUM STANDARD DETAIL REQUIREMENTS FOR ALTA/ACSM LAND TITLE SURVEYS, JOINTLY ESTABLISHED AND ADOPTED BY ALTA AND NSPS, AND INCLUDES ITEMS 1, 2, 3, 4, 7(B) (1), 8, 9 and 11(A) OF TABLE A THEREOF. FIELD WORK COMPLETED ON THIS 7TH DAY OF AUGUST, 2012. DATED AT DEKALB, ILLINOIS THIS 16TH DAY OF AUGUST, 2012.

SHAWN R. VAN KAMPEN
ILLINOIS PROFESSIONAL LAND SURVEYOR NO. 2710
LICENSE EXPIRATION DATE: NOVEMBER 30TH, 2012

Prepared by:
William E. Hanna Surveyors
License No. 1842807
508 Pine Street
DeKalb, Illinois 60115
(815) 756-2189
Fax 748-2532
info@hannasurveyors.com