

DSC NORTH - SECOND FLOOR
 77 S. BROADWAY
 AURORA, IL 60505

MGH ENGINEERING
MGH Consulting Engineers, LLC
 LICENSE NO. 184.007292-0002
 408 S. Highland Ave. Arlington Heights, IL 60005
 mghengineering.com Phone: 773.314.1919

ELECTRICAL SYMBOL LIST GENERAL NOTES & DETAILS

ISSUED:
 3-19-19 ISSUED FOR REVIEW
 4-8-19 ISSUED FOR PERMIT
 4-23-19 ISSUED FOR PERMIT COMMENTS

E001

GENERAL NOTES

- THIS INSTALLATION SHALL BE IN COMPLIANCE WITH THE CITY OF AURORA, IL BUILDING CODES OF ORDINANCES, LOCAL AMENDMENTS AND NATIONAL CODES INCLUDING BUT NOT LIMITED TO: 2015IBC, 2014NEC, 2015IECC, AND NFPA72.
- BEFORE COMMENCING WORK THE CONTRACTOR SHALL VISIT THE JOB SITE AND FULLY INFORM HIMSELF OR HERSELF OF ALL CONDITIONS THAT AFFECT THE WORK. EXAMINE THE DRAWINGS AND SPECIFICATIONS SHEET, AND SUBMIT ANY QUESTIONS IN WRITING TO THE ARCHITECT AND ENGINEER.
- ALL ELECTRICAL DRAWINGS ARE TO BE READ IN CONJUNCTION WITH THE PROJECT SPECIFICATION SHEET AND ALL OTHER DRAWINGS RELATED TO THE PERFORMANCE OF THE WORK.
- THE CONTRACTOR RESPONSIBLE FOR THE EXECUTION OF THIS WORK SHALL BECOME THOROUGHLY FAMILIAR WITH THE PROJECT BEFORE COMMENCING ANY WORK. THE PROJECT DRAWINGS FORM THE BASIS OF THIS CONTRACT REQUIREMENTS AND INCLUDE THE TYPE AND GRADE OF MATERIALS TO BE INSTALLED, EQUIPMENT TO BE FURNISHED, THE MANNER BY WHICH TO BE INSTALLED AND WHERE TO BE LOCATED. IN THE EVENT OF A CONFLICT BETWEEN THE PROJECT SPECIFICATIONS AND DRAWINGS & THE MOST STRICT METHOD GOVERN UNLESS THE ARCHITECT/ENGINEER DIRECTS OTHERWISE.
- THE ELECTRICAL CONTRACTOR SHALL CHECK CAREFULLY ALL CONSTRUCTION DRAWINGS THAT ARE PART OF THIS PROJECT TO ENSURE THAT NO FIXTURE, OUTLET, ALARM STATION, CONTROL DEVICE, POWER WIRING DEVICE, ETC., IS OMITTED. HE/SHE SHALL CONSULT ALL TRADES FURNISHING EQUIPMENT AND OBTAIN FROM THEM ALL DATA. IN SOME CASES EQUIPMENT, FIXTURES AND DEVICES ARE SHOWN ONLY. ASCERTAIN AND PROVIDE THE WIRING AND CONTROL STATIONS REQUIRED FOR THE PROPER FUNCTION OF BUILDING EQUIPMENT. NO EXTRA CHARGES SHALL BE ACCEPTED BY OWNER AFTER BIDDING FOR SUCH EQUIPMENT AND LABOR.
- EQUIPMENT LABELS AND INSTRUCTIONS REGARDING THE APPLICATION AND INSTALLATION OF THE LISTED EQUIPMENT SHALL BE FOLLOWED TO INSURE THAT THE EQUIPMENT IS BEING INSTALLED IN ACCORDANCE WITH THE MANUFACTURER'S LISTING INSTRUCTIONS. THE TEMPERATURE RATING OF THE EQUIPMENT TERMINATIONS MUST BE CAREFULLY CORRELATED WITH THE CONDUCTOR AMPACITY TO PREVENT OVERHEATING AND PREMATURE FAILURE.
- INSTALL ELECTRICAL DEVICES AS INDICATED IN THIS SET OF DRAWINGS. ADJUST FINAL DEVICE LOCATIONS AS REQUIRED TO ACCOMMODATE WORK. COORDINATE WITH ALL TRADES INVOLVED AND WITH ARCHITECTURAL CASEWORK AND ELEVATIONS DRAWINGS. NOTIFY THE ENGINEER AND/OR THE ARCHITECT IF ANY CONFLICTS ARE FOUND PRIOR TO BIDDING PROJECT. INSTALL CONDUIT AND BOXES TO CLEAR EMBEDDED DUCTS, OPENINGS AND OTHER STRUCTURAL FEATURES.
- ALL LIGHTING FIXTURES ARE TO BE LOCATED AS REQUIRED ON THE JOB TO CLEAR DUCTS, PIPING, EQUIPMENT, AND/OR MECHANICAL UNITS.
- CONDUIT RUNS SHOWN ON DRAWINGS ARE DIAGRAMMATIC. ALL CONDUITS SHALL RUN CONCEALED, EXCEPT IN EQUIPMENT ROOMS AND WHERE APPROVED BY THE ARCHITECT.
- FURNISH AND INSTALL EQUIPMENT DISCONNECT SWITCHES IN STRICT COMPLIANCE WITH CODE REQUIREMENTS.
- ADJACENT POWER AND DATA DEVICES SHALL BE SPACED NO MORE THAN 4" APART. PROVIDE JUNCTION BOX MOUNTING BRACKET BETWEEN STUDS AS NEEDED. SEE DETAIL THIS SHEET FOR ADDITIONAL INFORMATION.
- ALL RECEPTACLES, VOICE AND DATA OUTLETS SHALL BE MOUNTED PER MOUNTING HEIGHT LEGEND, UNLESS OTHERWISE NOTED. SEE DETAIL THIS SHEET FOR ADDITIONAL INFORMATION. ALL DEVICES SHALL BE NEW. REFER TO ARCHITECTURAL CASEWORK DRAWINGS AND ARCHITECTURAL ELEVATIONS FOR EXACT DEVICES MOUNTING HEIGHTS.
- REFER TO FIRE ALARM SHEET IN THIS SET OF DRAWINGS FOR FIRE ALARM SYSTEM INFORMATION.
- DETERMINE, IN ADVANCE OF PURCHASE, THAT ALL ELECTRICAL MATERIALS AND EQUIPMENT TO BE INSTALLED SHALL FIT INTO THE ROOM OR SPACE ALLOCATED, AS INDICATED ON THE DRAWINGS, ALLOWING SUFFICIENT CLEARANCE FOR THE SAFE SERVICE AND/OR MAINTENANCE OF RELATED EQUIPMENT, INCLUDING THAT OF OTHER TRADES.
- ALL CIRCUITS SHALL HAVE AN EQUIPMENT GROUNDING CONDUCTOR INSTALLED. COLOR OF GROUNDING CONDUCTOR SHALL BE GREEN. SIZE OF GROUNDING CONDUCTOR SHALL BE AS REQUIRED PER NEC ARTICLE 250.122.
- ALL BRANCH CIRCUITS SHALL HAVE A DEDICATED NEUTRAL CONDUCTOR INSTALLED UNLESS OTHERWISE INDICATED. COLOR OF NEUTRAL CONDUCTOR SHALL BE WHITE.
- ALL CONDUCTOR SHALL BE MADE OF COPPER. MINIMUM WIRE SIZE SHALL BE #12AWG UNLESS OTHERWISE INDICATED. UTILIZE SOLID CONDUCTORS FOR WIRE GAGES UP TO #12AWG AND STRANDED CONDUCTOR FOR GAGES #10AWG AND LARGER.
- SPECIAL RECEPTACLES PLUG CONFIGURATION REQUIREMENTS SHALL BE COORDINATED WITH EQUIPMENT PLUG REQUIREMENTS PRIOR TO INSTALLATION.
- ALL FEEDER AND BRANCH CIRCUIT WIRING INSTALLED INDOORS SHALL USE THHN INSULATION (90F). ALL WIRING INSTALLED OUTDOORS SHALL USE THWN INSULATION (75F). REFER TO SPECIFICATION SHEET FOR COLOR CODED REQUIREMENTS.
- ALL POWER WIRING SHALL BE INSTALLED IN A DEDICATED RACEWAY SYSTEM. MINIMUM RACEWAY SIZE SHALL BE 3/4" UNLESS OTHERWISE INDICATED. CONTRACTOR SHALL SIZE ALL CONDUITS SO AS TO NOT EXCEED 40% OF CONDUIT FILLING CAPACITY. WHEN MORE THAN THREE CURRENT CARRYING CONDUCTORS ARE INSTALLED IN THE SAME CONDUIT AND AMBIENT TEMPERATURES ADJUSTMENT FACTORS PER ELECTRICAL CODE TABLES 310.15(B)(2)(A), 310.15(B)(3)(A) SHALL BE APPLIED.
- ALL CIRCUITS SERVING EMERGENCY EXIT SIGNS, NIGHT LIGHTS AND EXTERIOR LIGHTS SHALL UTILIZE #10 WIRE TO MINIMIZED VOLTAGE DROP UNLESS OTHERWISE INDICATED.
- ALL BREAKERS SERVING FIRE ALARM EQUIPMENT AND EXIT SIGNS SHALL HAVE LOCK-OUT DEVICE INSTALLED UNLESS OTHERWISE INDICATED.
- DISTRIBUTION PANELS AND BRANCH CIRCUIT PANELBOARDS, SHALL BE LABELED WITH PANEL NAME AND ALSO HAVE A PANEL DIRECTORY INSTALLED. UTILIZE TYPE WRITER AS A MINIMUM FOR COMPLIANCE. HAND WRITTEN CARD DIRECTORIES ARE NOT ACCEPTABLE.
- PANELBOARDS, DISCONNECT SWITCHES, ETC. SHALL BE LABEL WITH A READILY VISIBLE LABEL PER NFPA 70E, STANDARD FOR SAFETY IN THE WORKPLACE, LABEL SHALL BE CLEARLY VISIBLE TO PERSONNEL AND SHALL READ "CAUTION ARC FLASH HAZARD" ALSO LABELS SHALL INDICATE THE AVAILABLE SHORT CIRCUIT CURRENT AT EQUIPMENT, PPE, VOLTAGE, PHASES, SIZE AND COLOR OF TEXT SHALL BE PER STANDARD.
- ALL FINAL CONNECTIONS TO MOTORS AND VIBRATING EQUIPMENT SHALL BE DONE WITH LIQUID TIGHT FLEXIBLE METAL CONDUIT. INSTALL GREEN GROUNDING CONDUCTOR.
- ALL FINAL BREAKERS AND CONDUCTORS SIZES SERVING MECHANICAL EQUIPMENT SHALL BE COORDINATED WITH MECHANICAL SHOP DRAWINGS AND CONTRACTOR PRIOR TO INSTALLATION. E.C. SHALL COORDINATE WITH HVAC CONTRACTORS EXACT POINT OF CONNECTION TO THE EQUIPMENT PRIOR TO ROUGH-IN.
- ALL EQUIPMENT INSTALLED OUTSIDE SHALL BE WEATHER PROOF RATED.

GENERAL NOTES (CONTINUE)

- REFER TO DRAWINGS FOR ADDITIONAL INFORMATION.
- INSTALL CONDUIT FROM THE TOP OF THE BAR JOIST.
 - LABEL ALL J-BOXES COVER PLATES, RECEPTACLES COVER PLATES WITH CIRCUIT INFORMATION AND PANEL SOURCE. UTILIZE P-TOUCH LABEL OR APPROVED EQUAL.
 - ALL MOUNTING HEIGHTS OF DEVICES SHALL BE COORDINATED WITH ARCHITECTURAL ELEVATIONS OR ARCHITECT PRIOR TO ROUGH-IN.
 - DO NOT INSTALL DEVICES IN DIFFERENT ROOMS BACK TO BACK. PROVIDE 6" SIDE BY SIDE IN BETWEEN.
 - WHEN APPLICABLE COORDINATE EXACT FURNITURE POWER REQUIREMENTS AND VOICE/DATA FEEDING CONNECTIONS AT EACH LOCATION PRIOR TO ROUGH-IN.
 - GENERAL USE RECEPTACLES SHALL BE WHITE IN COLOR WITH STEEL COVER PLATES. FINAL COLOR OF RECEPTACLES & COVER PLATES SHALL BE AS SELECTED BY THE OWNER.
 - E.C. SHALL INSTALL J-BOX AND CONDUIT FOR MECHANICAL THERMOSTATS. COORDINATE EXACT LOCATIONS WITH M.C. E.C. SHALL FURNISH AND INSTALL WIRING AND TERMINATE ALL LINE VOLTAGE THERMOSTATS.
 - FIRE PROOF ALL PENETRATIONS THRU WALLS AND FLOORS TO RE-ESTABLISH THE FIRE RATING OF PARTITION.
 - PROVIDE MULTI-GANG J-BOX FOR INSTALLATION OF WIRING DEVICES LOCATED AT THE SAME LOCATION UNLESS OTHERWISE INDICATED ON THE FLOOR PLANS. PROVIDE METALLIC DIVIDER PLATES BETWEEN DIFFERENT CIRCUITS IN THE SAME BOX.
 - ALL PULL BOXES AND JUNCTION BOXES SHALL BE SIZED PER ELECTRICAL CODE ARTICLE 314, TABLES 314.16 BASED IN THE AMOUNT OF CABLE AND CONDUITS ENTERING/LEAVING THE BOX.
 - VOICE/DATA/AUDIO VISUAL (AV) SYSTEMS CABLING AND EQUIPMENT SHALL BE PROVIDED BY LOW VOLTAGE CONTRACTOR. EC SHALL PROVIDE REQUIRED JUNCTION BOXES, CONDUIT, AND PULL STRING FOR ALL LOCATIONS.
 - FOR THE AREA OF WORK WITH DAMAGED, DETERIORATED, COMPROMISED OR MISSING FIREPROOFING CREATED OR EXPOSED DURING CONSTRUCTION SHALL BE RESTORED TO FULL PROTECTIVE CAPACITY.
 - ALL ELECTRICAL WORK SHALL MEET THE REQUIREMENTS OF THE 2015 INTERNATIONAL BUILDING CODE OR 2014 NATIONAL ELECTRICAL CODE

MOUNTING HEIGHTS

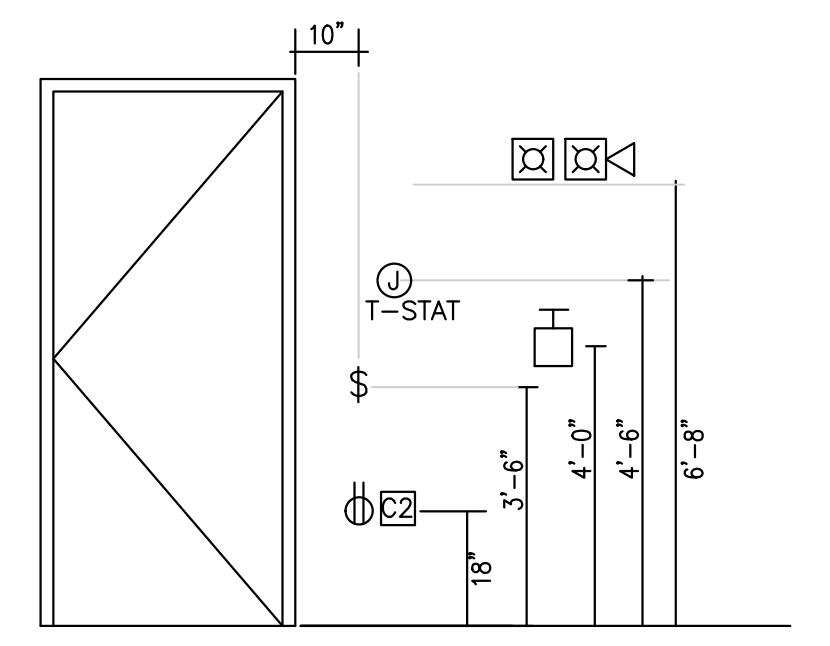

NOTES:
 1- ALL HEIGHTS FOR OUTLETS ARE AS INDICATED. COORDINATE WITH INTERIOR ARCHITECTURAL DRAWINGS. WHERE DIFFERENCES EXIST, USE ARCHITECTURAL MOUNTING HEIGHTS.

ELECTRIC AND VOICE/DATA OUTLETS

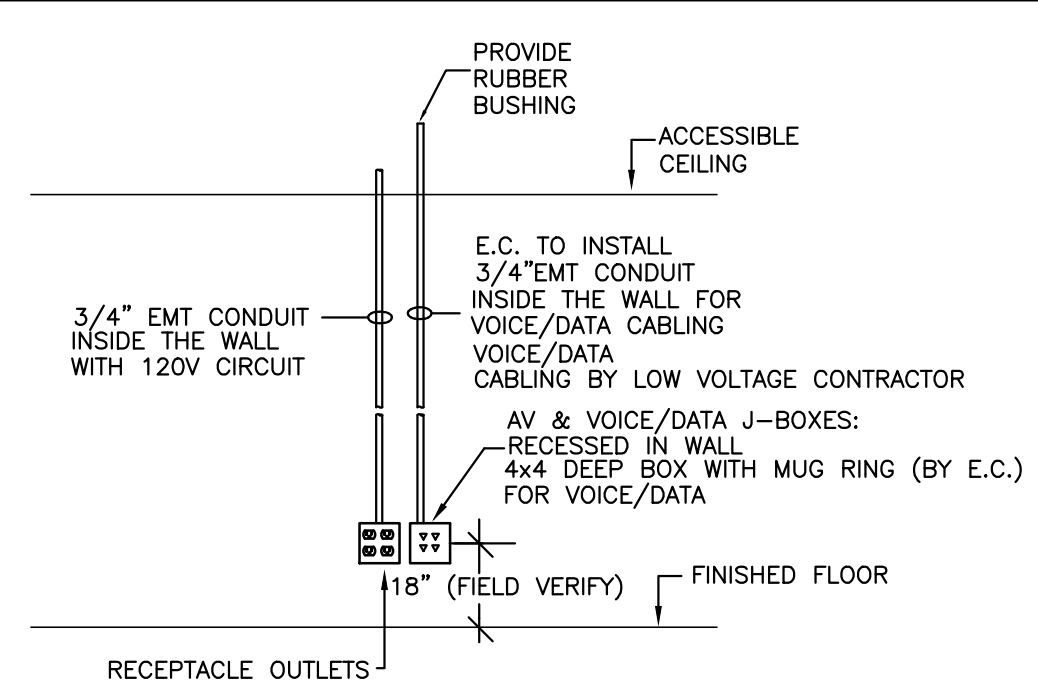

NOTE:
 1-ADJACENT POWER AND DATA/PHONE DEVICES SHALL BE SPACED NO MORE THAN 4" APART. PROVIDE JUNCTION BOX MOUNTING BRACKET BETWEEN STUDS AS NEEDED.
 2-ALL RECEPTACLE OUTLETS SHALL BE PROVIDED W/ P-TOUCH LABEL WITH CIRCUIT # AND SOURCE PANEL TAGS

ELECTRICAL SYMBOL LIST

- ⊕# DUPLEX RECEPTACLE, # INDICATES CIRCUIT
- ⊕ SIMPLEX RECEPTACLE
- C ⊕ SIMPLEX RECEPTACLE CLOCK STYLE
- GFI ⊕ DUPLEX RECEPTACLE, GROUND FAULT CIRCUIT INTERRUPTER
- U ⊕ DUPLEX RECEPTACLE, W/2 USB PORTS
- ⊕# QUAD RECEPTACLE (# INDICATES CIRCUIT)
- ⊕ AC QUAD RECEPTACLE MOUNTED ABOVE THE COUNTER. REFER TO ARCHITECTURAL ELEVATIONS FOR EXACT MOUNTING HEIGHT
- AS ⊕ DUPLEX RECEPTACLE MOUNTED AT SWITCH HEIGHT
- ⊕ SPECIAL RECEPTACLE COORDINATE EXACT REQUIREMENTS WITH EQUIP. SERVING
- ⊕ FLUSH MOUNTED FLOOR BOX WITH DUPLEX RECEPTACLE
- ⊕ FLOOR BOX (REFER TO FLOOR PLAN FOR REQUIREMENTS: PWR, VOICE/DATA & AV)
- ⊕ POKE THRU SEE DRAWING FOR REQUIREMENTS
- ⊕ PULL BOX
- \$ TOGGLE SWITCH SPECIFICATION GRADE
- \$ D TOGGLE SWITCH WITH DIMMER
- \$ 3 3-WAY TOGGLE SWITCH
- \$ K KEYSWITCH
- \$ M,K MOMENTARY CONTACT SWITCH - CENTER OFF
- \$ P RED PILOT LIGHT SWITCH (ON IN THE ON POSITION)
- \$ OS WALL SWITCH OCCUPANCY SENSOR
- \$ V VOLUME SWITCH
- ⊕ CEILING MOUNTED OCCUPANCY SENSOR
- ⊕ DAY LAMP SENSOR
- ⊕ PHOTOCELL FOR OVERRIDE TIME CLOCK FUNCTION
- ⊕ HEAVY DUTY FUSIBLE DISCONNECT SWITCH
- ⊕ HEAVY DUTY NON-FUSIBLE DISCONNECT SWITCH
- ⊕ JUNCTION BOX
- ⊕ SINGLE POLE DISCONNECT SWITCH TOGGLE STYLE
- ⊕ CONTROL TRANSFORMER WITH DISCONNECT SWITCH
- ⊕ MOTOR WITH MOTOR RATED DISCONNECT SWITCH.
- ⊕ HOT, NEUTRAL, GROUND CONDUCTOR IN RACEWAY
- ⊕ RACEWAY STUB UP TO ABOVE ACCESSIBLE CEILING WITH END BUSHING
- ⊕ CONDUIT CONCEALED IN WALL/ABOVE THE CEILING
- ⊕ CONDUIT IN CONCRETE SLAB/UNDERGROUND
- ⊕ EXPOSED CONDUIT
- ⊕ FLEXIBLE METAL CONDUIT
- ⊕ SLEEVE WITH END BUSHINGS ACC SIZE AS INDICATED IN DRAWINGS
- ⊕ (4x4 DEEP BOX WITH MUG RING AND ONE (1) 3/4" STUB UP VOICE OUTLET
- ⊕ (4x4 DEEP BOX WITH MUG RING AND ONE (1) 3/4" STUB UP VOICE/DATA OUTLET
- ⊕ (4x4 DEEP BOX WITH MUG RING AND ONE (1) 3/4" STUB UP AUDIO/VISUAL/DATA OUTLET
- ⊕ (4x4 DEEP BOX WITH MUG RING AND ONE (1) 1 1/4" STUB UP TO ACC WITH END BUSHING)
- ⊕ FIRE ALARM REMOTE BOOSTER POWER SUPPLY
- ⊕ FIRE ALARM DOUBLE ACTION PULL STATION
- ⊕ WALL MOUNTED FIRE ALARM STROBE (DEVICE W/ A "C" IS CEILING MTD)
- ⊕ WALL MOUNTED FIRE ALARM HORN/STROBE (W/ A "C" IS CEILING MTD)
- ⊕ FIRE ALARM PHOTOELECTRIC SMOKE DETECTOR
- ⊕ FIRE ALARM HEAT DETECTOR (SEE DRAWINGS FOR TYPE) 135FIX, 200FIX, RATE OF RISE (ROR)
- ⊕ FIRE ALARM DUCT SMOKE DETECTOR
- ⊕ FIRE ALARM DUCT DETECTOR REMOTE KEYED TEST SWITCH
- ⊕ FIRE ALARM MONITOR MODULE
- ⊕ FIRE ALARM CONTROL RELAY
- ⊕ CEILING MOUNTED SPEAKER
- ⊕ UNIVERSAL MOUNTED (CEILING/WALL) EXIT SIGN WITH CHEVRONS (SEE LIGHT FIXTURE SCHEDULE)
- ⊕ 2 x 4 SURFACE MOUNTED LIGHT FIXTURE (SEE LIGHT FIXTURE SCHEDULE)
- ⊕ 2 x 4 RECESSED MOUNTED LIGHT FIXTURE (SEE LIGHT FIXTURE SCHEDULE)
- ⊕ 2 x 2 RECESSED MOUNTED LIGHT FIXTURE (SEE LIGHT FIXTURE SCHEDULE)
- ⊕ NIGHT LIGHT FIXTURE (SEE LIGHT FIXTURE SCHEDULE)
- ⊕ LIGHT FIXTURE (SEE LIGHT FIXTURE SCHEDULE)
- ⊕ EMERGENCY LIGHT (SEE LIGHT FIXTURE SCHEDULE)
- ⊕ PANELBOARD
- ⊕ WAP WIRELESS ACCESS POINT

ABBREVIATIONS

- WP WEATHER PROOF
- WG WIRE GUARD
- AC ABOVE THE COUNTER
- C CEILING MOUNTED DEVICE
- NL NIGHT LIGHT
- CLG CEILING
- (R) RETURN DUCTWORK
- (S) SUPPLY DUCTWORK
- OHD OVERHEAD DOOR
- ACC ABOVE ACCESSIBLE CEILING
- VEL VERIFY EXACT LOCATION PRIOR TO ROUGH-IN
- +42 DEVICE MOUNTED AT 42 INCHES AFF
- AFF ABOVE FINISH FLOOR
- TR TAMPER RESISTANT
- TG TAMPER GUARD
- EWG ELECTRICAL WATER COOLER
- WP/ IN USE METAL WHILE-IN-USE COVER WEATHER PROOF SIMILAR TO EATON WJUMH-1 SERIES
- E.C. ELECTRICAL CONTRACTOR
- M.C. MECHANICAL CONTRACTOR
- S.C. SECURITY CONTRACTOR
- AHJ AUTHORITY HAVING JURISDICTION
- HD ELECTRICAL HAND DRYER
- IWH INSTANTANEOUS ELECTRICAL WATER HEATER
- X EXISTING DEVICE TO REMAIN
- XRR EXISTING DEVICE TO BE REMOVED AND RELOCATED
- XR EXISTING DEVICE RELOCATED
- N NEW DEVICE

ELECTRICAL DRAWING LIST

- E001 ELECTRICAL SYMBOL LIST, GENERAL NOTES AND DETAILS.
- ED201 PARTIAL SECOND FLOOR PLAN - ELECTRICAL DEMOLITION.
- E201 PARTIAL SECOND FLOOR PLANS - ELECTRICAL & LIGHTING.
- EM201 PARTIAL SECOND FLOOR PLANS - ELECTRO-MECHANICAL-PLUMBING
- E301 PARTIAL ELECTRICAL RISER DIAGRAM AND PANEL SCHEDULES.
- E401 LIGHTING FIXTURE SCHEDULE & DETAIL.
- E501 SPECIFICATION SHEET.

LAY-IN CEILING FIXTURE MOUNTING DETAIL

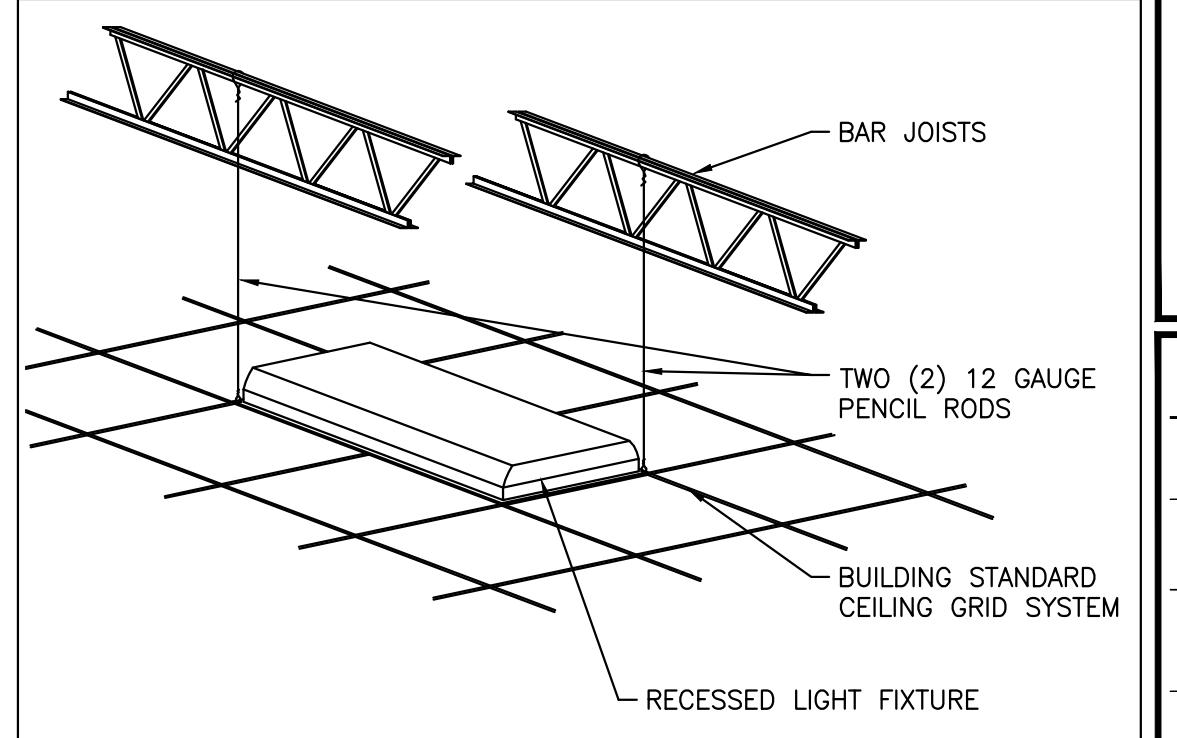

ALL LAY-IN LIGHT FIXTURES SHALL BE SUPPORTED INDEPENDENTLY OF CEILING GRID SUPPORTS. SUPPORT LIGHT FIXTURES WITH (2) 12 GAUGE PENCIL RODS LOCATED AT OPPOSITE CORNERS FROM TOP OF BAR JOISTS. SEE DETAIL ABOVE.

ELECTRICAL PLAN NOTES

- 1 RETROFIT EXISTING J-BOX LOCATION FOR NEW VOICE AND DATA OUTLET. COORDINATE WITH LOW VOLTAGE CONTRACTOR AND OWNER FOR EXACT REQUIREMENTS.
- 2 EXISTING BATHROOMS: CONTRACTOR SHALL CONNECT POWER AND LIGHTING IN EXISTING BATHROOMS TO CIRCUITS PPA:35 & PPB:35,37 (MEN) AND PPA:37 & PPB:39,41 (WOMEN). MODIFY EXISTING WIRING AS REQUIRED FOR A COMPLETE INSTALLATION AND OPERATING SYSTEM. SEE PANEL SCHEDULES FOR ADDITIONAL INFORMATION.
- 3 FURNISH AND INSTALL NEW FIRE ALARM DEVICE COMPATIBLE WITH EXISTING SYSTEM AND CONNECT FOR A COMPLETE INSTALLATION AND OPERATING SYSTEM.
- 4 FURNISH AND INSTALL NEW BLANK FINISHED COVER PLATE ON EXISTING OPEN J-BOX (TYPICAL FOR ALL APPLICABLE LOCATIONS)
- 5 MODIFY EXISTING RACEWAY AND WIRING SO AS TO CONNECT ELECTRICAL DEVICE TO CIRCUIT SHOWN.
- 6 REINSTALL EXISTING FIRE ALARM DEVICE AND CONNECT TO EXISTING SYSTEM FOR A COMPLETE INSTALLATION AND OPERATING SYSTEM.
- 7 UNDER BASE BID: CLEAN FIXTURES AND FURNISH AND INSTALL NEW FLUORESCENT LAMPS IN ALL EXISTING FLUORESCENT FIXTURES & PROVIDE PRISMATIC LENS IN EXISTING LIGHT FIXTURES WITH YELLOWED LENS. NEW LAMPS SHALL HAVE AN OUTPUT OF APPROX 2,600 LUMENS (MEANS), 4100K, AND 82 CRI.
 UNDER ALTERNATE BID: FURNISH AND INSTALL NEW TYPE "F1" LED LIGHT FIXTURES IN PLACE OF EXISTING.
- 8 INSTALL BLANK INSERT TO COVER LOCATION OF REMOVED CONTROL SWITCH.
- 9 FURNISH AND INSTALL NEW LED LAMP IN EXISTING SOCKET. CONTROL SHALL BE FROM EXISTING SWITCH.
- 10 MODIFY WIRING AS REQUIRED TO CONNECT FIXTURES AS SHOWN.
- 11 FLOOR BOX WITH POWER RECEPTACLES, VOICE/DATA AND AV CONNECTIVITY TO PROJECT IN MONITOR IN ROOM. COORDINATE EXACT LOCATION WITH OWNERS PROVIDED CONFERENCE TABLE.

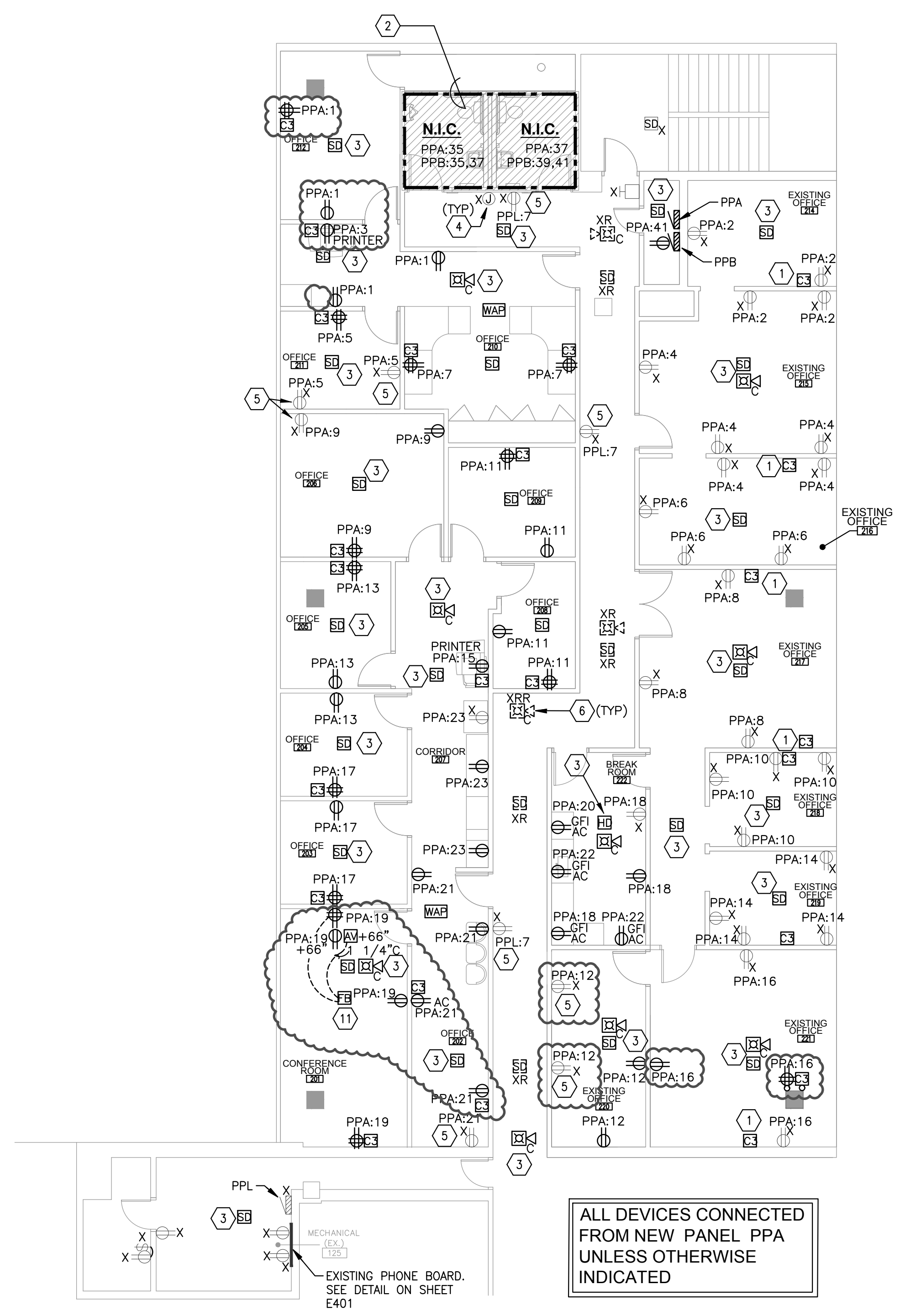

1 PARTIAL SECOND FLOOR PLAN - ELECTRICAL
 1/8" = 1'-0"
 0' 1' 2' 5' 10' 20'

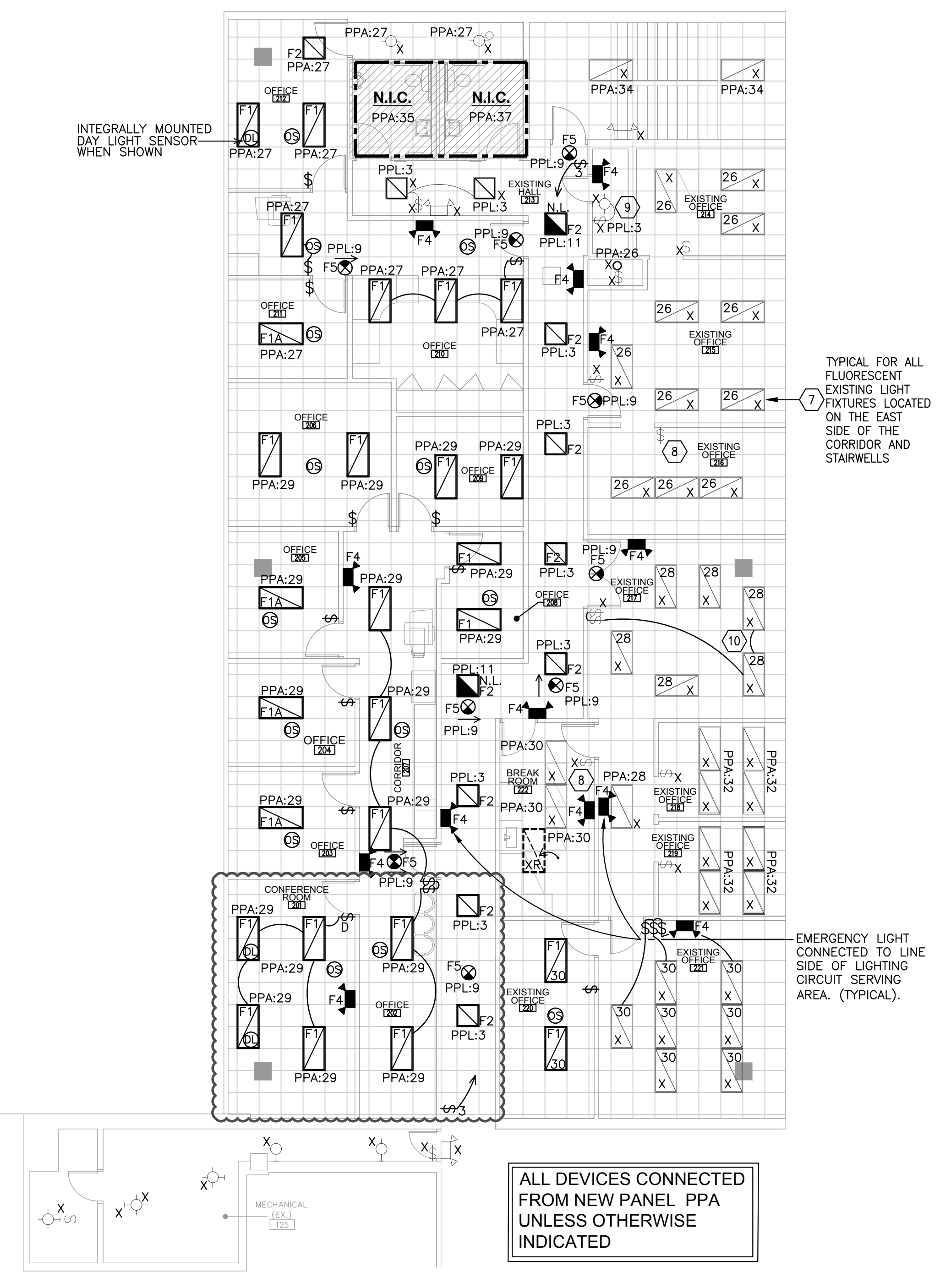

2 PARTIAL SECOND FLOOR PLAN - LIGHTING
 1/8" = 1'-0"
 0' 1' 2' 5' 10' 20'

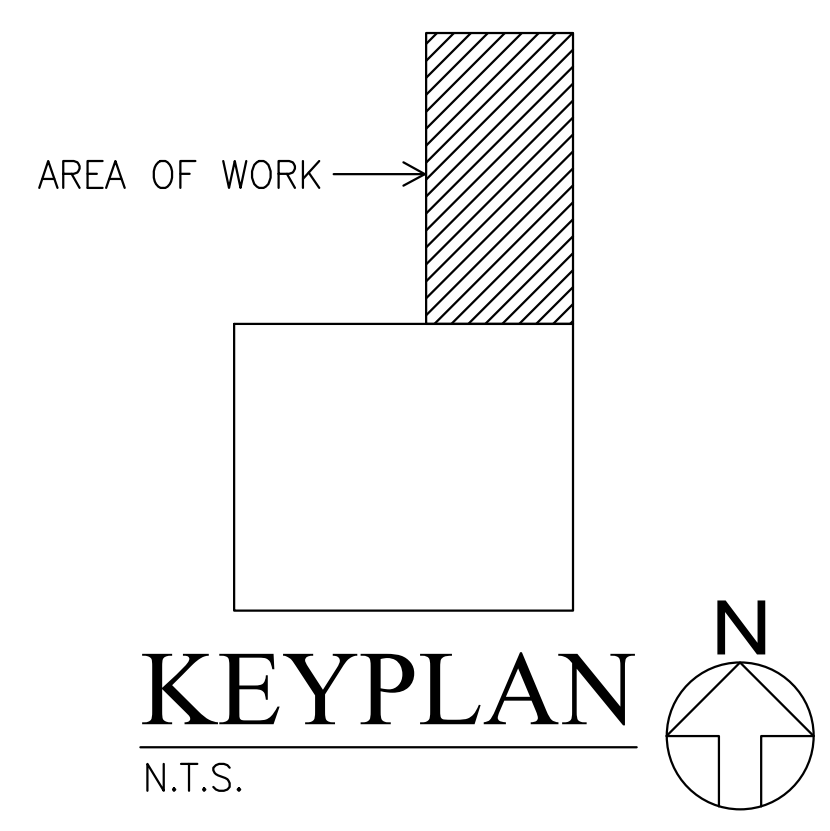

KEYPLAN
 N.T.S.

EXISTING PANEL PPL

PANEL: PPL		FRAME SIZE: 225A		VOLTAGE: 120 / 208							
LOCATION: MECHANICAL ROOM											
M.L.O. X											
FEEDER: EXISTING			FEEDER: EXISTING								
CKT NO.	BR	FAULT C.B.	CIRCUIT DESCRIPTION	PHASE A	PHASE B	PHASE C	CIRCUIT DESCRIPTION	FAULT C.B.	BR	CKT NO.	
1	20	1	LIGHTS EQUIP. RM.				LIGHTS & RECEPTS. BOILER RM.		20	1	
3	20	1	LIGHTS CORR.		326		SPARE		20	1	
5	20	1	WATER COOLER & JAN CLOSET NORTH			500	TEL. EQUIP.		20	1	
7	20	1	RECEPT. IN CORR.	600	500		TEL. EQUIP.		20	1	
9	20	1	L.O. EXIT LIGHTS		35		SPARE		20	1	
11	20	1	LIGHTS CORR NIGHT LIGHTS			68			20	1	
13	20	1	SPARE	0	0		SPARE		40	3	
15	20	1							20	1	
17	50	3	N RTU - 1 (6.5 TON)		3276	0			20	3	
19	20	1	SPARE		3276		SPARE		20	3	
21	20	1							20	3	
23	20	1				3276			20	3	
25	50	3	N RTU - 2 (6.5 TON)		3276		SPARE		30	3	
27	20	1			3276				20	3	
29	20	1	(SUB BREAKER) SPACE				(SUB BREAKER) SPARE		175	3	
TOTAL CONNECTED LOADS (VA)				7152	500	6913	0	6620	500	N - NEW BREAKER IN PLACE OF EXISTING	
TOTAL CONNECTED LOADS (VA)				7652		6913		7120		GFI BREAKER	
TOTAL AMPERAGE				60.19				-L.O. LOCK OUT			

EXISTING PANEL NOTES: E.C. REQUIRE TO PERFORM THIS WORK

- ELECTRICAL CONTRACTOR SHALL FIELD VERIFY EXACT CIRCUIT NUMBER INFORMATION PRIOR TO CONNECT CIRCUITS TO THE PANEL. CIRCUIT NUMBER INFORMATION HAVE BEEN GIVEN ONLY FOR INFORMATION PURPOSES BASED ON EXISTING PANEL CARD DIRECTORY. MODIFY CIRCUIT PANEL CONNECTIONS AND INFORMATION AS REQUIRED TO ACHIEVE THE PURPOSE.
- ELECTRICAL CONTRACTOR SHALL PROVIDE NEW UPDATED PANEL CARD DIRECTORY AFTER ALL CONNECTIONS HAVE BEEN COMPLETED. INSIDE PANEL EXISTING MARKER WRITING SHALL BE CLEANED SO THAT NOT MARKER WRITING IS VISIBLE. ALL NOT VALID INFORMATION SHALL BE DELETED.
- UTILIZE EXISTING EMPTY CIRCUITS/MODIFY CIRCUIT INFORMATION GIVEN AS REQUIRED FOR CONNECTION OF LOADS.
- PROVIDE UPDATED RECORD DOCUMENTS AFTER CONSTRUCTION IS DONE FOR FUTURE USE.
- FURNISH AND INSTALL NEW BREAKERS AS REQUIRED.
- ALL RECEPTACLE OUTLETS SHALL BE PROVIDED W/ P-TOUCH LABEL WITH CIRCUIT # AND SOURCE PANEL TAGS.

NEW PANEL - PPA

PANEL: PPA		FRAME SIZE: 225A		VOLTAGE: 120 / 208							
LOCATION: 2ND FLOOR NORTH ELECTRICAL CLOSET											
MAIN: 200A											
AIC: 22KAIC											
SERIES RATED											
WIRE: 4W											
CKT NO.	BR	FAULT C.B.	CIRCUIT DESCRIPTION	PHASE A	PHASE B	PHASE C	CIRCUIT DESCRIPTION	FAULT C.B.	BR	CKT NO.	
1	20	1	RECEPTS. OFFICE & HALL NEAR TO PRINTER	1000	800		RECEPTS. OFFICE 214		20	1	
3	20	1	PRINTER IN NORTHWEST OFFICE 210		1000	1000	RECEPTS. OFFICE 215		20	1	
5	20	1	RECEPTS. OFFICE 211			800	RECEPTS. OFFICE 216		20	1	
7	20	1	RECEPTS. OFFICE 210	800	600		RECEPTS. OFFICE 217		20	1	
9	20	1	RECEPTS. OFFICE 206		800	800	RECEPTS. OFFICES 218		20	1	
11	20	1	RECEPTS. OFFICE 208, 209			1200	RECEPTS. OFFICE 220		20	1	
13	20	1	RECEPTS. OFFICE 204 & 205	800	800		RECEPTS. OFFICE 219		20	1	
15	20	1	PRINTER BY OFFICE 208		1000	1000	RECEPTS. OFFICE 221		20	1	
17	20	1	RECEPTS. OFFICES 204 & 203			1000	RECEPT. BREAK ROOM (GFIAC)		20	1	
19	20	1	CONFERENCE ROOM 201	1400	1500		RECEPT. BREAK ROOM (GFIAC)		20	1	
21	20	1	OFFICE 202		1000	1500	RECEPT. BREAK ROOM (GFIAC)		20	1	
23	20	1	RECEPTS. CORR 207 ABOVE COUNTER			400	RECEPT. OFFICE 220		20	1	
25	20	1	SPARE	600	1872		LIGHTING OFFICE 214-216		20	1	
27	20	1	LIGHTING OFFICES 210-212		291	1092	LIGHTING OFFICE 217		20	1	
29	20	1	LIGHTING OFFICES 201-209			761	LIGHTING OFFICE 220, 221		20	1	
31	20	1	SPARE	1248			LIGHTING OFFICE 218, 219		20	1	
33	20	1	RECP. EF AND LIGHTING BATHROOM MEN		500	400	LIGHTING NORTH STAIR		20	1	
35	20	1	RECP. EF AND LIGHTING BATHROOM WOMEN			500	SPARE		20	1	
37	20	1	SPARE				SPARE		20	1	
39	20	1	SPARE				SPARE		20	1	
41	20	1	RECEPT BELOW PANEL			200	SPARE		20	1	
TOTAL CONNECTED LOADS (VA)				4600	6820	4591	5792	4861	5460		
TOTAL CONNECTED LOADS (VA)				11420		10383		10321		GFI BREAKER	
TOTAL AMPERAGE				89.17				-L.O. LOCK OUT			

NEW PANEL - PPB

PANEL: PPB		FRAME SIZE: 225A		VOLTAGE: 120 / 208							
LOCATION: 2ND FLOOR NORTH ELECTRICAL CLOSET											
MAIN: 200A											
AIC: 22KAIC											
SERIES RATED											
WIRE: 4W											
CKT NO.	BR	FAULT C.B.	CIRCUIT DESCRIPTION	PHASE A	PHASE B	PHASE C	CIRCUIT DESCRIPTION	FAULT C.B.	BR	CKT NO.	
1	20	1	EBB - 2 OFFICE 212	900	900		EBB - 2 OFFICE 214		20	1	
3	20	1	EBB - 2 OFFICE 212		900	900	EBB - 2 OFFICE 215		20	1	
5	20	1	EBB - 2 OFFICE 211			900	EBB - 2 OFFICE 215		20	1	
7	20	1	EBB - 1 OFFICE 206	1200	1200		EBB - 1 OFFICE 216		20	1	
9	20	1	EBB - 1 OFFICE 205		1200	900	EBB - 2 OFFICE 217		20	1	
11	20	1	EBB - 1 OFFICE 204			1200	EBB - 1 OFFICE 217		20	1	
13	20	1	EBB - 1 OFFICE 203	1200	900		EBB - 2 OFFICE 218		20	1	
15	20	1	EBB - 1 OFFICE 202		1200	900	EBB - 2 OFFICE 219		20	1	
17	20	1	EBB - 1 OFFICE 201			1200	EBB - 1 OFFICE 221		20	1	
19	30	2	EWHP - 1 (ELECT HEAT STAIRS)	2400	1200		EBB - 1 OFFICE 221		20	1	
21	20	1	SPARE		2400				20	1	
23	20	1	RECEPTS. RTU-1 & RTU-2			400			20	1	
25	25	1	ELECTRICAL WATER HEATER	1500					20	1	
27	20	2	PLUMBING WASTE HEAT TAPE		2000				20	1	
29	20	2	PLUMBING WASTE HEAT TAPE			2000			20	1	
31	20	2	PLUMBING WASTE HEAT TAPE	2000					20	1	
33	20	2	PLUMBING WASTE HEAT TAPE		2000				20	1	
35	20	2	MEN BATHROOM CUH	1000					20	1	
37	20	2	WOMEN BATHROOM CUH		1000				20	1	
39	20	2							20	1	
41	20	2							20	1	
TOTAL CONNECTED LOADS (VA)				10200	4200	10700	2700	7700	3300		
TOTAL CONNECTED LOADS (VA)				14400		13400		11000		GFI BREAKER	
TOTAL AMPERAGE				107.70				-L.O. LOCK OUT			

PANELBOARD PLAN NOTES

- ELECTRICAL CONTRACTOR SHALL COORDINATE WITH THE PLUMBING CONTRACTOR FOR EXACT HEAT TAPE SYSTEM POINT OF CONNECTION(S) AND EXACT POWER REQUIREMENTS PRIOR TO INSTALL. PROVIDE NEUTRAL CONDUCTOR IF REQUIRED FOR 120V LOADS. E.C. SHALL PROVIDE J-BOX AND SAFETY DISCONNECT SWITCH WITH PROPER LABEL FOR EACH CONNECTION.

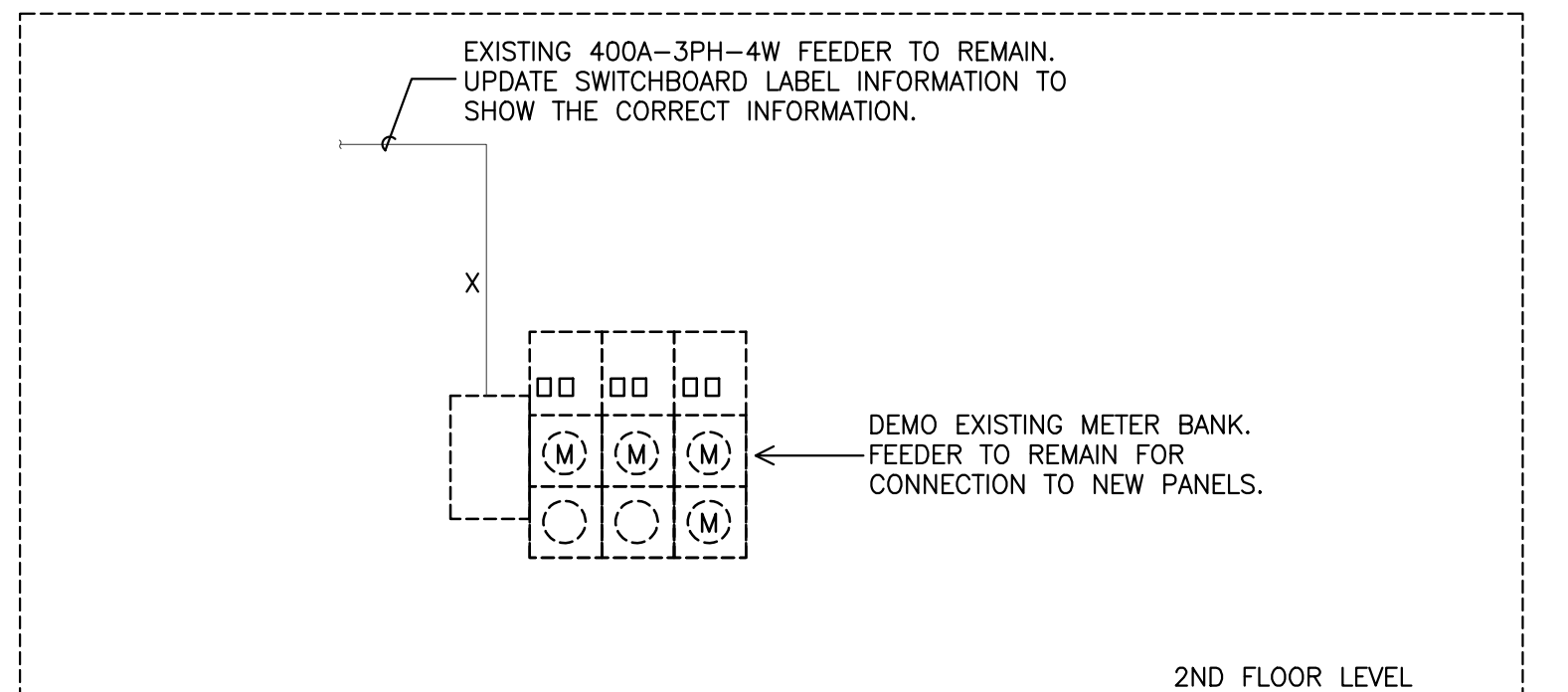

PARTIAL ELECTRICAL RISER DIAGRAM - DEMOLITION

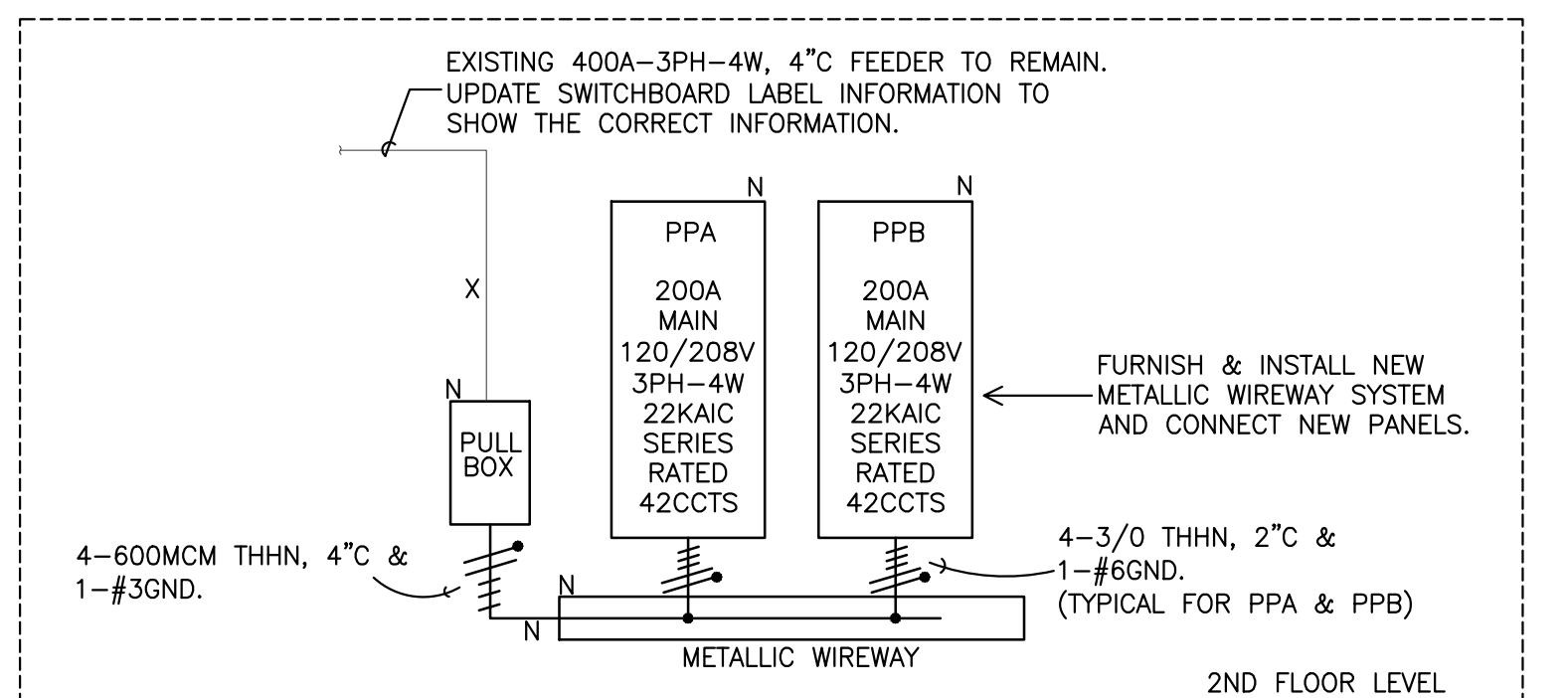

PARTIAL ELECTRICAL RISER DIAGRAM - PROPOSED

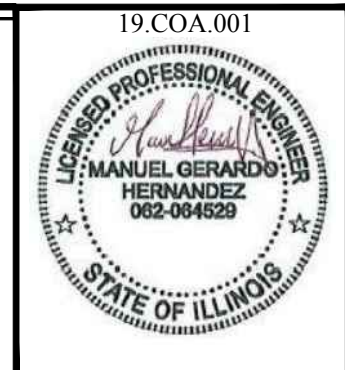

DSC NORTH - SECOND FLOOR
77 S. BROADWAY
AURORA, IL 60505

MGH Consulting Engineers, LLC
ENGINEERING
LICENSE NO. 184.007392-0002
408 S. Highland Ave. Arlington Heights, IL 60005
mghrande@mghe.com Phone: 773.314.7819

PARTIAL ELECTRICAL RISER DIAGRAM & PANEL SCHEDULES

ISSUED:
3-19-19 ISSUED FOR REVIEW
4-8-19 ISSUED FOR PERMIT
4-23-19 ISSUED FOR PERMIT COMMENTS

E301

LIGHTING FIXTURE SCHEDULE									
FIXTURE TAG	SYMBOL	MANUFACTURER	MODEL NUMBER	LAMPS	VOLTAGE	WATTAGE	MOUNTING	NOTES	
F1		METALUX	24CZ-LD5-40-UNV-LB40-CD1-U (PROVIDE DAY LIGHT SENSOR (DL) WHEN INDICATE IN PLAN)	LED 4000K-82CRI 4043lm	120V-277V	29W	RECESSED	2x4 LED RECESSED LIGHT FIXTURE.	
F1A		METALUX	24CZ-LD5-50-UNV-LB40-CD1-U	LED 4000K-82CRI 5088lm	120V-277V	41W	RECESSED	2x4 LED RECESSED LIGHT FIXTURE.	
F2		METALUX	22CZ-LD4-34-UNV-LB40-CD1-U (PROVIDE DAY LIGHT SENSOR (DL) WHEN INDICATE IN PLAN)	LED 4000K-82CRI 3400lm	120V-277V	34W	RECESSED	2x2 LED RECESSED LIGHT FIXTURE.	
F3		PORTFOLIO	LDA6A15835D010TE LAR35FL 6FLC1	LED 3500K-80CRI 1500lm	120V-277V	22.9W	RECESSED	LED 6" RECESSED ROUND CAN LIGHT	
F4		SURE-LITES	XR1624CSD	(2) 12W 6V	120V-277V	10W	SURFACE WALL	EMERGENCY LIGHT WITH (2) LAMPS AND BATTERY BACK UP FOR NINETY (90) MINUTE OF BATTERY BACK-UP ILLUMINATION TIME	
F5		SURE-LITES	CX7(1 OR 2)WH-SD20	LED	UNIVERSAL 120V-277V	5W	WALL/CEILING	LED EXIT SIGN W/ RED LETTERS AND EMERG. BATT. (SINGLE OR DOUBLE FACE & CHEVRONS AS REQD). SHALL HAVE A NINETY (90) MINUTE BATT. BACK-UP ILLUM. TIME	

ALL MANUAL OCCUPANCY SENSORS SHALL BE
 MANUAL ON, VACANCY OFF AS REQUIRED
 BY IECC2015 UNLESS OTHERWISE INDICATED
 STRICTLY IN THE DRAWINGS.

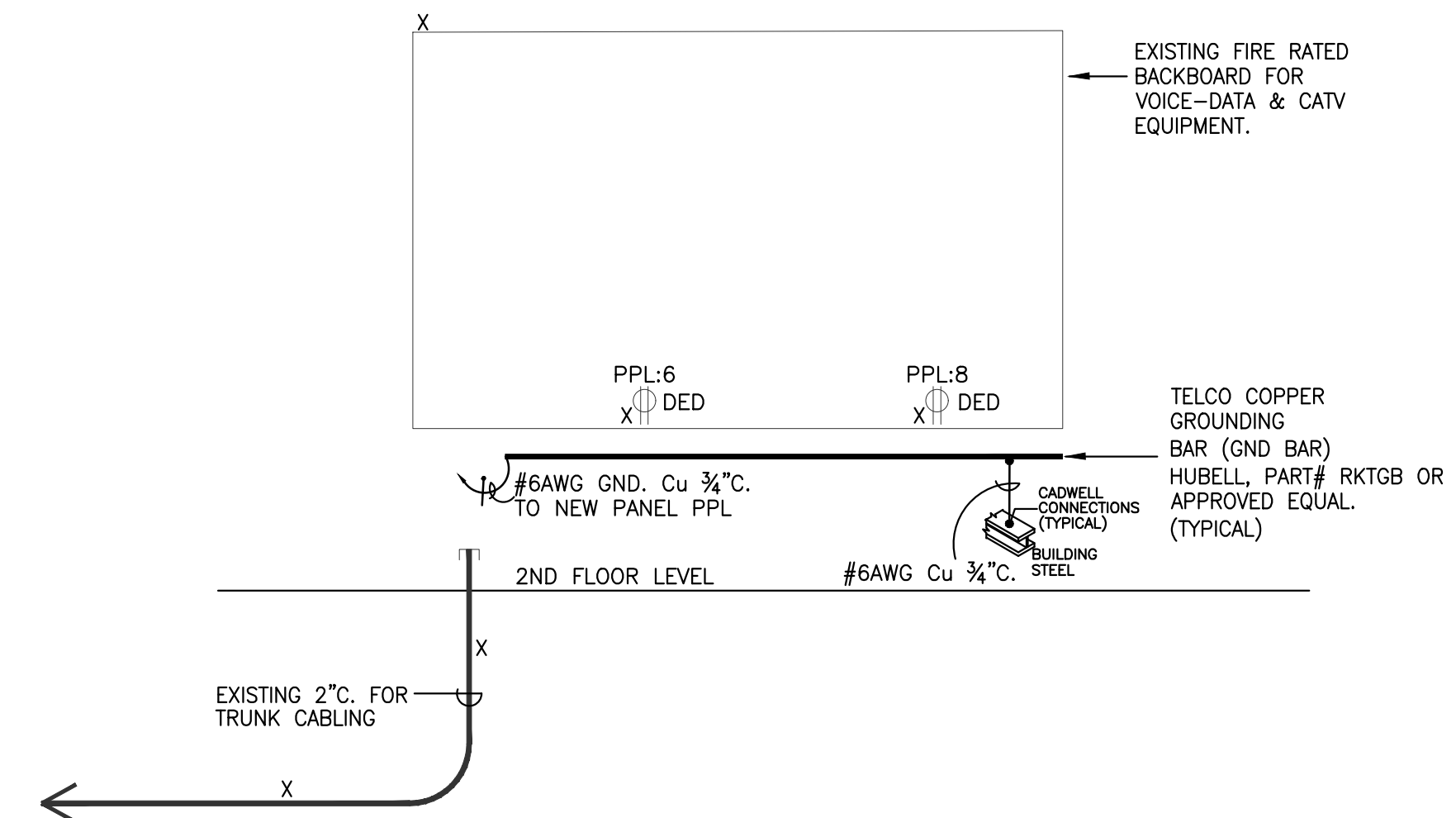
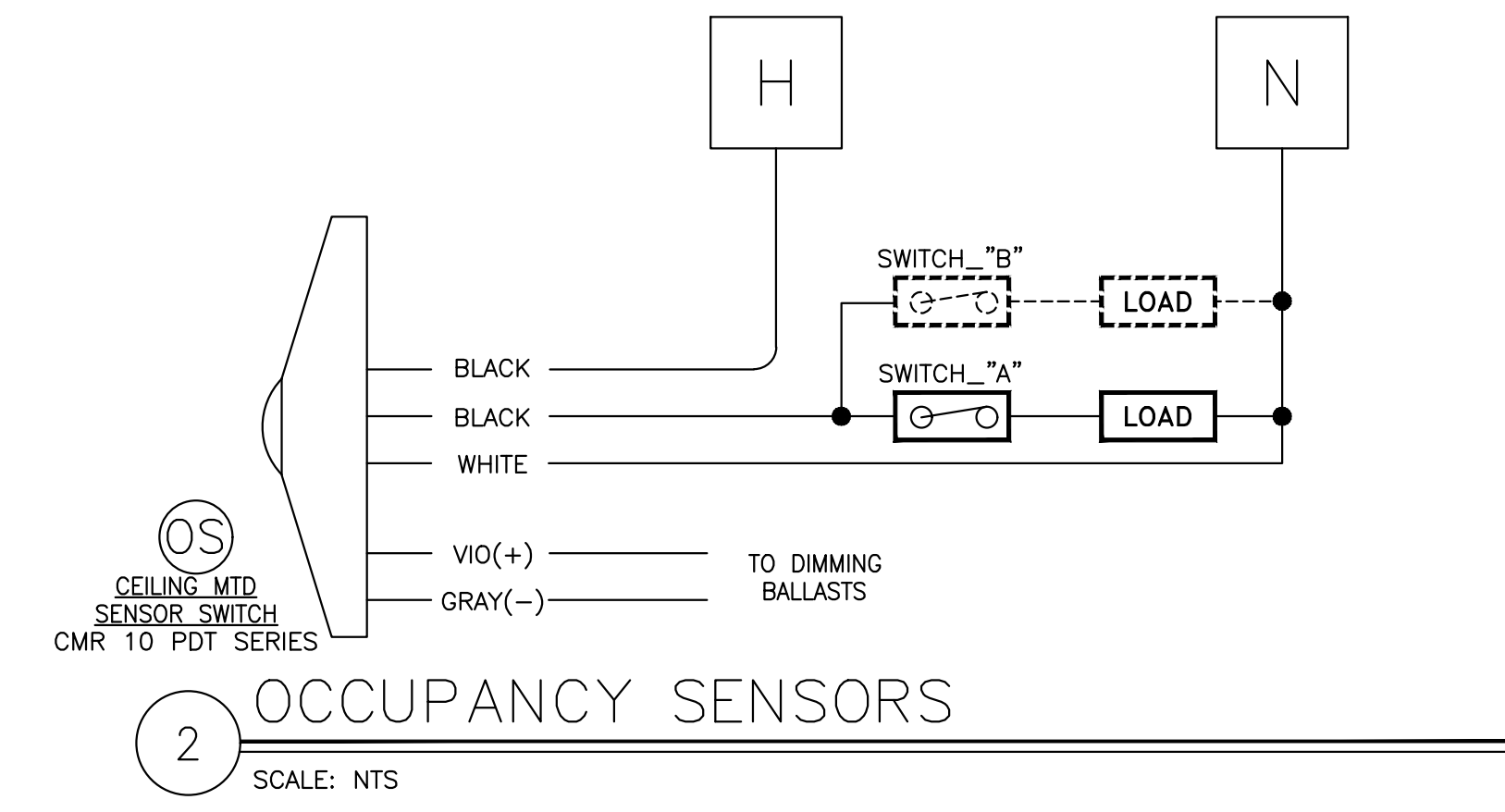
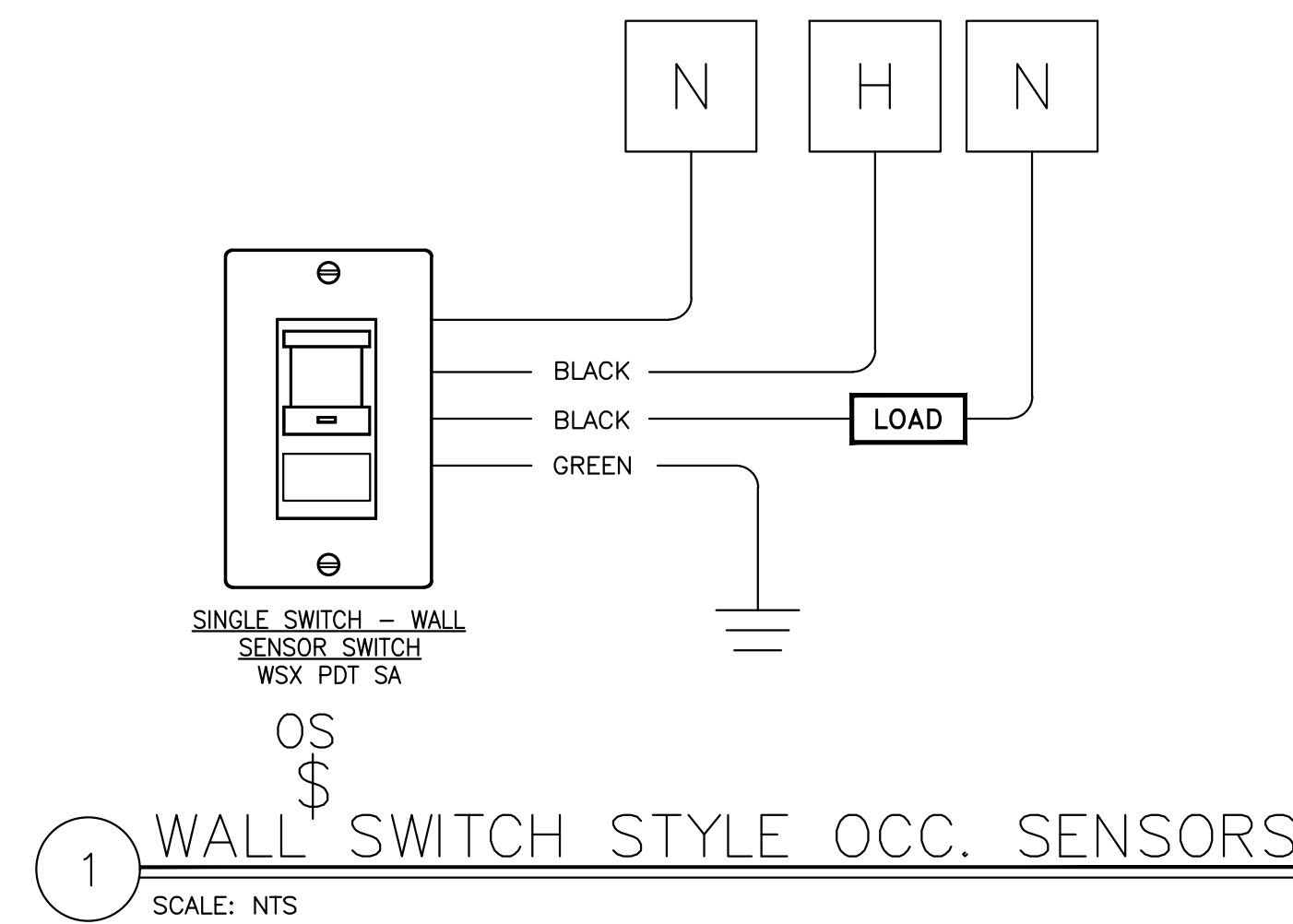

GENERAL DEMOLITION NOTES

- EACH CONTRACTOR SHALL REVIEW THE EXISTING SYSTEMS IN THE FIELD ALONG WITH BID DOCUMENTS AND DETERMINE SELECTIVE DEMO AND ADDITION OF TEMPORARY SYSTEMS (IF REQUIRED) TO MAKE PHASED DEMO AND PROPOSED REMODELING. IT SHALL ASSURE UNINTERRUPTED SAFE OPERATION OF AREAS THAT ARE AFFECTED BY DEMO AND ADDITION OF PROPOSED SYSTEMS AT ALL TIMES. INCLUDE THE NECESSARY WORK TO ACCOMPLISH THIS AND COORDINATE PHASING ACCORDINGLY.
- CONFIRM WITH THE MANUFACTURERS OF EXISTING EQUIPMENT THAT IS TO BE REUSED OR EXTENDED.
- WHERE EXISTING ELECTRICAL WORK PREVENTS PROPER CONSTRUCTION OF NEW WORK AS INDICATED, REMOVE, REROUTE, RELOCATE, OR IN OTHER WAYS ALTER EXISTING WORK IN ORDER TO ACCOMMODATE.
- WHERE EXISTING CONDUIT, WIRE, SUPPORTS, HANGERS AND OTHER ELECTRICAL WORK MUST BE REMOVED AS A RESULT OF THE ALTERATIONS, THEY SHALL BE COMPLETELY REMOVED, BACK TO THE FIRST OUTLET WHICH IS LEFT UNAFFECTED BY THE DEMOLITION. CONDUIT WHICH IS BURIED IN CONCRETE OR OTHERWISE INACCESSIBLY POSITIONED MAY BE ABANDONED. IN SUCH CASES, WIRE SHALL BE PULLED OUT AND THE CONDUIT SHALL BE PLUGGED AT EACH END.
- EXISTING ELECTRICAL MATERIALS AND EQUIPMENT, INCLUDING LIGHTING FIXTURES, SWITCHES, RECEPTACLES, SIGNAL LIGHTS, SPEAKERS, INTERCOM EQUIPMENT, CONTROLS, CONDUIT OUTLETS, FITTINGS, AND OTHER DEVICES REMOVED AS A RESULT OF THE ALTERATIONS SHALL REMAIN THE PROPERTY OF THE OWNER AND SHALL BE REUSED WHERE INDICATED UNLESS OTHERWISE INDICATED.
- EXAMINE THE CONDITION OF ANY SUCH MATERIALS AND EQUIPMENT TO MAKE A PRIOR DETERMINATION OF WHETHER IT IS SUITABLE FOR REUSE. PRESENT FINDINGS TO THE ENGINEER WHO WILL IN TURN MAKE THE FINAL DECISION REGARDING REUSABILITY. ALL WIRE AND CABLE FOR REUSED AND RELOCATED EQUIPMENT SHALL BE NEW.
- IN ORDER TO COORDINATE THE WORK OF THE MECHANICAL AND ELECTRICAL TRADES, REMOVE EXISTING ELECTRICAL WORK IN AND ABOVE CEILING OF THESE AREAS (AS REQUIRED), AFTER WHICH INSTALL NEW WORK AND REINSTALL EXISTING WORK TO REMAIN, AS SHOWN ON THE DRAWINGS. EXISTING MATERIALS AND EQUIPMENT SHALL BE REUSED ONLY WHERE INDICATED.
- SOME EXCEPTIONS MAY ARISE WHEREIN EQUIPMENT, EITHER IN ALTERED AREAS OR OTHER AREAS, MUST BE KEPT IN SERVICE, REQUIRING THAT FEEDERS, SIGNAL CONDUCTORS, CONDUITS, BOXES, ETC. SERVING SAME ALSO BE KEPT IN SERVICE. IN SUCH CASES, THOSE ELECTRICAL FEEDERS, SIGNAL CONDUCTORS, CONDUITS, ETC. SHALL BE REROUTED AND RECONNECTED BEFORE PRESENT WORK IS REMOVED. IF THIS IS NOT POSSIBLE, TEMPORARY WIRING SHALL BE PROVIDED, AFTER WHICH NEW WORK SHALL BE INSTALLED AND TEMPORARY WIRING REMOVED.
- ANY ELECTRICAL EQUIPMENT THAT IS TAGGED TO BE DISPOSED OF SHALL BE DONE PER APPROVED METHOD IN ACCORDANCE WITH THE CONSTRUCTION PLAN AND LOCAL AUTHORITIES.
- THIS DRAWING INDICATES AREAS THAT ARE BEING AFFECTED BY THE DEMOLITION. DASHED LINES SHOW EXISTING MATERIALS AND EQUIPMENT TO BE REMOVED. SOLID LINES SHOW EXISTING MATERIALS AND EQUIPMENT TO REMAIN (X). ELECTRICAL CONTRACTOR SHALL REMOVE ALL ELECTRICAL EQUIPMENT AFFECTED BY THE DEMOLITION AND WILL KEEP REMAINING EQUIPMENT CONNECTED, POWERED TO THE EXISTING CIRCUITS AS REQUIRED.
- THIS DRAWING SHOWS A REPRESENTATIVE SAMPLE OF DEMOLITION WORK THAT IS TO TAKE PLACE. NOTE THAT NOT EVERY DEVICE, LIGHTING FIXTURE, CONDUIT ETC. REQUIRED TO BE DEMOLISHED IS NECESSARILY INDICATED ON THIS PLAN. THE CONTRACTOR SHALL VISIT THE JOB SITE TO FAMILIARIZE HIMSELF/HERSELF WITH THE EXTENT OF EXISTING WORK TO BE DEMOLISHED.
- ALL PROPOSED DEMOLITION WORK SHALL BE THOROUGHLY COORDINATED WITH ALL OTHER TRADES.
- MAINTAIN AND RESTORE, IF INTERRUPTED, ALL CONDUITS, FEEDERS AND BRANCH CIRCUITS PASSING THROUGH RENOVATED AREA AND SERVING UNDISTURBED AREAS.
- ANY PORTION OF THE EXISTING CONDUIT SYSTEM THAT IS TO BE REUSED FOR THE NEW INSTALLATION SHALL BE CHECKED TO ENSURE THAT IT IS CLEAN, FREE OF DAMAGE, FREE OF CORROSION, AND ADEQUATELY SUPPORTED. REMOVED RACEWAY SHALL NOT BE RE-USE.
- DISCONNECT AND REMOVE ALL ELECTRICAL EQUIPMENT, DEVICES AND CONDUITS IN WALLS, FLOORS AND CEILING SCHEDULED FOR DEMOLITION.
- EXISTING ELECTRICAL SYSTEM IS DESCRIBED BASED ON SURVEYS OF EXISTING CONDITIONS THAT WERE VISIBLE DURING THE SURVEY. CONTRACTOR SHALL CONFIRM ALL SERVICES PRIOR TO PROCEEDING WITH DEMOLITION.
- PATCH ALL HOLES IN SLABS, WALLS AND CEILING WHERE ELECTRICAL DEVICES AND/OR CONDUIT ARE REMOVED. IF THE REMOVAL OF CONDUIT, BOXES, EQUIPMENT, ETC. COMPROMISES THE FIRE RATING OF THESE ITEMS, THE CONTRACTOR SHALL SEAL OPENINGS WITH CODE APPROVED FIRE STOPPING MATERIAL TO RE-ESTABLISH THE ORIGINAL RATE OF PARTITION.
- WHERE FEEDERS OR BRANCH CIRCUITS ARE DISCONNECTED AND REMOVED FROM EXISTING PANEL BOARDS, CONTRACTOR SHALL MARK THE AFFECTED BREAKERS IN THOSE PANEL BOARDS AS "SPARE". INSTALL NEW KNOCK-OUT BLANK INSERT IN PANEL BOX.
- CONTRACTOR IS TO PERFORM DEMOLITION WORK IN A NEAT, SKILLFUL, AND CAREFUL MANNER SO AS NOT TO DAMAGE OR DEFACE EXISTING CONSTRUCTION THAT IS TO REMAIN.
- VERIFY THAT REMOVAL OF DEVICES IN RENOVATED AREA DOES NOT AFFECT DEVICES IN OTHER AREAS THAT MAY BE FED FROM THE CIRCUIT BEING DISCONNECTED. BYPASS RACEWAY AND WIRING AS REQUIRED TO KEEP REMAINING DEVICES OPERATIONAL.
- ALL ABANDONED AND/OR UNUSED COMPONENTS CREATED OR EXPOSED DURING CONSTRUCTION, INCLUDING BUT NOT LIMITED TO CABLES, WIRING, RACEWAY, J-BOXES AND ASSOCIATED SUPPORTS AND OR ATTACHMENTS SHALL BE REMOVED.
- RETAIN EXISTING CONDUIT, JUNCTION BOXES, AND CIRCUITING AS APPLICABLE WHEN IT MAKE SENSE, AND WHEN IN GOOD CONDITIONS.
- REMOVE ALL LOW VOLTAGE CABLING INDICATED UNDER DEMOLITION BACK TO THE SOURCE. ALL CABLING, HANGERS, TIES AND CONDUIT ARE TO BE REMOVED ENTIRELY. PROVIDE NEW CABLING, JACKS & COVER PLATES FOR ALL VOICE/DATA OUTLETS. CONFIRM CABLING REQUIREMENTS WITH OWNER.

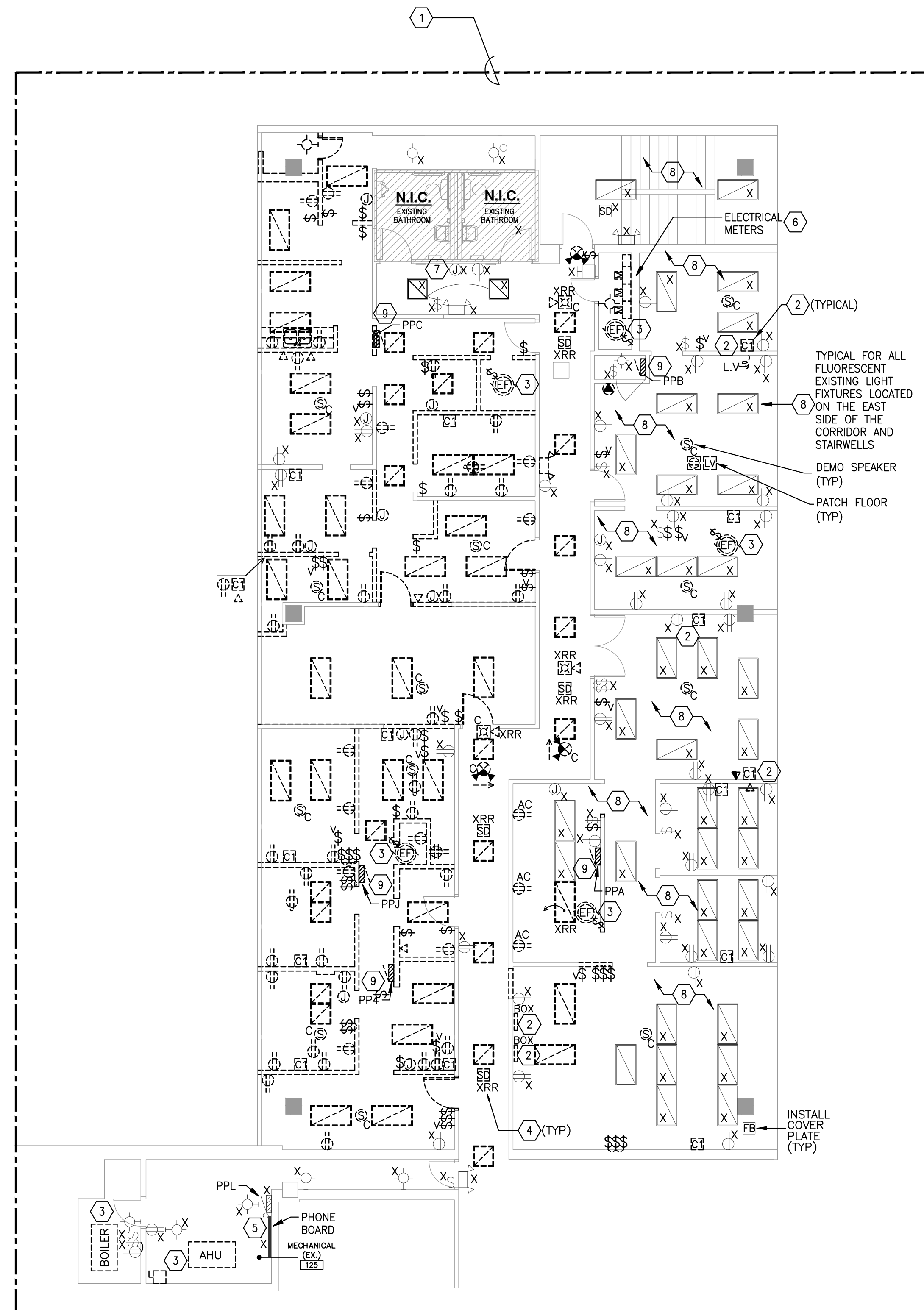

1 PARTIAL SECOND FLOOR PLAN – ELECTRICAL DEMOLITION
1/8" = 1'-0"

0' 1' 2' 5' 10' 20'

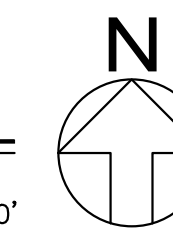

ELECTRICAL DEMOLITION PLAN NOTES

- ELECTRICAL DEVICES INDICATED UNDER DEMOLITION (NOT TAGGED WITH "X") OR IN THE WAY OF NEW CONSTRUCTION SHALL BE DISCONNECTED AND REMOVED. REMOVED RACEWAY AND WIRING BACK TO SOURCE. UPDATE PANEL CARD DIRECTORY TO REFLECT NEW CHANGES. DISPOSE OF LAMPS PER E.P.A. REQUIREMENTS. DEVICES LABELED "XRR" ARE EXISTING DEVICES TO BE REMOVED AND RELOCATED. RETAIN THOSE DEVICES FOR REINSTALLATIONS AT NEW LOCATIONS. ALL EMPTY CIRCUITS SHALL BE REMOVE BACK TO PANEL, TURN OFF BREAKER AND LABEL "SPARE".
- REMOVE EXISTING VOICE/DATA CABLING BACK TO SOURCE. J-BOX TO REMAIN FOR INSTALLATION OF NEW VOICE AND DATA OUTLET; OTHERWISE, FURNISH AND INSTALL BLANK FINISHED COVER PLATE TO MATCH NEW FINISH.
- DISCONNECT ABANDONED MECHANICAL EQUIPMENT AND REMOVE RACEWAY AND WIRING BACK TO PANEL. REMOVE ASSOCIATED DISCONNECT SWITCH OR CONTROL SWITCH AS REQUIRED. UPDATE PANEL CARD DIRECTORY.
- FIRE ALARM NOTIFICATION OR INITIATING DEVICES TO BE DISCONNECTED, REMOVED AND RETAINED FOR REINSTALLATION AT NEW LOCATION. INSTALL SMOKE DETECTORS COVER CAPS TO AVOID DAMAGE WITH CONSTRUCTION DUST. REFER TO NEW WORK FOR ADDITIONAL INFORMATION.
- REMOVE ALL EXISTING PHONE TERMINAL BLOCKS AND CABLING. PHONE BOARD TO REMAIN. PREPARE EXISTING BOARD TO RECEIVE NEW VOICE/DATA EQUIPMENT. COORDINATE WITH OWNER FOR EXTEND OF WORK.
- REMOVE EXISTING METER BANK. 400A FEEDER TO REMAIN FOR CONNECTION TO NEW PANELS. REFER TO NEW WORK AND TO PARTIAL RISER DIAGRAM ON SHEET E301 FOR ADDITIONAL INFORMATION.
- FURNISH AND INSTALL BLANK FINISHED COVER PLATE ON EXISTING J-BOX
- UNDER BASE BID:**
CLEAN FIXTURES AND FURNISH AND INSTALL NEW FLUORESCENT LAMPS IN ALL EXISTING FLUORESCENT FIXTURES & PROVIDE PRISMATIC LENS IN EXISTING LIGHT FIXTURES WITH YELLOWED LENS. NEW LAMPS SHALL HAVE AN OUTPUT OF APROX 2,600 LUMENS (MEANS), 4100K, AND 82 CRI.
- UNDER ALTERNATE BID:**
FURNISH AND INSTALL NEW TYPE "F1" LED LIGHT FIXTURES IN PLACE OF EXISTING.
- EXISTING PANEL TO BE DISCONNECTED AND REMOVED. REMOVE FEEDER BACK TO SOURCE INCLUDING RACEWAY AND WIRING. REMOVE STILL ACTIVE BRANCHES BACK TO UNAFFECTED AREA FOR EXTENSION OF EXISTING CIRCUITS TO NEW PANEL. REMOVE EMPTY BRANCHES BACK COMPLETE. SEE NEW WORK FOR ADDITIONAL INFORMATION.

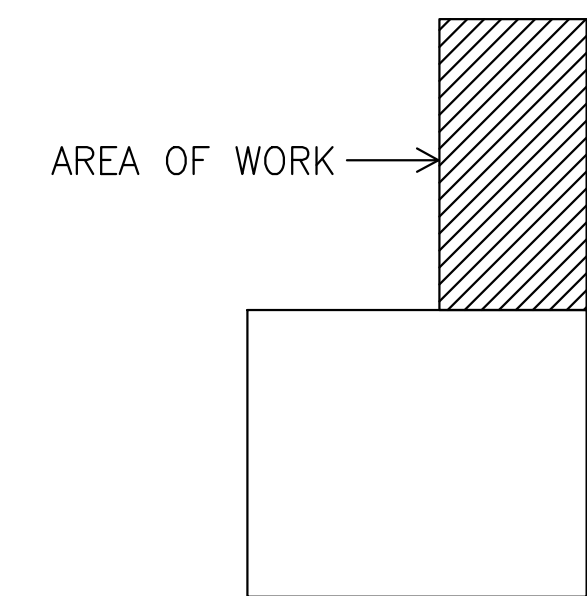

KEYPLAN
N.T.S.

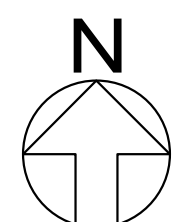

DSC NORTH - SECOND FLOOR
77 S. BROADWAY
AURORA, IL 60505

MGH ENGINEERING
MGH Consulting Engineers, LLC
LICENSE NO. 184.007392-0002
408 S. Highland Ave. Arlington Heights, IL 60005
mgh@mghe.com Phone: 773.314.1219

PARTIAL SECOND FLOOR PLAN - ELECTRICAL DEMOLITION

ISSUED:
3-19-19 ISSUED FOR REVIEW
4-8-19 ISSUED FOR PERMIT
4-23-19 ISSUED FOR PERMIT COMMENTS

ED201

ELECTRICAL PLAN NOTES

- 1 DISCONNECT SWITCH AND SERVICE RECEPTACLE PROVIDED INTEGRALLY MOUNTED WITH MECHANICAL UNIT. COORDINATE EXACT POINT OF CONNECTION TO MECHANICAL UNIT PRIOR TO ROUGH-IN. E.C. SHALL PROVIDE ALL INTERCONNECTIONS AS REQUIRED FOR A COMPLETE INSTALLATION AND OPERATING SYSTEM. CORE DOWN THRU ROOF NEXT TO UNIT (DO NOT RUN FEEDERS ON ROOF. FILL RACEWAYS SERVING POWER AND CONTROL WITH APPROVED SEALANT MATERIAL TO PREVENT THE CIRCULATION OF COLDER AIR TO WARMER SECTIONS OF THE RACEWAY OR SLEEVE TO PREVENT CONDENSATION.
- 2 DISCONNECT SWITCH PROVIDED INTEGRALLY MOUNTED WITH MECHANICAL UNIT. UNIT SHALL BE INSTALLED IN FIRST FLOOR BY EXIT DOOR. THE INTENT OF THIS ELECTRICAL UNIT HEATER IS TO TEMPER THE STAIRWELL.
- 3 DISCONNECT SWITCH PROVIDED INTEGRALLY MOUNTED WITH MECHANICAL UNIT.

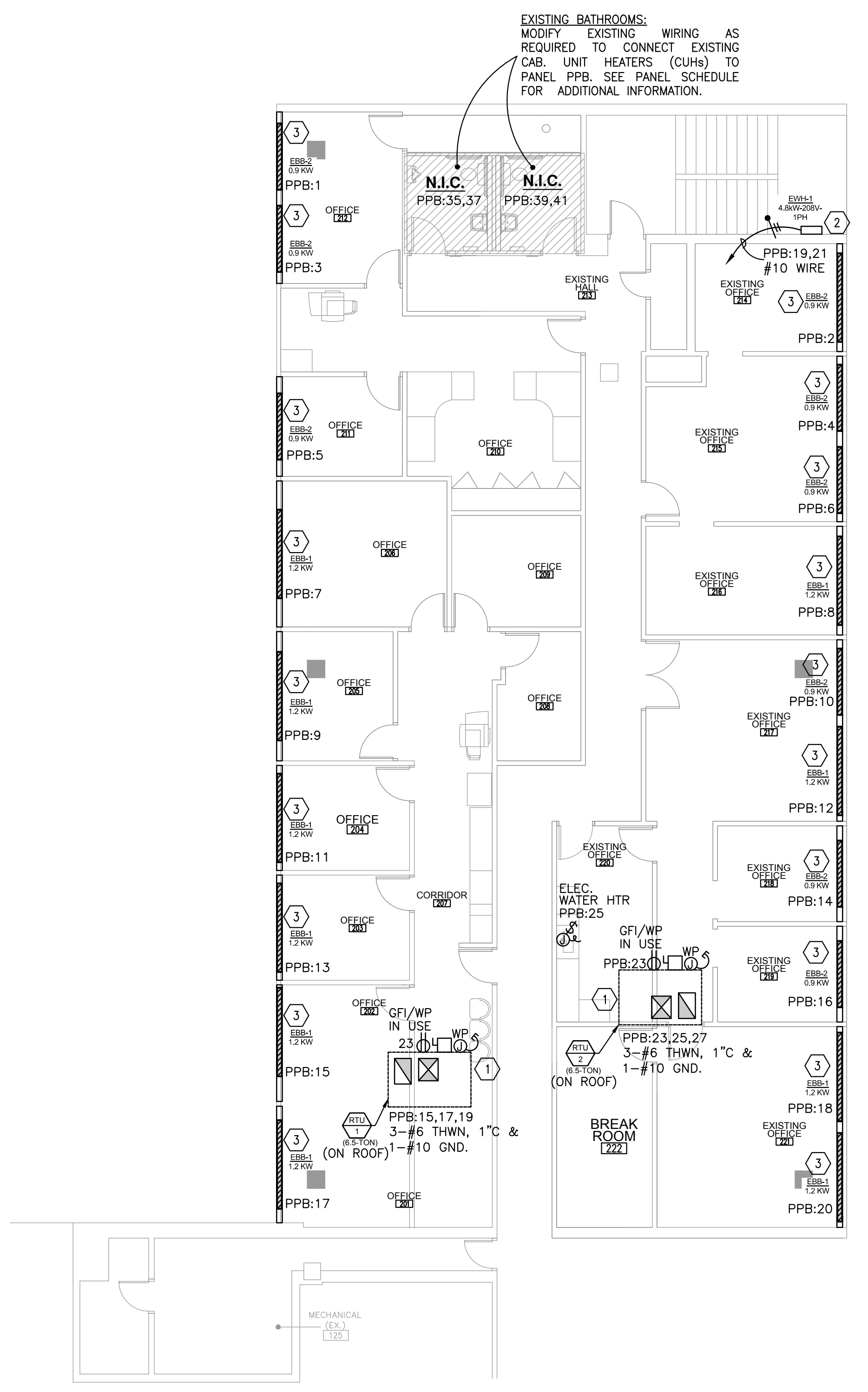

EXISTING BATHROOMS:
 MODIFY EXISTING WIRING AS REQUIRED TO CONNECT EXISTING CAB. UNIT HEATERS (CUHs) TO PANEL PPB. SEE PANEL SCHEDULE FOR ADDITIONAL INFORMATION.

1 PARTIAL SECOND FLOOR PLAN - ELECTRO-MECHANICAL-PLUMBING
 1/8" = 1'-0"

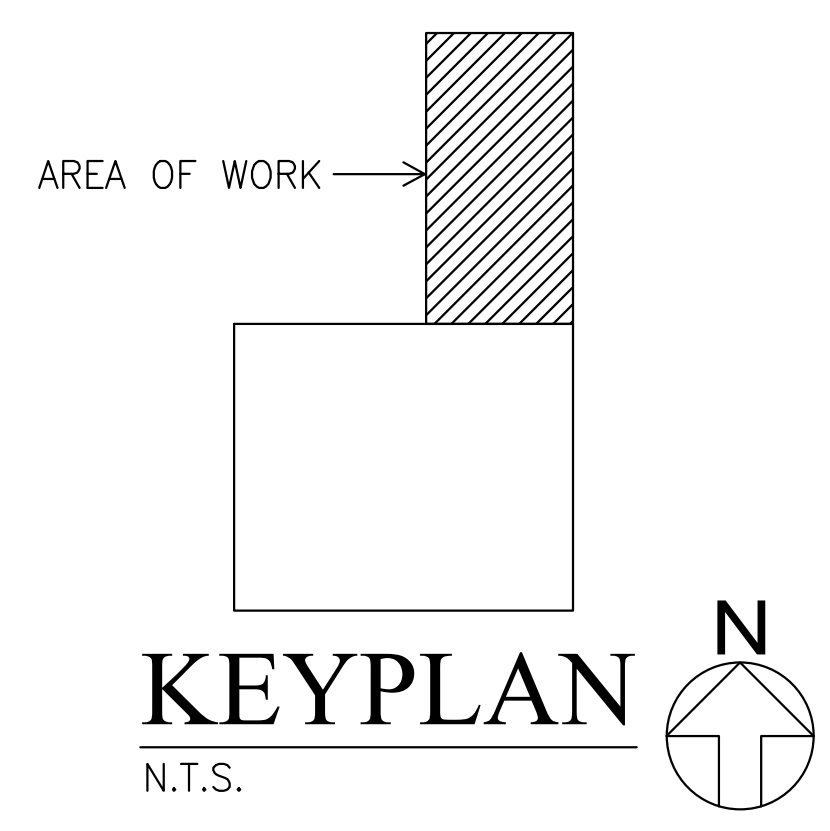
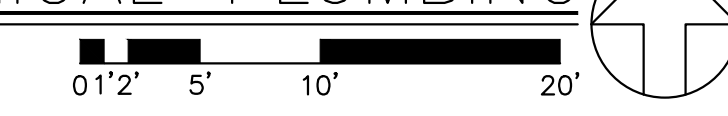

PACKAGED ROOF TOP UNIT SCHEDULE (RTU)																					
TAG	MANUFACTURER / MODEL #	TONS	EER (SEER)	BLOWER SECTION				COOLING CAPACITY				HEATING CAPACITY			ELECTRICAL DATA		WEIGHT [LBS]	NOTES			
				CFM	O.A. CFM	ESP [IN W.C.]	DRIVE	FAN POWER [HP]	# OF COMP.	TYPE	REFRIG. TYPE	NET [MBH]	GROSS [MBH]	INPUT [MBH]	OUTPUT [MBH]	AFUE [%]			V/PH/Hz	MCA	MOCF
RTU-1	YORK / ZJ078	6.5	11.8	2600	500	1.0	DIRECT	1.5	2	SCROLL	R-410A	77.0	80.5	120	96.0	81	208/3/60	34.1	45	1,200	1-12
RTU-2	YORK / ZJ078	6.5	11.8	2600	500	1.0	DIRECT	1.5	2	SCROLL	R-410A	77.0	80.5	120	96.0	81	208/3/60	34.1	45	1,200	1-12

REMARKS:

- PROVIDE 14" PREFAB ROOF CURB.
- OUTSIDE AIR INTAKE SHALL BE 10'-0" MINIMUM AWAY FROM ANY EXHAUST DISCHARGE.
- PROVIDE 7-DAY FULLY PROGRAMMABLE WALL MOUNTED HEATING/COOLING/FAN THERMOSTAT WITH OCCUPIED/UNOCCUPIED MODES.
- PROVIDE FLEXIBLE CANVAS CONNECTIONS AT SUPPLY AND RETURN DUCT CONNECTIONS.
- PROVIDE GAS PIPING, UNION, GAS COCK AND DIRT LEG CONNECTIONS TO UNIT.
- PROVIDE FACTORY UNIT MOUNTED DISCONNECT SWITCH AND GFIMP SERVICE RECEPTACLE. FIELD WIRING BY ELECTRICAL CONTRACTOR.
- PROVIDE LOW LEAK ECONOMIZER & FAULT DIAGNOSTIC AND DETECTION (FDD).
- SMOKE DETECTORS SHALL BE PROVIDED AND INSTALLED BY FIRE ALARM CONTRACTOR.
- HAIL GUARDS.
- UNIT MUST BE 2015 IECC COMPLIANT. CONFIRM ALL REQUIRED ACCESSORIES WITH SALES REP.
- PROVIDE WITH POWERED EXHAUST.
- PROVIDE WITH INTELLISPEED OPTION.

ELECTRIC WALL HEATER SCHEDULE							
TAG	MANUFACTURER AND MODEL NO.	DESCRIPTION	KW	MBH	AMPS	ELECTRICAL	REMARKS
EW-1	"QMARK" #CWH3508F	WALL MOUNTED UNIT HEATER	4.8	17.0	23.1	208-1-60	1, 2, 3

REMARKS:

- VERIFY EXACT VOLTAGE PRIOR TO ORDERING EQUIPMENT
- HARDWIRED WITH FACTORY DISCONNECT
- PROVIDE W/ RECESSED FRAME AND INTEGRAL THERMOSTAT.

AIR DEVICE SCHEDULE								
TAG	MAKE / MODEL	TYPE	SERVICE	MATERIAL	SIZE	NECK SIZE	MAX N.C.	REMARKS
A	TITUS / TMS	ARCHITECTURAL SQUARE DIFFUSER	SUPPLY	STEEL	24x24	SEE PLAN	25	1, 2, 4
B	TITUS / 350 RL	LOUVER GRILLE	RETURN	STEEL	24x12	22x10	25	1, 2.

REMARKS:

- WHITE FINISH
- ARCHITECTURAL PLAQUE: TO BE INSTALLED FOR LAY-IN CEILING
- PROVIDE SQUARE TO ROUND ADAPTER WHERE REQUIRED
- PROVIDE WITH TITUS "FLEXABOOT" SOUND ATTENUATION ASSEMBLY

ELECTRIC BASEBOARD HEATER SCHEDULE										
TAG	LENGTH	CAPACITY (KW)	ELECTRICAL DATA				WEIGHT (LBS)	MANUFACTURER AND MODEL	REMARKS	
			MCA	MOCF	VOLT	PH HZ				
EBB-1	8'0"	1.2	10	20	120	1	60	20	QMARK - DBSL06	1, 2, 3
EBB-2	6'0"	0.9	7.54	20	120	1	60	24	QMARK - DBSL06	1, 2, 3

REMARKS:

- PROVIDE FACTORY MOUNTED DISCONNECT SWITCH, BLANK SECTIONS, & END CAPS TO PROVIDE A CONTINUOUS LOOK.
- BASEBOARD SHALL BE FLOOR MOUNTED WITH FRONT-INLET
- PROVIDE WITH LOCAL THERMOSTAT.
- COORDINATE UNIT COLOR WITH ARCHITECT AND OWNER PRIOR TO ORDERING.

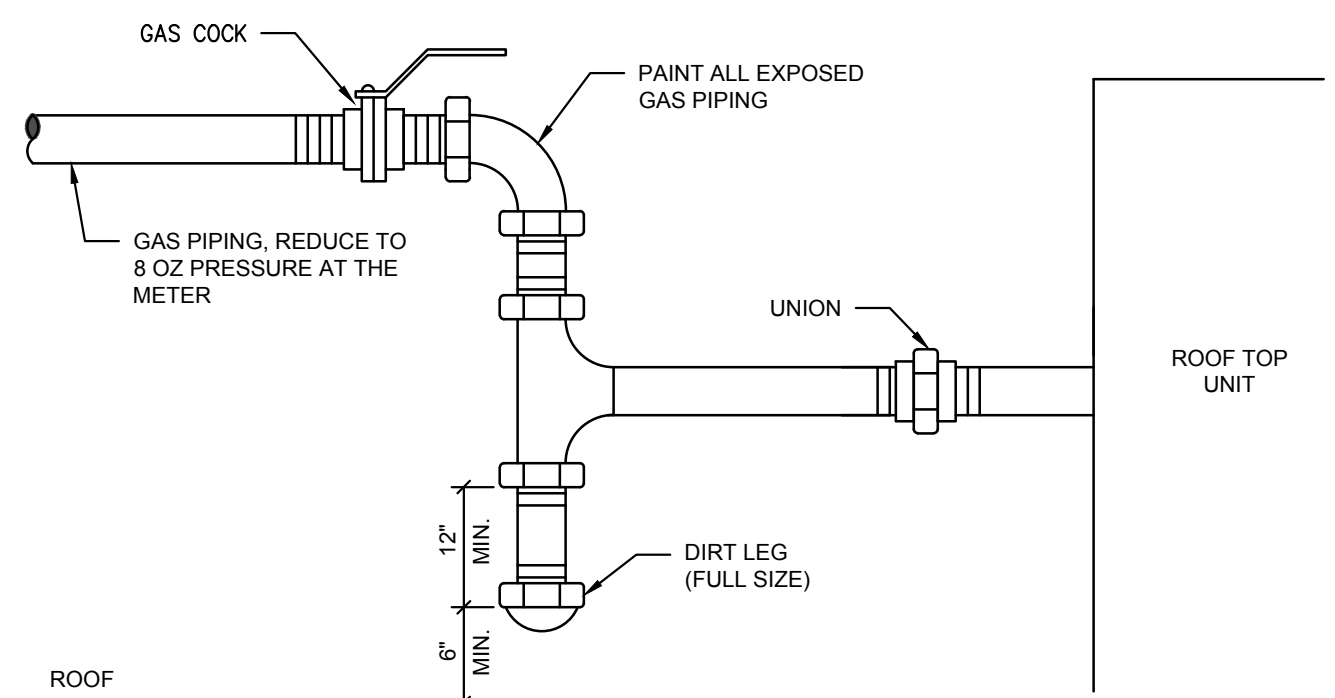

GAS COCK DETAIL
NO SCALE

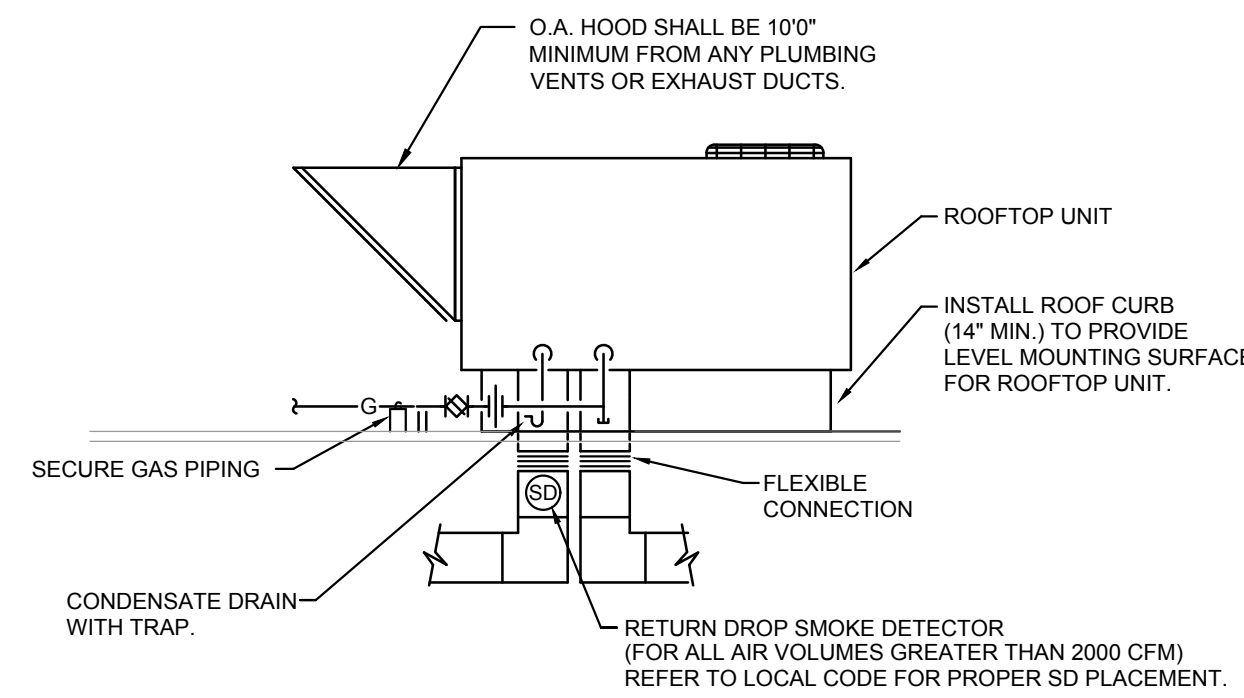

ROOF TOP UNIT DETAIL
NO SCALE

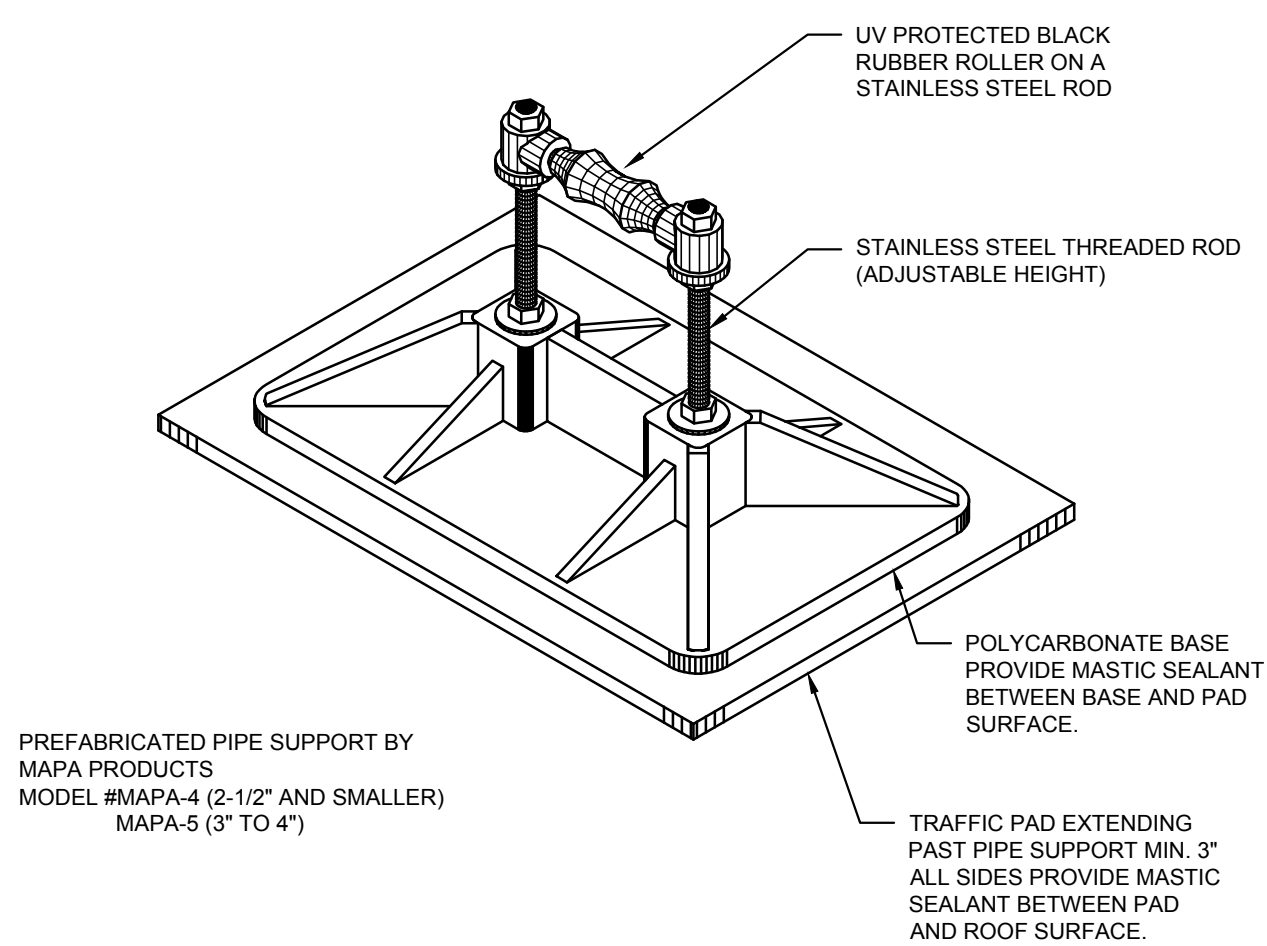

ROOF PIPE SUPPORT DETAIL
NO SCALE

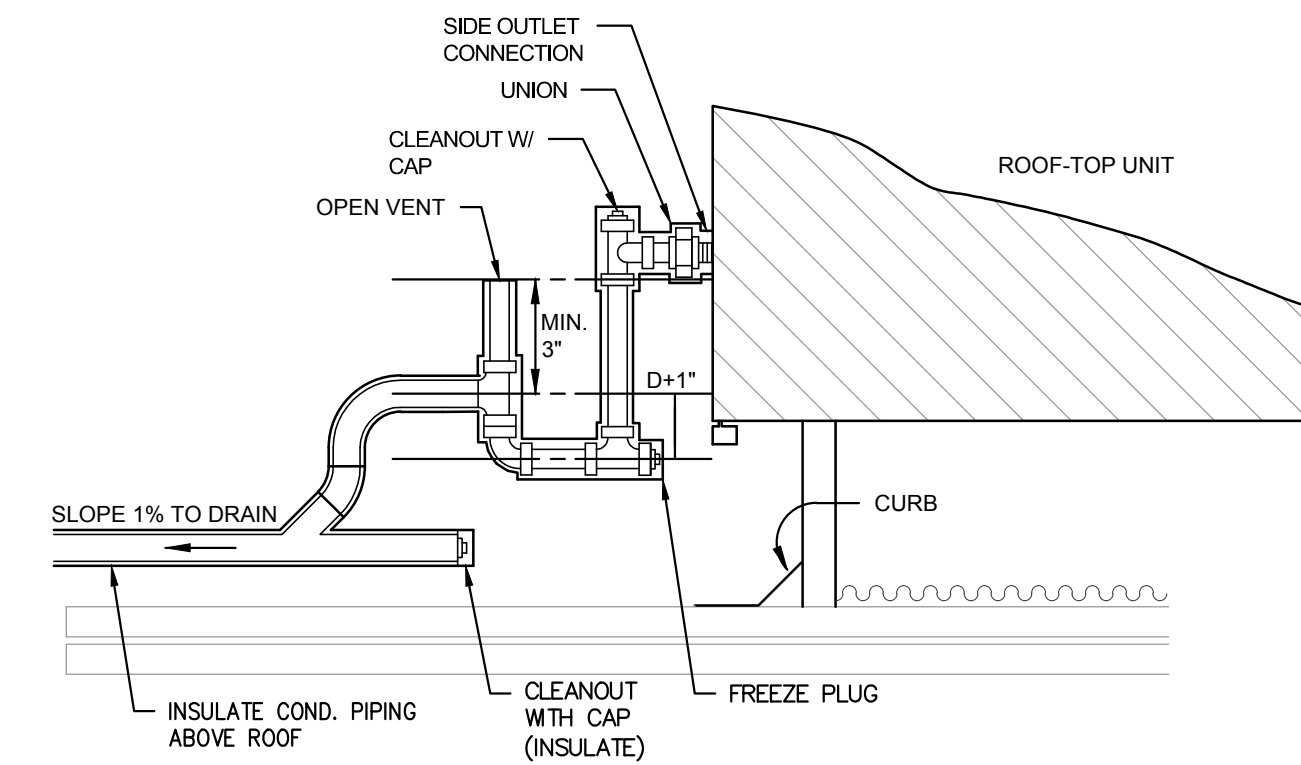

ROOFTOP UNIT CONDENSATE PIPING DETAIL
NO SCALE

GENERAL NOTES

- ALL WORK SHALL BE IN ACCORDANCE WITH ALL STATE AND LOCAL APPLICABLE CODES.
- ALL EQUIPMENT SHALL BE U.L., ETL, AND/OR AGA LABELED AS REQUIRED.
- ALL DUCTWORK SHALL BE PRIME GRADE GALVANIZED SHEET METAL PER SMACNA STANDARDS.
- DUCTWORK SHALL BE SUPPORTED WITH APPROVED HANGERS AT INTERVALS NOT EXCEEDING TEN (10) FEET OR BY OTHER APPROVED DUCT SUPPORT SYSTEMS DESIGNED IN ACCORDANCE WITH THE BUILDING CODE. FLEXIBLE AND OTHER FACTORY-MADE DUCTS SHALL BE SUPPORTED IN ACCORDANCE WITH THE MANUFACTURER'S INSTALLATION INSTRUCTIONS.
- MECHANICAL CONTRACTOR SHALL PROVIDE SPIN-IN COLLARS WITH DAMPERS AT ALL ROUND BRANCH TAKEOFFS TO DIFFUSERS.
- DUCTWORK CONSTRUCTION MATERIALS, INCLUDING COVERINGS, LININGS, AND ADHESIVES, EXPOSED WITHIN PLENUMS SHALL BE NONCOMBUSTIBLE OR SHALL HAVE A FLAME SPREAD RATING OF NOT MORE THAN 25 AND A SMOKE DEVELOPED RATING OF NOT MORE THAN 50 WHEN TESTED IN ACCORDANCE WITH ASTM E-84.
- PROVIDE FIRE DAMPERS BY "NAILOR" OR APPROVED EQUAL AT ALL PENETRATIONS THRU RATED ASSEMBLIES. REFER TO ARCHITECTURAL PLANS FOR ALL LOCATIONS AND RATINGS. ALL FIRE DAMPERS MAY NOT BE SHOWN ON THE PLANS. THIS CONTRACTOR SHALL VERIFY EXACT LOCATIONS AND QUANTITIES.
- MECHANICAL CONTRACTOR SHALL PROVIDE FLEXIBLE CANVAS CONNECTIONS AT ALL EQUIPMENT.
- MECHANICAL CONTRACTOR SHALL PROVIDE FLEXIBLE AIR CONNECTORS FOR ALL NEW DIFFUSERS. FLEXIBLE CONNECTORS SHALL NOT EXCEED FIVE (5) FEET.
- FLEXIBLE AIR DUCTS AND FLEXIBLE AIR CONNECTORS, BOTH METALLIC AND NONMETALLIC, SHALL BE TESTED IN ACCORDANCE WITH UL 181. SUCH DUCTS SHALL BE LISTED AND LABELED AS CLASS 0 OR CLASS 1.
- OUTSIDE AIR INTAKES SHALL BE A MINIMUM OF TEN (10) FEET FROM ANY EXHAUST VENT, FLUE VENT OR ANY OTHER MECHANICAL SOURCE OF CONTAMINATION AND TWELVE (12) FEET FROM ANY PLUMBING VENT.
- MECHANICAL CONTRACTOR SHALL PROVIDE BALANCING REPORTS BY A CERTIFIED BALANCER UPON COMPLETION OF PROJECT. PROVIDE INSPECTOR REPORTS PRIOR TO FINAL INSPECTION.
- MECHANICAL CONTRACTOR SHALL FIELD VERIFY LOCATION OF GAS METER.
- ALL THERMOSTATS SHALL BE MOUNTED IN ACCORDANCE WITH ADA REQUIREMENTS. WHERE THE THERMOSTAT IS ACCESSIBLE BY FRONTAL APPROACH ONLY, THEN THE MOUNTING HEIGHT OF THE THERMOSTAT SHALL BE 4'-0" A.F.F. WHERE THE THERMOSTAT IS ACCESSIBLE FROM A SIDE APPROACH, THEN THE MOUNTING HEIGHT OF THE THERMOSTAT SHALL BE 4'-6" A.F.F.
- ELECTRICAL CONTRACTOR SHALL WIRE ALL EQUIPMENT AND SHALL PROVIDE DISCONNECT SWITCHES, STARTERS AND/OR RELAYS AS REQUIRED.
- ELECTRICAL CONTRACTOR SHALL PROVIDE CONDUIT, UTILITY BOXES, AND WIRING FOR ALL THERMOSTATS. MECHANICAL CONTRACTOR SHALL FURNISH, MOUNT, AND TERMINATE THERMOSTATS ONLY.
- ELECTRICAL CONTRACTOR SHALL PROVIDE RETURN SMOKE DETECTORS IN SYSTEMS WITH A DESIGN CAPACITY OF GREATER THAN 2,000 CFM AND SUPPLY SMOKE DETECTORS IN SYSTEMS GREATER THAN 15,000 CFM. WIRE PER LOCAL CODE.
- ELECTRICAL CONTRACTOR SHALL PROVIDE A 120 VOLT, 15 OR 20 AMP GFCI CONVENIENCE OUTLET FOR ALL ROOFTOP, ATTIC SPACE, OR CRAWL SPACE HVAC EQUIPMENT. CONVENIENCE OUTLET SHALL BE ON THE SAME LEVEL AND WITHIN 25'-0" OF HVAC EQUIPMENT.
- EQUIPMENT AND APPLIANCES SHALL BE INSTALLED AS REQUIRED BY THE TERMS OF THEIR APPROVAL, IN ACCORDANCE WITH THE CONDITIONS OF THE LISTING, THE MANUFACTURER'S INSTALLATION INSTRUCTIONS AND THIS CODE. MANUFACTURER'S INSTALLATION INSTRUCTIONS SHALL BE AVAILABLE ON THE JOB SITE AT TIME OF INSPECTION, INCLUDING LISTING FOR OUTSIDE INSTALLATION WHEN APPLICABLE.
- SUBMIT UL LISTED FIRE STOPPING MATERIALS AND SYSTEMS WHERE FIRE RATED ASSEMBLIES ARE BREACHED.

ENERGY NOTES

- MINIMUM EQUIPMENT COOLING EFFICIENCY SHALL BE 11.0 EER.
- MOTORIZED DAMPERS SHALL BE INSTALLED ON ALL INTAKES AND EXHAUST OPENINGS UNLESS NOTED OTHERWISE.
- MAXIMUM FAN NAMEPLATE HORSEPOWER SHALL NOT EXCEED 1.1 HP/1000CFM.
- LOAD CALCULATIONS WERE BASED ON ASHRE 2009 FUNDAMENTALS
- ALL PROGRAMMABLE THERMOSTATS SHALL HAVE 5 DEGREE DEADBAND AND SHALL HAVE 7-DAY CLOCK, 2-HOUR MANUAL OVERRIDE, 10 HOUR BACKUP AND SETBACK CAPABLE OF 55 DEGREES HEATING AND 85 DEGREES COOLING. (EXCEPT CONTINUOUS OPERATING ZONES)
- DUCT INSULATION AS SPECIFIED WITH MINIMUM VALUES AS FOLLOWS:
 - R-8 SUPPLY AND RETURN DUCT INSULATION IN UNCONDITIONED SPACES.
 - R-8 SUPPLY AND RETURN DUCT INSULATION FOR EXTERIOR DUCTS.
 - R-3 SUPPLY AND RETURN DUCT INSULATION UNDERGROUND.
- ALL DUCTWORK SHALL BE SEALED PRESSURE SENSITIVE TAPE IS NOT USED AS THE PRIMARY SEALANT. LONGITUDINAL AND TRANSVERSE SEAMS FOR DUCTS IN UNCONDITIONED SPACES AND WALL PENETRATIONS. TRANSVERSE SEAMS ON BURIED DUCTS.

CONTRACTOR TO VERIFY FINAL TYPE, MODEL, AND QUANTITY OF ALL MECHANICAL EQUIPMENT PRIOR TO BID

MECHANICAL SYMBOLS

ALL SYMBOLS SHOWN MAY NOT APPEAR IN ALL DRAWINGS. SYMBOLS ARE SHOWN SCHEMATIC AND MAY NOT BE TO SCALE.

SYMBOL	DESCRIPTION
[Symbol]	DUCT
[Symbol]	SUPPLY DIFFUSER
[Symbol]	RETURN OR EXHAUST GRILLE
[Symbol]	SLOT DIFFUSER
[Symbol]	FLEXIBLE DUCT
[Symbol]	CO2 SENSOR
[Symbol]	THERMOSTAT
[Symbol]	EMS SENSOR
[Symbol]	HUMIDISTAT
[Symbol]	STATIC PRESSURE SENSOR
[Symbol]	SMOKE DETECTOR
[Symbol]	45° PRESSURE TAP WITH VOLUME DAMPER
[Symbol]	CONICAL TAP WITH VOLUME DAMPER
[Symbol]	CONICAL TAP WITHOUT VOLUME DAMPER
[Symbol]	MANUAL VOLUME DAMPER
[Symbol]	MOTORIZED DAMPER
[Symbol]	BAROMETRIC DAMPER
[Symbol]	FIRE/SMOKE DAMPER
[Symbol]	FIRE DAMPER
[Symbol]	SMOKE DAMPER
[Symbol]	CONDENSATE DRAIN
[Symbol]	DIRECTION OF SLOPE
[Symbol]	DIRECTION OF FLOW
[Symbol]	GATE VALVE
[Symbol]	BALL VALVE
[Symbol]	TEMPERATURE AND PRESSURE RELIEF VALVE
[Symbol]	PLUG VALVE/BALANCING COCK
[Symbol]	SOLENOID VALVE
[Symbol]	CHECK VALVE
[Symbol]	HYDRAULIC SHOCK ARRESTOR
[Symbol]	VALVE IN VERTICAL
[Symbol]	UNION
[Symbol]	VACUUM BREAKER
[Symbol]	GAS PRESSURE REGULATOR

MECHANICAL LEDGEND

EQUIPMENT	[Symbol]	MARK (SEE SCHEDULE)
AIR DEVICE	[Symbol]	EQUIPMENT NUMBER
	[Symbol]	TYPE-CFM-DEVICE TAG
	[Symbol]	NECK SIZE

MECHANICAL ABBREVIATIONS

AC	ABOVE CEILING	EUH	ELECTRIC UNIT HEATER
AFF	ABOVE FINISHED FLOOR	FPB	FAN POWERED BOX
AI	ANALOG INPUT	FPI	FINS PER INCH
AO	ANALOG OUTPUT	FPM	FEET PER MINUTE
BF	BELOW FLOOR	GC	GENERAL CONTRACTOR
BFC	BELOW FINISHED CEILING	GUH	GAS UNIT HEATER
BG	BELOW GRADE	LAT	LEAVING AIR TEMPERATURE
DB	DRY BULB	MVD	MANUAL VOLUME DAMPER
DI	DIGITAL INPUT	N	NEW
DO	DIGITAL OUTPUT	NTS	NOT TO SCALE
DS	DISCONNECT SWITCH	OPD	OPPOSED BLADE DAMPER
EDH	ELECTRIC DUCT HEATER	RA	RETURN AIR
EF	EXHAUST FAN	SA	SUPPLY AIR
		U.N.O.	UNLESS NOTED OTHERWISE
		VAV	VARIABLE AIR VOLUME
		WH	WATER HEATER

DESIGN CRITERIA

BASED ON ASHRAE HANDBOOK - 2009 FUNDAMENTALS
AURORA, ILLINOIS

OUTDOOR DESIGN CONDITION
1% COOLING: 89.0°/73.4°F DB/WB
99.6% HEATING: -4°F DB
INDOOR DESIGN CONDITION
SUMMER: 75°F DB/50% RH
WINTER: 70°F DB



DSC NORTH - SECOND FLOOR
77 S. BROADWAY
AURORA, IL 60505

MGH Consulting Engineers, LLC
LICENSE NO. 184.007392-0002
408 S. Highland Ave. Arlington Heights, IL 60005
mgh@mghe.com | Phone: 773.314.1919

MECHANICAL SCHEDULES, NOTES, & DETAILS

ISSUED:

- 3-19-19 ISSUED FOR REVIEW
- 4-8-19 ISSUED FOR PERMIT
- 4-23-19 ISSUED FOR PERMIT COMMENTS

M001

GENERAL NOTES

- FLEX DUCT SHALL NOT EXCEED 6'-0".
- CONTRACTOR IS RESPONSIBLE FOR ADJUSTING DIFFUSER AIRFLOWS AS SHOWN ON PLAN. PROVIDE A DETAILED TEST & BALANCE REPORT PRIOR TO CLOSEOUT.
- EXISTING HVAC EQUIPMENT, ROUTING LOCATION AND QUANTITY IS BASED ON LIMITED SURVEY. CONTRACTOR SHALL VERIFY THE EXACT LOCATIONS AND QUANTITIES.
- DIFFUSER NECK SIZES SHALL BE THE SAME AS ROUND DUCT THAT CONNECTS TO IT.
- CONTRACTOR SHALL VERIFY FOR EXACT LOCATION OF EXISTING BEAMS AND COORDINATE NEW DUCT SIZES/ROUTING ACCORDINGLY.
- COORDINATE LOCATION OF NEW FULL HEIGHT WALLS. ADJUST ASSOCIATED DUCTWORK, POWER, AND OTHER APPURTENANCES AS NECESSARY.

KEYED NOTES

- FURNISH AND INSTALL NEW ROOFTOP UNIT WITH GAS HEATING AND DX COOLING WITH ROOF CURB PER EQUIPMENT SCHEDULE. PROVIDE FULL SIZE SUPPLY AND RETURN INTO SPACE CEILING PLENUM. PROVIDE WITH TRAPPED CONDENSATE LINE, AND DIRECT IT TO NEAREST ROOF DRAIN. PROVIDE GAS CONNECTION TO RTU AS RECOMMENDED BY MANUFACTURER. PROVIDE WITH GAS COCK, UNION, & DIRT LEG.
- PROVIDE NEW OPEN ENDED 28"x14" INTERNALLY LINE RETURN DUCT. PROVIDE WIRE MESH SCREEN AT OPEN END OF DUCT.
- PROVIDE NEW RETURN GRILLE WITH 20"x10" DUCT BOOT FOR PLENUM RETURN SOUND ATTENUATION. DISCHARGE AIR INTO CEILING PLENUM.
- DUCT MOUNTED SMOKE DETECTOR ON RTU WITH 2,000 CFM OR GREATER SHALL BE FURNISHED AND INSTALLED BY FIRE ALARM CONTRACTOR. MOUNT IN RETURN AIR DUCT. DETECTOR TO SHUT DOWN UNIT UPON ALARM.
- EXISTING TRANSFER OPENING ABOVE CEILING TO REMAIN FOR PLENUM RETURN.
- REPLACE MISSING DUCTWORK WHERE REHEAT COILS HAVE BEEN REMOVED. NEW DUCT TO BE THE SAME SIZE AS EXISTING DUCTWORK.
- FURNISH AND INSTALL NEW COMPATIBLE 24V PROGRAMMABLE THERMOSTAT. INTERLOCK WITH ASSOCIATED ROOFTOP UNIT. MOUNT 56" A.F.F.
- FURNISH & INSTALL NEW ELECTRIC BASEBOARD FOR SUPPLEMENTAL HEAT. PROVIDE WITH FLOOR PEDESTALS AND FILLER SECTIONS AS REQUIRED. CONTROL WITH LOCAL THERMOSTAT. LOCATE WHERE SHOWN ON PLAN.
- FURNISH AND INSTALL NEW ELECTRIC WALL HEATER WITH INTEGRAL THERMOSTAT SET TO OPERATE AT 50°F. HEATER IS TO BE INSTALLED IN THIS LOCATION ON THE 1ST FLOOR.
- CONTRACTOR SHALL PROVIDE GUARDRAIL SINCE THERE ARE ELEMENTS OF THE HVAC LOCATED LESS THAN 10 FEET FROM THE EDGE OF THE BUILDING.

LEGEND

X	EXISTING TO REMAIN
N	NEW
XR	EXISTING RELOCATED
XRR	EXISTING TO BE RELOCATED
XO	EXISTING TO BE DEMOED
●	POINT OF DEMOLITION
●	POINT OF NEW CONNECTION

PLENUM SHALL BE EFFECTIVELY AND PERMANENTLY IDENTIFIED WITH SIGNAGE. THE SIGNAGE SHALL BE POSTED PRIOR TO THE FIRST ABOVE THE CEILING INSPECTION AND THE LETTERING SHALL NOT BE LESS THAN 1/2" IN HEIGHT AND BE PLACED ON EVERY WALL WITHIN THE PLENUM (OR SPACE/ROOM) AND REPEATED AT INTERVALS NOT EXCEEDING 30 FEET. THE SUGGESTING WORDING WILL BE OR BE SIMILAR TO - THIS CAVITY IS A MECHANICAL SYSTEM PLENUM. ALL MATERIALS WITHIN THIS PLENUM MUST BE NON-COMBUSTIBLES AND CONFORM TO IMC SECTION 602. CITY OF AURORA ORDINANCE No. 010-017.

ALL MATERIALS IN A RETURN AIR PLENUM MUST MEET THE REQUIREMENTS OF SECTION 602. (2015IECC). NEED TO INSPECT DUCT BEFORE IT IS INSULATED OR PAINTED R109.1.2 (2015 IRC) & SECTION 107 (2015IECC)

INSULATE SUPPLY & RETURN AIR DUCTS WITH A MINIMUM OF R-6 IN ALL UNCONDITIONED SPACES (EXAMPLE: DROPPED CEILING OR UNDERGROUND DUCTWORK) AND A MINIMUM OR R-12 WHEN LOCATED OUTSIDE (EXAMPLE: DUCTWORK ON ROOF) 2015IECC.

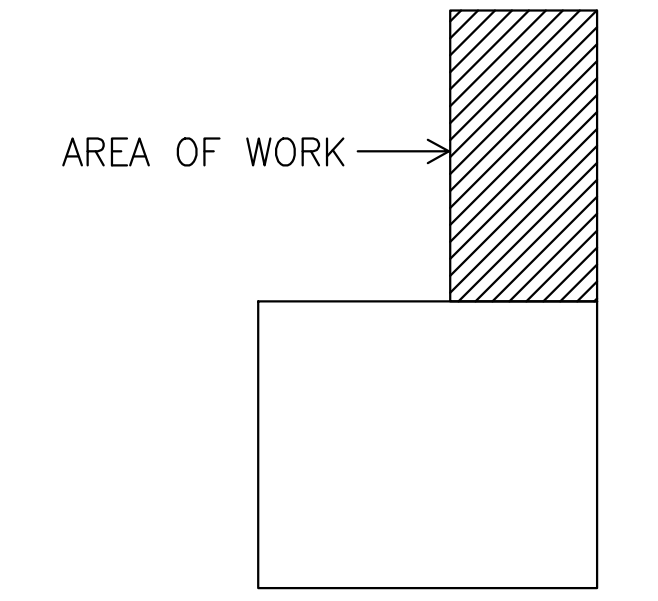

KEYPLAN
 N.T.S.

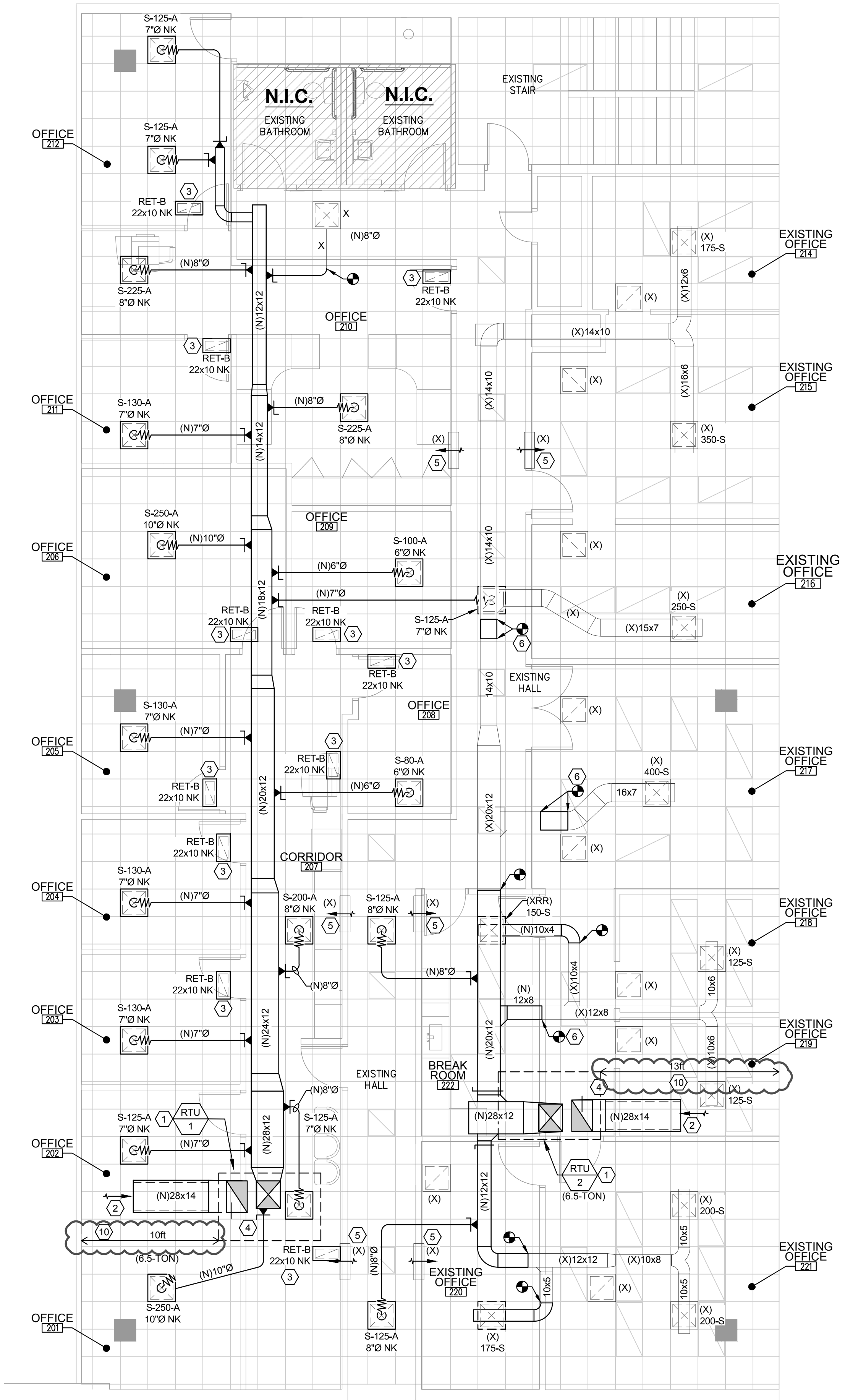

1 PARTIAL SECOND CEILING PLAN
 3/32" = 1'-0"
 0' 2' 5' 10' 15' 25'

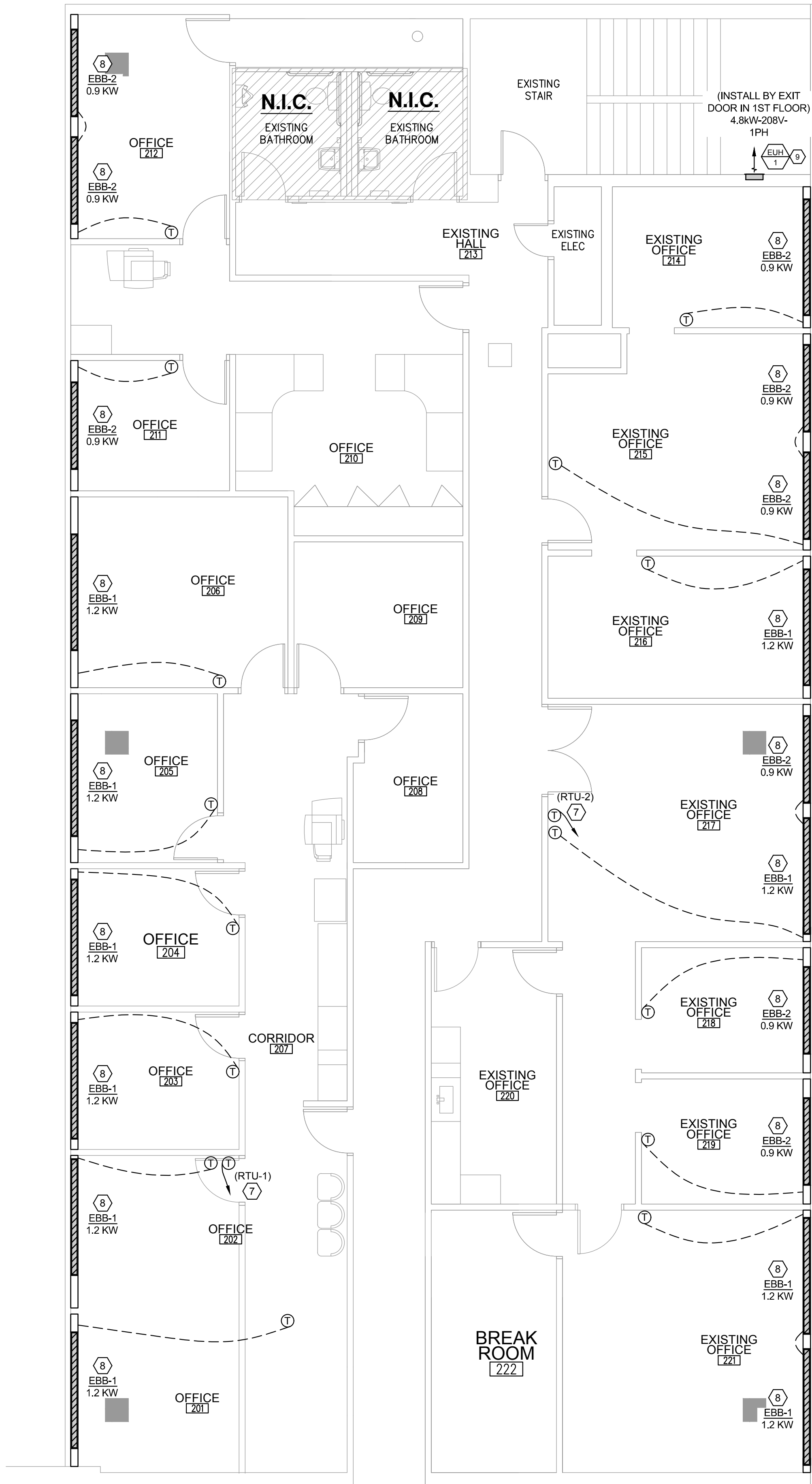

2 PARTIAL SECOND FLOOR PLAN
 3/16" = 1'-0"
 0' 1' 2' 4' 6' 10'

DEMO NOTES

- BECOME FAMILIAR WITH THE EXISTING CONDITIONS PRIOR TO SUBMITTING A COMPLETE BID WITHIN THE SCOPE OF THE PLANS AND SPECIFICATIONS. WHEN UNCLEAR, VERIFY THE EXTENT OF REMOVALS PRIOR TO BID. BRING TO THE ATTENTION OF THE ENGINEER ANY QUESTIONS IN REGARD TO THE EXTENT OF WORK OR ANY OTHER ISSUES RELATING TO THIS PROJECT.
- REMOVE ALL EXISTING MATERIAL AND EQUIPMENT INDICATED ON PLAN. THE OWNER SHALL HAVE FIRST RIGHTS TO ALL EQUIPMENT TO BE REMOVED. DISPOSE OF ALL EQUIPMENT AND MATERIAL THAT IS NOT WANTED BY OWNER IN AN APPROVED MANNER PER LOCAL AUTHORITY.
- WHEN THE EXTENT OF REMOVALS IS UNCLEAR, REQUEST CLARIFICATION FROM THE ENGINEER PRIOR TO COMMENCING WORK.
- WHEN MECHANICAL SYSTEMS ARE BEING REMODELED, COVER AND SEAL OPENINGS IN DUCTWORK, PIPING, OR MECHANICAL EQUIPMENT IN OPERATION THROUGH THE REMAINDER OF THE PROJECT.
- REPAIR ALL DAMAGE TO WALLS, CEILING, ETC. IN A WORKLIKE MANNER. SEAL ALL WALL AND CEILING OPENINGS WITH MATCHING MATERIAL.
- THE LOCATION OF EQUIPMENT SHOWN ON THE DRAWINGS IS BASED ON SITE OBSERVATIONS AND THE BEST AVAILABLE INFORMATION AT THE TIME OF DRAWING PREPARATION AND SOME DISCREPANCIES MAY EXIST. VERIFY EXACT LOCATIONS OF EQUIPMENT TO BE REMOVED IN THE FIELD AND REQUEST CLARIFICATION FROM THE ENGINEER WHEN LOCATION OR EXISTENCE DIFFERS FROM PLANS.
- COORDINATE WITH LANDLORD PRIOR TO REMOVING PIPING, DUCTWORK, EQUIPMENT, ETC... THAT MAY AFFECT OPERATIONS OUTSIDE OF TENANT SPACE.
- REMOVE ALL REMAINING UNUSED DUCTWORK, PIPING, ETC., NOT BEING REUSED BY TENANT. VERIFY THAT DUCTWORK OR PIPING IS NOT BEING USED OUTSIDE OF TENANT SPACE PRIOR TO REMOVAL.

DEMO KEYED NOTES

- REMOVE AND PROPERLY DISPOSE OF EXISTING HOT WATER BASEBOARD HEATER AND ALL RELATED CONTROLS, PIPING, ACCESSORIES, ETC. PATCH AND SEAL WEATHER PROOF/FIRE PROOF EXISTING OPENINGS NO LONGER REQUIRED AFTER REMOVAL OF EQUIPMENT
- REMOVE AND PROPERLY DISPOSE FOR UNUSED ROOF EXHAUST FAN AND ASSOCIATED CONTROLS, DUCTWORK, ETC... PROVIDE A WATER TIGHT SEAL AND CAP REMAINING CURB.
- REMOVE AND PROPERLY DISPOSE FOR UNUSED VENT. PROVIDE A WATER TIGHT SEAL AND CAP. (TYPICAL FOR ALL NOT LONGER REQUIRED VENT LOCATIONS IN AREA OF WORK)
- EXISTING TRANSFER OPENING ABOVE CEILING TO REMAIN FOR PLENUM RETURN.
- REMOVE AND PROPERLY DISPOSE OF EXISTING HOT WATER REHEAT COILS (BOXES) AND ALL RELATED CONTROLS, PIPING, ACCESSORIES, ETC. SEE NOTE #6 BELOW.
- REMOVE AND PROPERLY DISPOSE OF ALL UNUSED HVAC EQUIPMENT, DUCTWORK, CONTROLS, PIPING, ETC. PATCH AND SEAL WEATHER PROOF/FIRE PROOF EXISTING OPENINGS NO LONGER REQUIRED AFTER REMOVAL OF EQUIPMENT. REMOVE ALL HOT WATER BOXES AND PIPING IN THE WHOLE AREA OF WORK. SEE NOTE #5 ABOVE.

LEGEND	
X	EXISTING TO REMAIN
N	NEW
XR	EXISTING RELOCATED
XRR	EXISTING TO BE RELOCATED
XO	EXISTING TO BE DEMOED
●	POINT OF DEMOLITION
●	POINT OF NEW CONNECTION

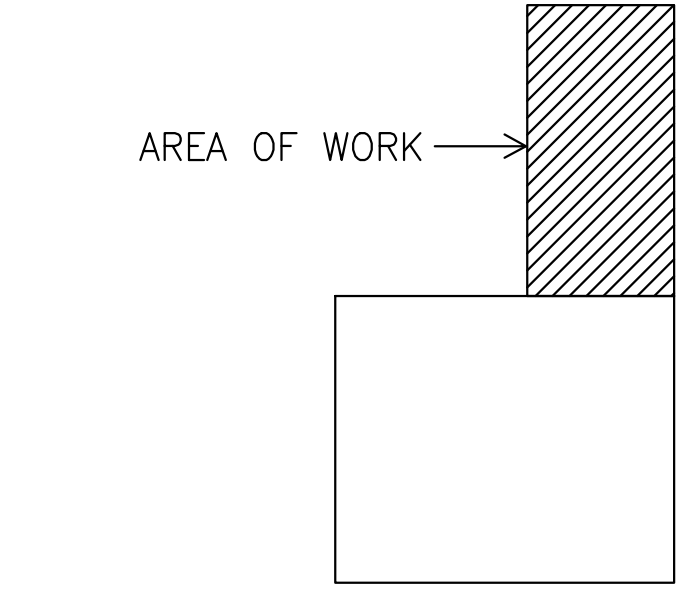

KEYPLAN
 N.T.S.

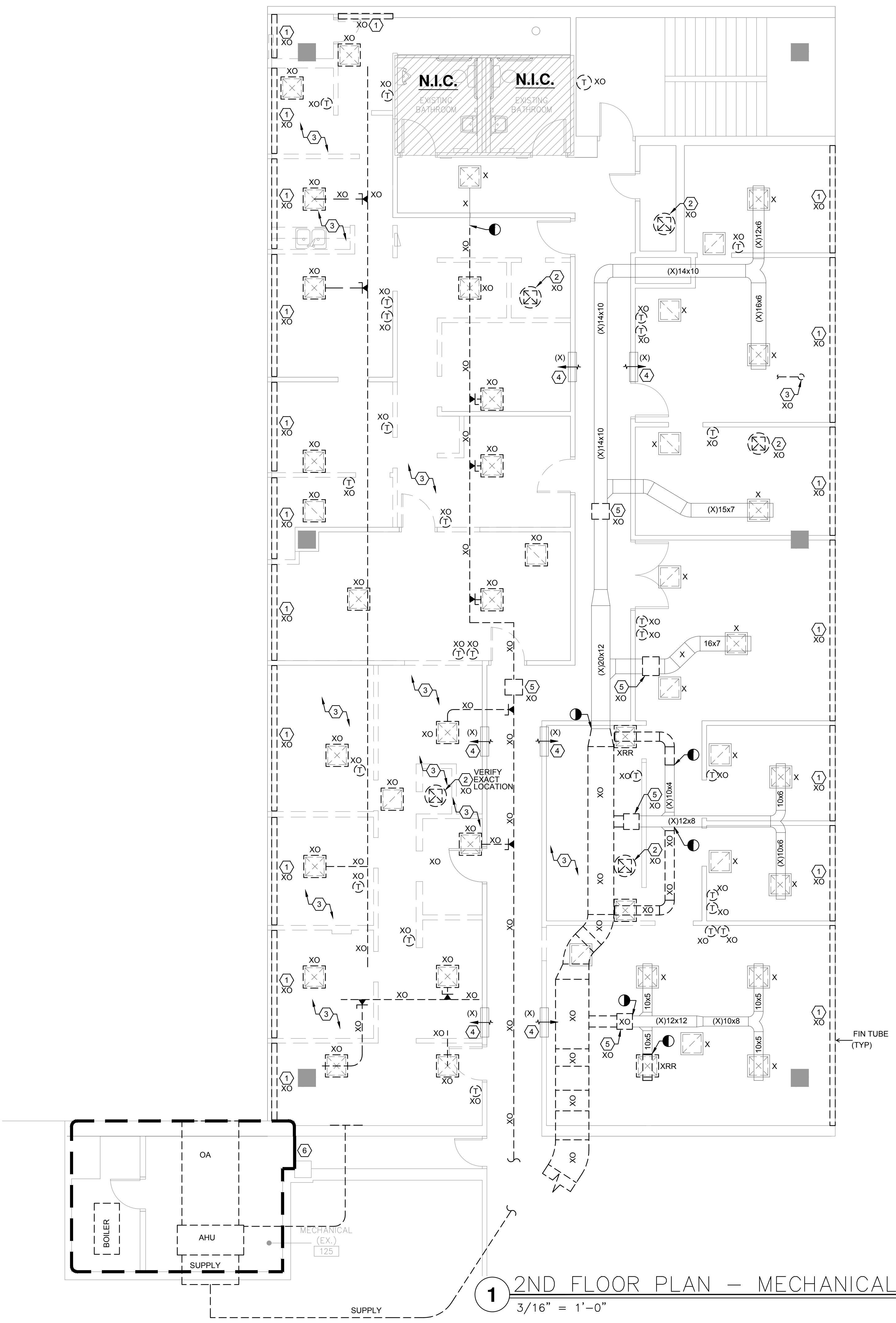

1 2ND FLOOR PLAN - MECHANICAL DEMOLITION
 3/16" = 1'-0"

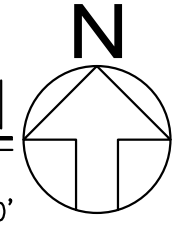
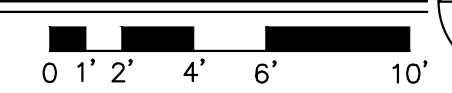

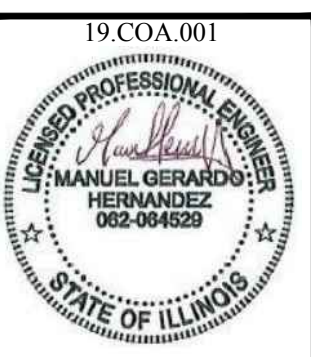

DSC NORTH - SECOND FLOOR
 77 S. BROADWAY
 AURORA, IL 60505

MGH Consulting Engineers, LLC
 LICENSE NO. 184.007392-0002
 408 S. Highland Ave. Arlington Heights, IL 60005
 mgharad@mgheengineering.com Phone: 773.314.1219

PLUMBING PLAN, NOTES, AND SCHEDULE

ISSUED:
 3-19-19
 ISSUED FOR REVIEW
 4-8-19
 ISSUED FOR PERMIT
 4-23-19
 ISSUED FOR PERMIT
 COMMENTS

P001

PLUMBING SPECIFICATIONS

STANDARDS AND CODES:

- A. GENERAL: THE WORK SHALL COMPLY WITH OR EXCEED THE REFERENCED STANDARDS AND CODES. ANY WORK WHICH CAN NOT MEET THE REFERENCED STANDARD AND CODES SHALL BE BROUGHT TO THE ATTENTION OF THE ENGINEER FOR HIS WRITTEN APPROVAL BEFORE PROCEEDING WITH THE WORK.
- B. CODES: THE WORK SHALL COMPLY WITH THE FOLLOWING CODES:
- 2014 ILLINOIS PLUMBING CODE
 - LOCAL GOVERNING BODIES HAVING JURISDICTION.
- C. STANDARDS: THE WORK SHALL COMPLY WITH THE FOLLOWING STANDARDS:
- ANSI AMERICAN NATIONAL STANDARDS INSTITUTE
 - ASSE AMERICAN SOCIETY OF SANITARY ENGINEERS
 - ASTM AMERICAN SOCIETY OF TESTING AND MATERIALS
 - AWWA AMERICAN WATER WORKS ASSOCIATION
 - CISPI CAST IRON SOIL PIPE INSTITUTE
 - NSF NATIONAL SANITATION FOUNDATION
 - UL UNDERWRITER LABORATORIES
 - ASME AMERICAN SOCIETY OF MECHANICAL ENGINEERS
 - NFPA NATIONAL FIRE PROTECTION ASSOCIATION
 - NEMA NATIONAL ELECTRICAL MANUFACTURES ASSOCIATION
 - CS COMMERCIAL STANDARDS

INSULATING ADAPTERS:

PROVIDE SWEAT-TO-SCREW INSULATING ADAPTERS AT JUNCTURE OF COPPER TO STEEL PIPE AND INSULATING BUSHINGS FOR FLANGED CONNECTIONS TO STEEL OR CAST IRON VALVES AND FITTINGS.

BALL VALVES:

A. SIZE, 2-1/2" AND SMALLER: 400LB. WOG, TWO-PIECE CAST BRONZE BODY, SCREWED OR SOLDERED ENDS, CHROME PLATED BRAS BALL, TEFLON BALL AND FLANGE SEALS, ROD SILICON BRASS STEM, TEFLON AND VICTON "O" RING STEM SEALS, ZINC PLATED CARBON STEEL HANDLE WITH VINYL GRIP AND BRASS HANDLE NUT.

APOLLO, STOCKHAM OR NIBCO

UNLESS OTHERWISE REQUIRED BY LOCAL CODE PIPING MATERIAL SHALL BE AS FOLLOWS:

VENT, SOIL, AND WASTE & STORM - ABOVE GROUND: 2-1/2" AND LARGER: TAR COATED SERVICE WEIGHT CAST IRON, BELL & SPIGOT CAST IRON DRAINAGE FITTINGS WITH LEAD & OAKUM CAULK, 2" AND SMALLER: STANDARD WEIGHT THREADED GALVANIZED STEEL PIPE, PVC MAY BE USED WHERE ALLOWABLE BY CODE.

DOMESTIC WATER - ABOVE GROUND INSIDE BUILDING: SEAMLESS TYPE "L" COPPER WITH WROUGHT COPPER FITTINGS SOLDERED. SOLDER SHALL CONFORM TO LOCAL CODE REQUIREMENTS AND ASTM B32-LATEST REVISION. BELOW GRADE INSIDE BUILDING: ANNEALED TYPE "K" COPPER.

VALVES - BALL VALVES FOR SHUT-OFF SHALL BE AS MANUFACTURED BY NIBCO: 880, HAMMOND: 8801.

INSULATION SHALL BE PROVIDED AS FOLLOWS:

DOMESTIC COLD WATER - ABOVE GRADE: LIGHT DENSITY, FIBERGLASS PIPE INSULATION, 1/2" THICK, WITH VAPOR BARRIER JACKET.

DOMESTIC HOT WATER - ABOVE GRADE: LIGHT DENSITY, FIBERGLASS PIPE INSULATION, 1" THICK, WITH GLASS CLOTH JACKET.

AT CONTRACTOR'S OPTION FIBERGLASS SNAP ON INSULATION WITH FOAM VAPOR BARRIER MAY BE SUBSTITUTED FOR ABOVE.

DOMESTIC HOT AND COLD WATER PIPING IN PIPE CHASSES - SHALL BE INSULATED WITH 1/2" THICK, 3-1/2 LB. DENSITY FIBERGLASS WITH ALL PURPOSE VAPOR BARRIER JACKET.

SUBMITTALS:

- A. SHOP DRAWINGS: SUBMIT FOR ENGINEER'S REVIEW, ONE SEPIA AND TWO PRINTS OF ALL PIPING LAYOUTS AND DETAILS. DRAWINGS SHALL CONSIST OF THE FOLLOWING:
1. PIPING (FLOOR) LAYOUTS IN PLAN DRAWING TO A MINIMUM SCALE OF 1/8" = 1'-0" WITH EQUIPMENT ROOM ARRANGEMENTS AND SITE REINFORCED CONCRETE STRUCTURES DRAWN TO A MINIMUM SCALE OF 1/4" = 1'-0".
 2. SLEEVE PLACEMENT LOCATION, MINIMUM SCALE OF 1/8" = 1'-0" IN PLAN AND ELEVATION DIMENSION FROM CENTERLINE OF BUILDING COLUMN OR FACE OF MAJOR STRUCTURAL ELEMENTS.

- B. RECORD DOCUMENTS: SUBMIT THE FOLLOWING FOR ENGINEER'S INFORMATION. FURNISHED DRAWINGS TEST AND INSPECTION REPORTS WITNESSED BY THE OWNER'S REPRESENTATIVE AND OTHER AUTHORITY OF JURISDICTION, AND RECORD DRAWINGS INDICATING THE WORK AS ACTUALLY CONSTRUCTED.

RECORD DRAWINGS:

MAINTAIN A COMPLETE AND ACCURATE RECORD OF ALL CHANGES OR DEVIATIONS TO THE CONTRACT DOCUMENTS AND SHOP DRAWINGS IN THE CONTRACTOR'S FIELD OFFICE. SUCH RECORD COPY SHALL INDICATE THE WORK AS ACTUALLY CONSTRUCTED AND BE AVAILABLE FOR ARCHITECT AND OWNER REVIEW. REPRODUCIBLE DRAWING BACKGROUND SHALL BE FURNISHED TO THE CONTRACTOR BY THE ARCHITECT. TURN OVER AS-BUILT DRAWING TO BUILDING MANAGEMENT/BUILDING ENGINEER UPON COMPLETION OF PROJECT.

- C. OPERATION AND MAINTENANCE MANUALS: SUBMIT FOR OWNER DOCUMENTATION. FURNISH (3) BOUND COPIES OF DATA COVERING MODEL, RATINGS AND CAPACITIES FOR EACH ITEM OF EQUIPMENT OR DEVICE. IF THE LANGUAGE OR INTENT OF ANY ACCEPTANCE DOCUMENT VOIDS, THE WARRANTY PERIOD OR TERMS OF THE FINAL ACCEPTANCE AS STIPULATED IN THE CONTRACT DOCUMENTS, OPERATION AND MAINTENANCE MANUALS FOR THE PIPING BEING ACCEPTED FOR PURPOSES OF BENEFICIAL OCCUPANCY SHALL BE GIVEN TO THE OWNER'S REPRESENTATIVE AT SUCH ACCEPTANCE.

TESTING - POTABLE WATER:

- A. AFTER PORTIONS OF THE POTABLE WATER SYSTEM HAS BEEN COMPLETED, THE WORK SHALL BE HYDROSTATICALLY TESTED IN THE PRESENT OF THE ARCHITECT'S AND OWNER'S REPRESENTATIVES AND OTHER AUTHORITIES OF JURISDICTION. FIVE DAYS NOTICE OF THE TEST SHALL BE GIVEN TO THE ARCHITECT AND OWNER. FURNISH ALL PUMPS, GAGES, INSTRUMENTS, TEST EQUIPMENT AND PERSONNEL REQUIRED FOR THESE TESTS AND MAKE ALL PROVISIONS FOR REMOVAL OF TEST EQUIPMENT.
- B. VENT ALL AIR FROM THE SYSTEM FOR HYDROSTATIC TESTING.
- C. IN THE CASE OF THE HYDROSTATIC TEST WITH WATER, THE TEST PRESSURE SHALL BE 100 PSIG OR 1-1/2" X MAXIMUM WORKING PRESSURE, WHICHEVER IS THE GREATER. TEST PRESSURE SHALL BE HELD WITH NO NOTICEABLE LOSS IN PRESSURE WHICH ALL JOINTS ARE VISUALLY INSPECTED FOR LEAKS. WATER TEMPERATURE SHALL NOT EXCEED 100 DEGREE F.

FLUSHING:

- A. BUILDING DOMESTIC COLD WATER AND HOT WATER PIPING SHALL BE CLEANED AND FLUSHED SO AS TO BE FREE OF ALL THREAD CUTTING OIL, THREAD CHIPS, SOLDER RESIDUE, SHAVINGS AND OTHER FOREIGN MATTER. AFTER CLEANING AND FLUSHING, THE PIPING SYSTEM SHALL BE DISINFECTED.

1. REMOVE SCREENS FROM ALL IN-LINE STRAINERS EXCEPT THOSE AT PUMP STATION.
2. OPEN ALL CONTROL VALVES TO FULLY OPEN POSITION.
3. FLUSH TO OBTAIN FLOW OF CLEAN WATER.

DISINFECTION:

- A. DISINFECT THE DOMESTIC WATER SYSTEM TO THE OWNER'S SATISFACTION, WITH BLEACH OR CHLORINE GAS. AFTER DISINFECTING, FLUSH THE SYSTEM AS HEREIN BEFORE DESCRIBED UNDER FLUSHING.
1. PROVIDE NIPPLES AND VALVES AS REQUIRED TO INTRODUCE DISINFECTANT AND WATER.
 2. FILL THE SYSTEM UNIFORMLY WITH A DISINFECTION SOLUTION OF 100-PPM AVAILABLE CHLORINE. THE DISINFECTANT SHALL BE RETAINED ON LESS THAN 24 HOURS. AS AN ALTERNATE, A SOLUTION OF 300 PPM HELD FOR 3 HOURS IS ALSO ACCEPTABLE. AFTER THE HOLDING PERIOD, A TEST FOR RESIDUAL CHLORINE SHALL BE MADE. IF NONE IS FOUND, THE SYSTEM SHALL BE DRAINED AND THE DISINFECTION PROCEDURE REPEATED. WHEN A POSITIVE RESIDUAL CHLORINE TEST IS ACCOMPLISHED, THE SYSTEM SHALL BE FLUSHED WITH POTABLE WATER AND PUT INTO OPERATION.

PLUMBING FIXTURE SCHEDULE

DESIG.	COMPONENT	QTY	MANUFACTURER/MODEL	REMARKS
SK-1	PANTRY SINK	1	ELKAY #ELUHD211555	UNDERMOUNT ADA STAINLESS STEEL SINK (18 1/2" L x 23 1/2" W x 5 3/8" D) W/ "KOHLER" #K-7505 FAUCET WITH PULL-OUT SPRAYER, STAINLESS STEEL FINISH (WATER SENSE). COORDINATE INSTALLATION HARDWARE WITH MANUFACTURER AND MILLWORK. PROVIDE TEMPLATE FOR MILLWORK, GRID/OFFSET DRAIN, STAINLESS CHROME PLATED SUPPLY STOPS, CAST BRASS P-TRAP, "MCGUIRE" PRO-WRAP FOR UNDER COUNTER PIPING, & THERMOSTATIC MIXING VALVE (TMV) SET TO 105°F.
HD-1	HUB DRAIN	1	JAY R. SMITH #9740	INDIRECT WASTE RECEPTOR; ROUGH FINISH STAINLESS STEEL BODY WITH ALUMINUM DOME BOTTOM STRAINER.
EW-1	ELECTRIC WATER HEATER	1	EEMAX #EMT6 MINI-TANK SERIES	6-GAL ELECTRIC WATER HEATER. 1.44 KW HEATING ELEMENT. UNIT SHALL BE GLASS LINED WITH A SINGLE WELD DESIGN. WATER CONNECTIONS AND SUPPLIED T&P VALVE TO BE LOCATED ON TOP OF THE UNIT. UNIT SHALL HAVE AN STATUS INDICATOR LIGHT WITH ADJUSTABLE THERMOSTAT SET TO 105°F. ELECTRICAL: 120V/1PH, 12 AMPS

GENERAL NOTES

1. PLUMBING CONTRACTOR TO VERIFY ALL EXISTING WASTE, VENT AND WATER SUPPLY PIPING WHERE NEW CONNECTIONS ARE TO BE MADE PRIOR TO BID. VERIFY EXACT SIZE, LOCATION, INVERT, CONDITION AND REQUIREMENTS IN FIELD. REPORT ANY MAJOR DISCREPANCIES TO ARCHITECT/ENGINEER IMMEDIATELY.
2. PROVIDE DI-ELECTRIC UNIONS, COUPLINGS, ADAPTORS OR FLANGES AT ALL TRANSITIONS OF FERROUS PIPING TO NON-FERROUS PIPING.
3. PROVIDE 12" AIR CHAMBER AT ALL FIXTURES.
4. PROVIDE THERMOSTATIC MIXING VALVE AT LAVS AND SINKS. SET AT MAXIMUM 105°F.

KEY NOTES

1. FURNISH AND INSTALL NEW ADA COMPLIANT SINK (SK-1) AS SCHEDULED. CONNECT NEW 1/2" CW/HW, 2" SANITARY, AND 1 1/2" VENT.
2. FURNISH AND INSTALL HUB DRAIN SINK UNDER CABINET FOR WATER T&P DISCHARGE. CONNECT NEW 2" SANITARY, ROUTE NEW 1 1/2" VENT UP IN WALL AND CONNECT TO VENT MAIN.
3. FURNISH & INSTALL NEW UNDER COUNTER 6-GALLON ELECTRIC WATER HEATER (EW-1) AS SCHEDULED. PROVIDE DRIP PAN, DISCHARGE T&P AND DRIP PAN DRAIN TO NEAREST OPEN SITE DRAIN (HD-1).

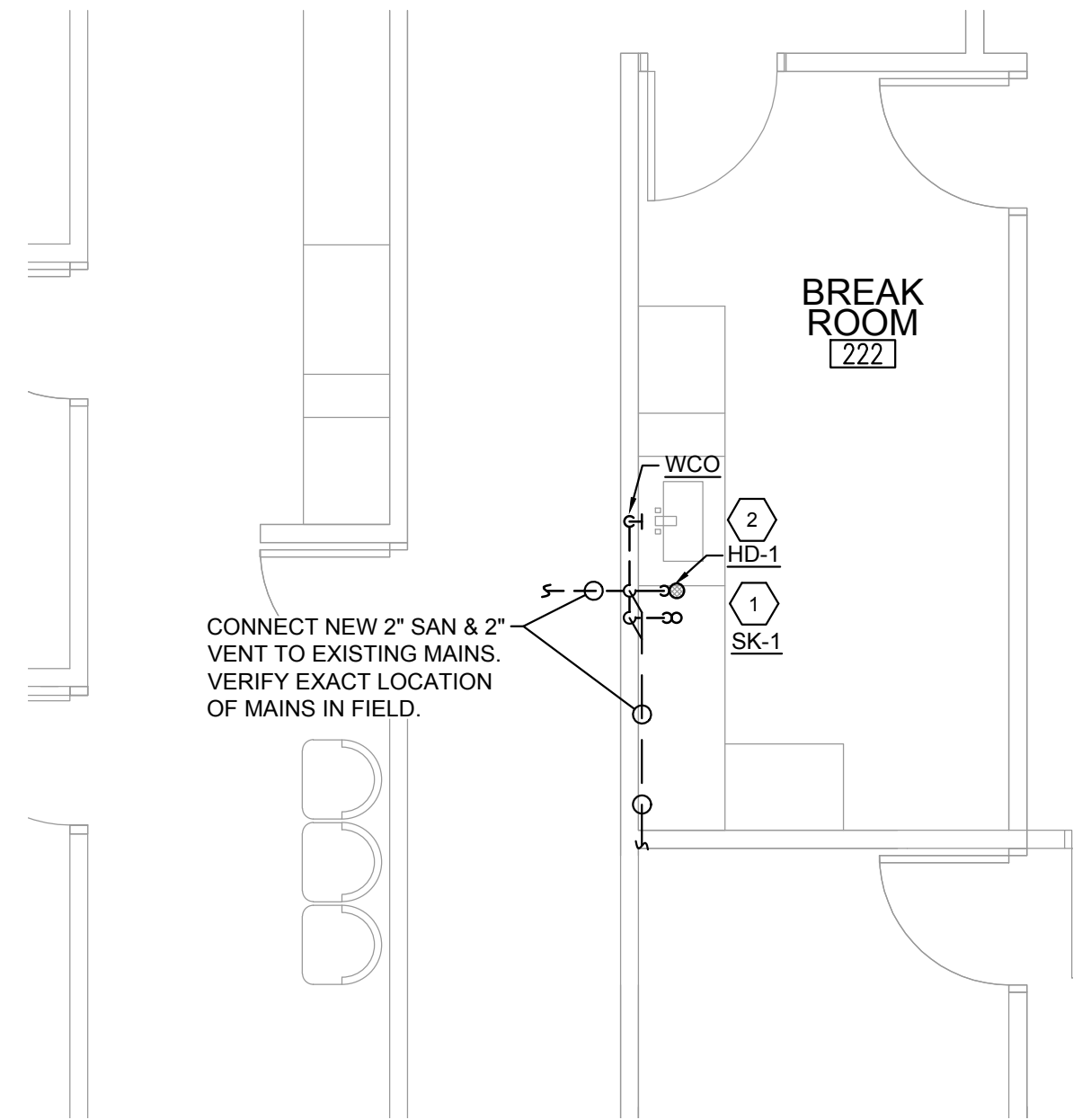

1 ENLARGED SAN & VENT PLAN
 1/4" = 1'-0" PLUMBING

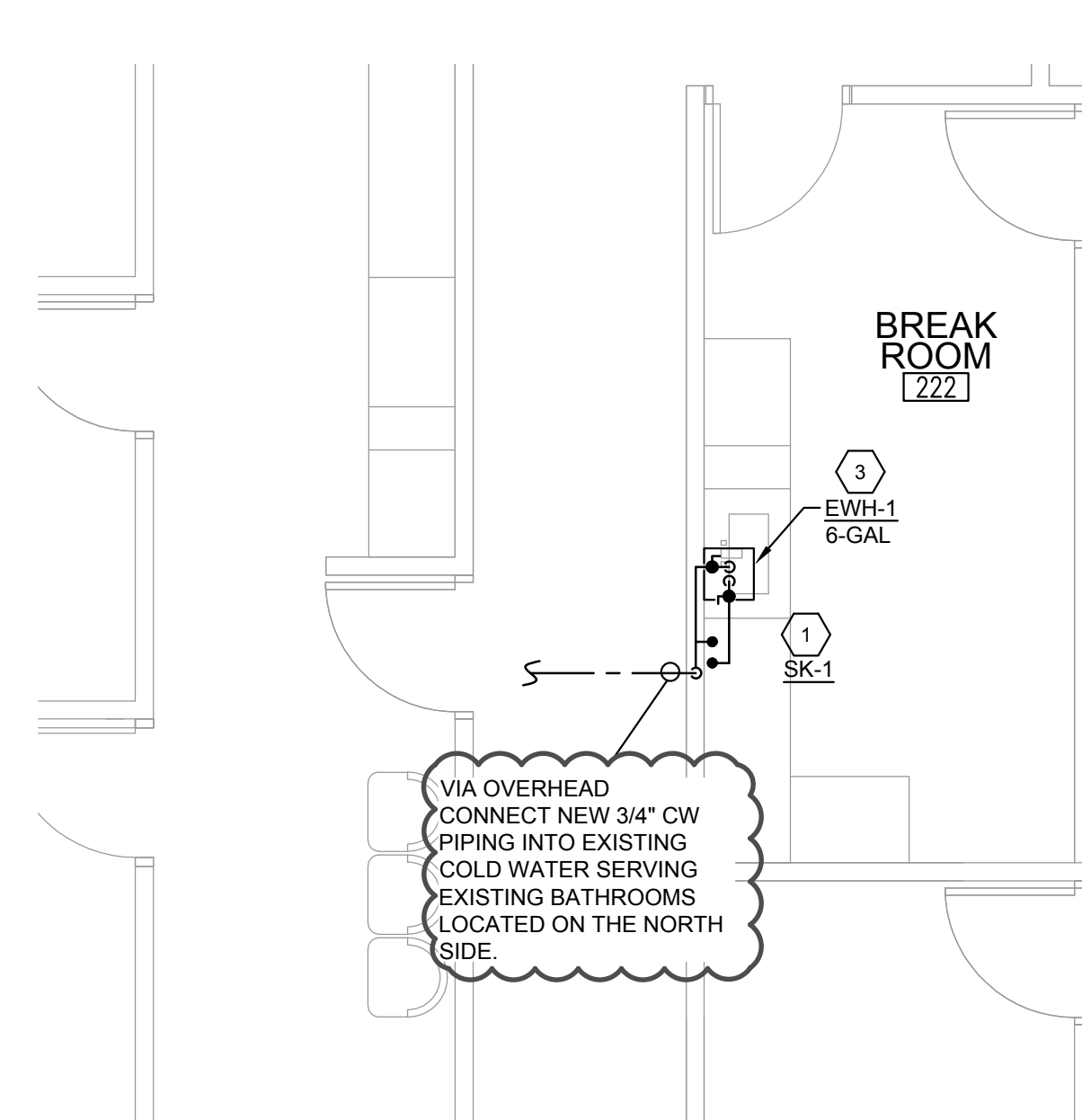

2 ENLARGED DOMESTIC WATER PLAN
 1/4" = 1'-0" PLUMBING

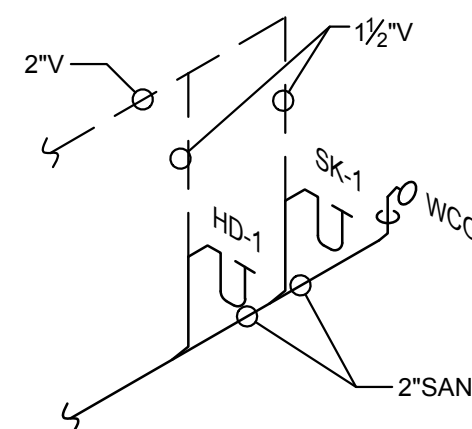

SAN & VENT RISER DIAGRAM

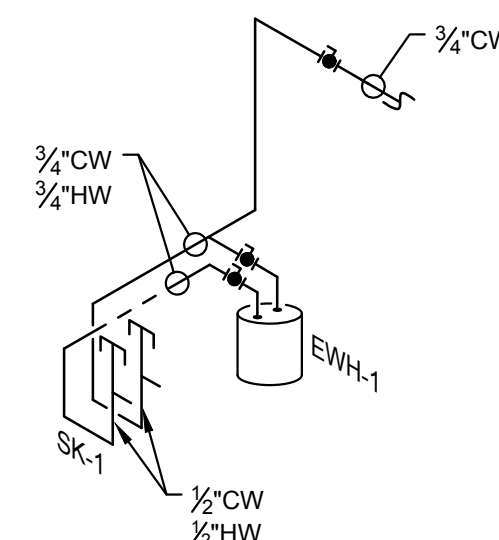

DOMESTIC WATER RISER DIAGRAM

PLUMBING SYMBOLS

- NOT ALL SYMBOLS MAY APPLY
- EXISTING COLD WATER PIPING
 - EXISTING HOT WATER PIPING
 - EXISTING HOT WATER RETURN PIPING
 - EXISTING UNDERGROUND SEWER
 - EXISTING SUSPENDED SEWER
 - EXISTING VENT PIPING
 - COLD WATER PIPING (INSULATED)
 - HOT WATER PIPING (INSULATED)
 - HOT WATER RETURN PIPING (INSULATED)
 - UNDERGROUND SEWER
 - SUSPENDED SEWER
 - VENT PIPING
 - UNION
 - PIPE CAPPED
 - PIPE CONTINUATION
 - PIPE DROP (ELBOW)
 - PIPE UP/RISER (ELBOW)
 - P-TRAP
 - PIPE UP/RISER (TEE)
 - PIPE DROP (TEE)
 - CLEANOUT PLUG(S) IOUX CHIEF #875-2P/877/878)
 - WALL CLEANOUT PLUG(S) IOUX CHIEF #870/873/877/878)
 - FCO FLOOR CLEANOUT(S) IOUX CHIEF #834)
 - YCO YARD CLEANOUT (SIOUX CHIEF #851)
 - FD-1 FLOOR DRAIN (FINISHED FLR AREA) (SIOUX CHIEF #832 OR 833)
 - FD-2 FLOOR DRAIN (NON-FINISHED FLR AREA) (SIOUX CHIEF #860)
 - FD-3 FLOOR FUNNEL DRAIN(S) SAME AS FD-1 W/ SIOUX CHIEF #863-FN)
 - OSD OPEN SITE DRAIN (PROVIDE FUNNEL AS REQ'D)
 - AD-1 AREA DRAIN (SIOUX CHIEF)
 - FS-1 FLOOR SINK (SIOUX CHIEF #861 W/ NICKEL BRONZE 1/2 GRATE)
 - TD-1 PRE-SLOPED HDPE TRENCH DRAIN (SIOUX CHIEF #865 SERIES) W/ D.I. GRATE
 - RD-1 ROOF DRAIN (SIOUX CHIEF #868-U-S-E)
 - ORD-1 OVERFLOW ROOF DRAIN(S) IOUX CHIEF #868-U-S-E-STP-2) WITH STANDPIPE
 - AP DOWNSPOUT NOZZLE (SIOUX CHIEF #868-N SERIES) FURNISH BIRD SCREEN & SPLASH BLOCK AS REQ'D
 - ACCESS PANEL (SIOUX CHIEF #971 SERIES)
 - GV GATE VALVE (NIBCO OR EQUAL)
 - RP-1 IN-LINE RECIRCULATING PUMP (MFG'RD BY TACO)
 - BV BALL VALVE (NIBCO OR EQUAL)
 - HWR BALANCING TRIM CONSISTS OF:
 - CS CIRCUIT SETTER (NEXUS VALVE "ULTRA MB" #MBNL)
 - STR STRAINER (NIBCO OR EQUAL)
 - CV CHECK VALVE (NIBCO OR EQUAL)
 - BFP BACKFLOW PREVENTER (WATTS #LF909-AG-S)
 - FPWH-1 FROSTPROOF WALL HYDRANT (PRIER #C-634)
 - HB-1 HOSE BIBB W/ VB (PRIER #C-258)
 - FPRH-1 FROST PROOF ROOF HYDRANT W/ BRACKET (PRIER #P-RH2)
 - BFP DUAL CHECK BACKFLOW PREVENTERS - USE WATTS #7 FOR ICE & COFFEE MAKERS - USE WATTS #SD-3 FOR CARBONATORS/SODA DISP. (S.S. W/ ATMOSPHERIC PORT)
 - NEW CONNECT TO EXISTING
 - SAN INDICATES SANITARY SEWER
 - ST INDICATES STORM SEWER
 - (EX) INDICATES EXISTING
 - AC ABOVE CEILING
 - UV UNDERGROUND VENT
 - GW INDICATES GREASE WASTE SEWER

PIPE MATERIALS

CONDITION/LOCATION	MATERIAL TYPE
ABOVE GROUND WATER	TYPE "L" COPPER
BELOW GROUND WATER	TYPE "K" COPPER
WASTE (UNDER 2")	SCH. 40 PVC PLASTIC
WASTE (ABOVE 2")	SCH. 40 PVC PLASTIC
VENT (UNDER 2")	SCH. 40 PVC PLASTIC
VENT (ABOVE 2")	SCH. 40 PVC PLASTIC
GAS PIPING	SCH. 40 WROUGHT IRON
CONDENSATE PIPING	SCHED. 40 PVC PLASTIC

SLOPE OF HORIZ. DRAINS

SIZE (INCHES)	MINIMUM SLOPE (INCH / FOOT)
2-1/2 OR LESS	1/4
3 TO 6	1/8
8 OR LARGER	1/16

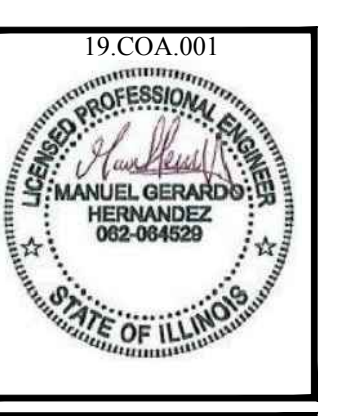

DSC NORTH - SECOND FLOOR
77 S. BROADWAY
AURORA, IL 60505

MGH Consulting Engineers, LLC
ENGINEERING
LICENSE NO. 184.007392-0002
409 S. Highland Ave. Arlington Heights, IL 60005
mgh@mghe.com Phone: 773.314.7819

PLUMBING DEMOLITION PLAN

ISSUED:
3-19-19
ISSUED FOR REVIEW
4-8-19
ISSUED FOR PERMIT
4-23-19
ISSUED FOR PERMIT COMMENTS

PD201

DEMOLITION NOTES

1. THE PLUMBING CONTRACTOR SHALL INSPECT THE JOB SITE TO ASCERTAIN THE EXTENT OF THE DEMOLITION NECESSARY AND INCLUDE ALL ITEMS IN THE BID. REFER TO ARCHITECTURAL DRAWINGS.
2. THE PLUMBING CONTRACTOR SHALL REMOVE AND PROPERLY DISPOSE OF ALL UNUSED FIXTURES, EQUIPMENT, SUPPORTS, ETC...
3. REMOVE AND PROPERLY DISPOSE OF ALL UNUSED PIPING ALONG WITH ITS INSULATION, HANGERS, SUPPORTS, VALVES, AND FITTINGS. CAP DEMOED PIPES AT MAIN.
4. REMOVE ALL UNUSED PIPING OR PLUMBING MATERIALS IN THE SPACE.

DEMOLITION KEYED NOTES

- 1 REMOVE EXISTING PLUMBING FIXTURE(S), ALL ASSOCIATED PIPING INCLUDING BUT NOT LIMITED TO WATER, WASTE & VENT AND ACCESSORIES. CAP PIPES AT MAIN. PATCH ALL FLOOR AND ROOF OPENINGS WEATHER / FIRE PROOF.
- 2 PLUMBING CONTRACTOR SHALL FURNISH AND INSTALL NEW HEAT TAPE ALONG THE EXISTING 3" SANITARY PIPE LOCATED IN THE BRIDGE AREA IN UNCONDITIONED AREA. HEAT TAPE SHALL BE LISTED FOR PLUMBING SYSTEMS APPLICATIONS IN FREEZING WEATHER CONDITIONS. HEAT TAPE SHALL BE WRAPPED AROUND THE EXISTING SANITARY PIPE(S) TO AVOID FREEZING OF THE WASTE LIQUID INSIDE THE PIPES. PLUMBING CONTRACTOR SHALL COORDINATE WITH THE ELECTRICAL CONTRACTOR FOR EXACT HEAT TAPE POINT OF CONNECTION REQUIREMENTS AND POWER REQUIREMENTS. REFER TO ELECTRICAL DRAWING, SHEET E301, PANEL PPB SCHEDULE, CIRCUITS 27,29,31,33 FOR ADDITIONAL INFORMATION.

LEGEND	
X	EXISTING TO REMAIN
N	NEW
XR	EXISTING RELOCATED
XRR	EXISTING TO BE RELOCATED
XO	EXISTING TO BE DEMOED
●	POINT OF DEMOLITION
⊕	POINT OF NEW CONNECTION

DEAD ENDS IN WASTE PIPING OVER 10 FEET HORIZONTALLY OR 2 FEET ABOVE THE FLOOR ARE NOT PERMITTED PER 2014 STATE OF ILLINOIS PLUMBING CODE, SECTION 890.1320(d)

UNUSED SECTIONS OF WATER PIPING OVER 2 FT IN LENGTH FROM A CIRCULATED WATER LINE IS CONSIDERED A DEAD END AND ARE NOT PERMITTED PER 2014 STATE OF ILLINOIS PLUMBING CODE, SECTION 890.1200(c)

● Cold Water Supply and Shut Off Valve locations for Bid Alternate 2B

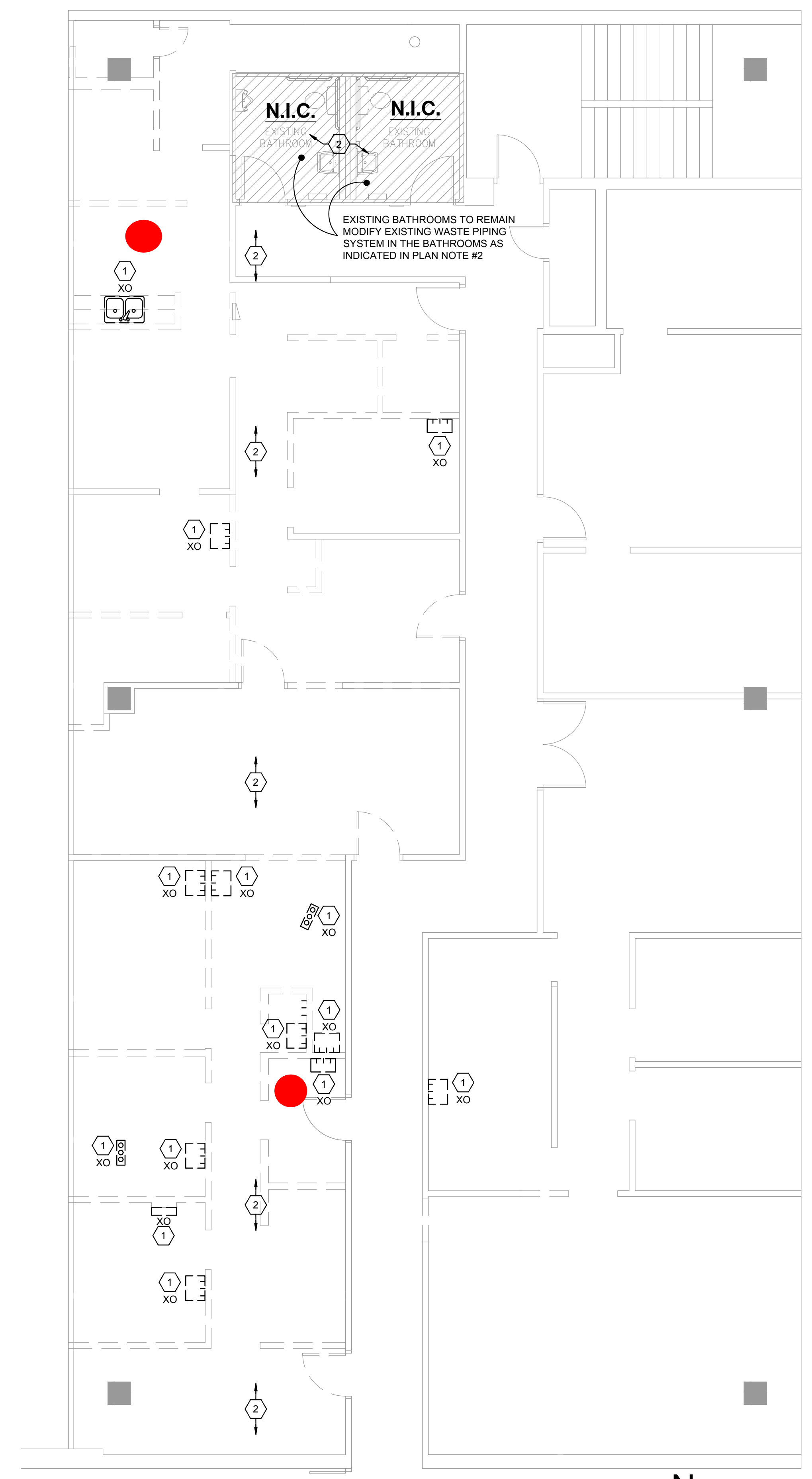
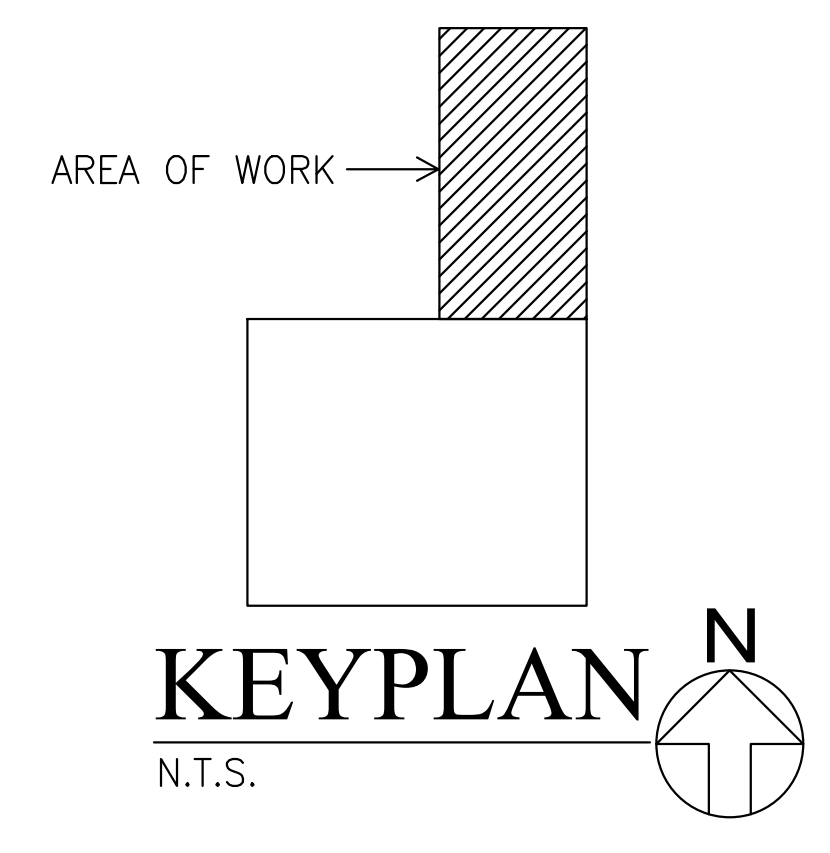

1 PLUMBING DEMOLITION PLAN
3/16" = 1'-0"
0' 1' 2' 4' 6' 10'

