

LEGEND

- ⊕ POWER POLE
- ⊗ LIGHT POLE
- MANHOLE
- ⊕ STORM INLET
- ⊕ WV WATER VALVE
- ⊕ GV GAS VALVE
- ⊕ FIRE HYDRANT
- ⊕ ELECTRIC TRANSFORMER
- ⊕ TELEPHONE PEDESTAL
- GUY WIRE
- GRD GUARD POST
- R BAR REBAR
- + c.c. CHISELED CROSS
- EMH ELECTRIC MANHOLE
- ⊕ CATCH BASIN
- ⊕ WATER VAULT
- x GRT GRATE
- ⊕ HANDHOLE
- ⊕ 2" DECIDUOUS TREE
- ⊕ 2" CONIFEROUS TREE
- ⊕ BUSH
- ⊕ SIGN
- ⊕ HEDGE ROW
- ⊕ WROUGHT IRON FENCE
- ⊕ WOOD FENCE
- ⊕ BURIED CABLE TV
- ⊕ BURIED ELECTRIC LINE
- ⊕ OVERHEAD ELECTRIC LINE
- ⊕ BURIED FIBER OPTIC
- ⊕ BURIED GAS MAIN
- ⊕ BURIED SANITARY SEWER
- ⊕ BURIED STORM SEWER
- ⊕ BURIED TELEPHONE LINE
- ⊕ BURIED WATER MAIN

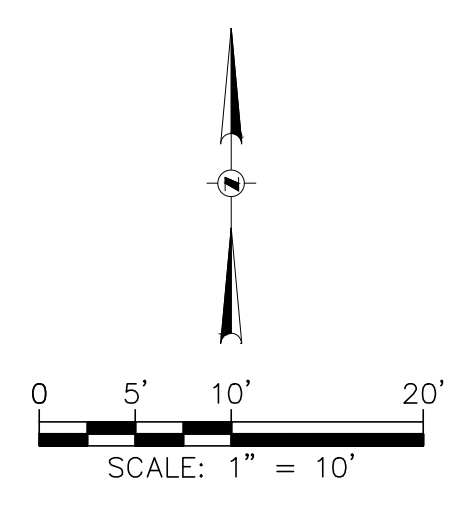

STRUCTURE TABLE

- | | | | |
|---|--|---|--|
| 1 | STORM MANHOLE
RIM EL. 697.72
12" NE. 690.3
15" S. I.E. 690.2 | 6 | SANITARY MANHOLE
RIM EL. 691.15
6" SW. I.E. 682.9
6" S. I.E. 682.8
6" N. I.E. 682.7 |
| 2 | CATCH BASIN
RIM EL. 697.45
12" N. I.E. 690.9
12" SW. I.E. 690.8 | 7 | SANITARY MANHOLE
RIM EL. 690.36
6" SE. I.E. 685.9
6" SW. I.E. 685.4
6" S. I.E. 682.4
15" NE. I.E. 682.7 |
| 3 | CATCH BASIN
RIM EL. 695.79
12" NE. I.E. 691.1
12" SW. I.E. 691.0 | 8 | STORM INLET
RIM EL. 690.21
6" NE. I.E. 687.1 |
| 4 | STORM INLET
RIM EL. 695.79
12" SE. I.E. 691.4
12" SW. I.E. 691.4 | 9 | WATER VAULT
RIM EL. 689.57
TOP OF VALVE EL. 685.4
(FULL OF WATER) |
| 5 | SANITARY MANHOLE
RIM EL. 692.58
6" W. I.E. 684.6
6" S. I.E. 684.6
6" N. I.E. 684.5 | | |

CONTROL POINTS

- | | |
|--|--|
| CP-3001
12" SPIKE IN BERM
N. 11,204.44
E. 10,707.66
EL. 699.82 | CP-3004
CUT "X" IN WALK
N. 11,122.86
E. 11,035.83
EL. 692.47 |
| CP-3002
CUT "X" IN WALK
N. 11,185.54
E. 10,709.31
EL. 697.87 | CP-3005
CUT SQUARE ON CONC. PAD
N. 11,219.71
E. 10,914.70
EL. 695.38 |
| CP-3002
CUT "X" IN CURB
N. 11,129.65
E. 11,057.61
EL. 692.56 | CP-3006
CUT "X" IN WALK
N. 11,181.49
E. 10,912.04
EL. 695.28 |

BENCH MARKS

LEGAL DESCRIPTION:
1330 Marseillaise Place
Aurora, Illinois 60506
Part of Lot 1 of the Aurora University 2nd Resubdivision as recorded in Kane County as Document Number 2019K005781, in the City of Aurora, County of Kane, Illinois.
Part of Parcel No. 15-20-451-006

Development Data Table: Final Plat		
Description	Value	Unit
a) Tax/Parcel Identification Number(s) (PINs): 15-20-451-006		
b) Subdivided Area	38.900	Acres
	-	Square Feet
c) Proposed New Right-of-way	-	Acres
	-	Square Feet
	-	Linear Feet of Centerline
d) Proposed New Easements	0.000	Acres
	-	Square Feet