

FINAL PLAN

FOR
ATMI PRECAST
1023 RIDGEWAY AVENUE
 CITY OF AURORA
 KANE COUNTY, ILLINOIS 60506

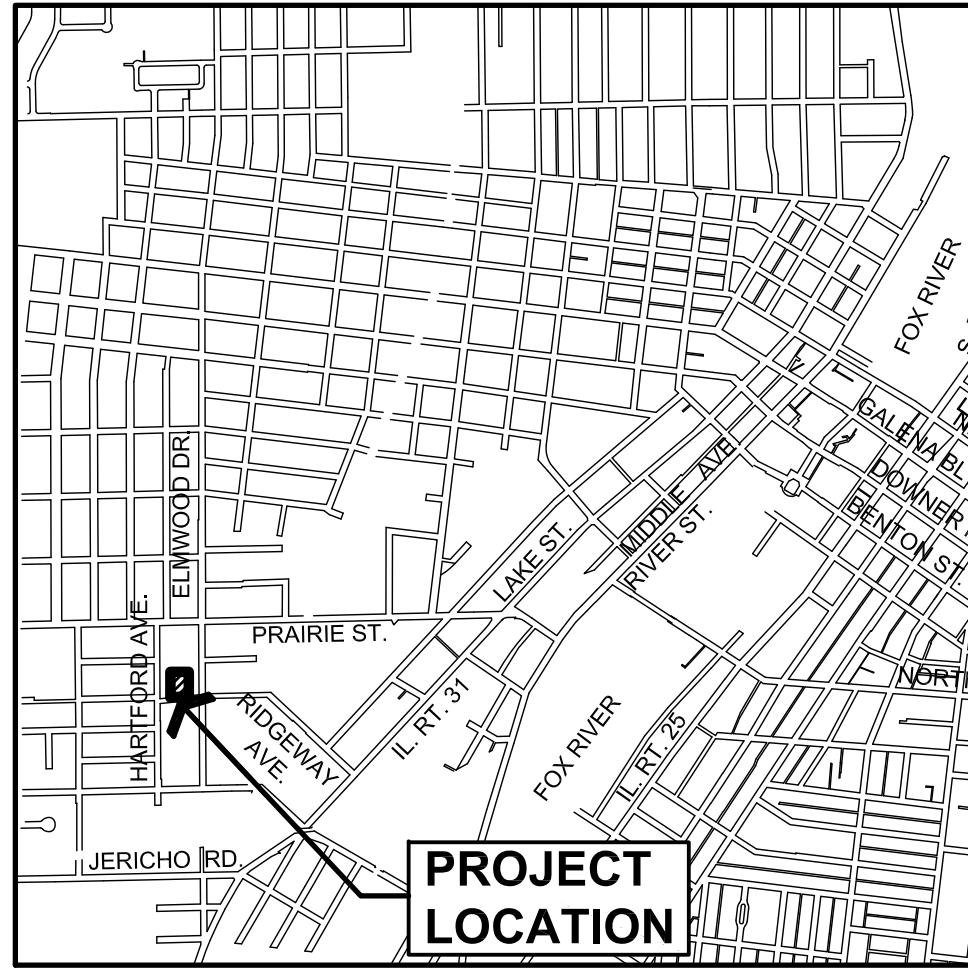

LOCATION MAP
 SCALE: 1" = 2,000'

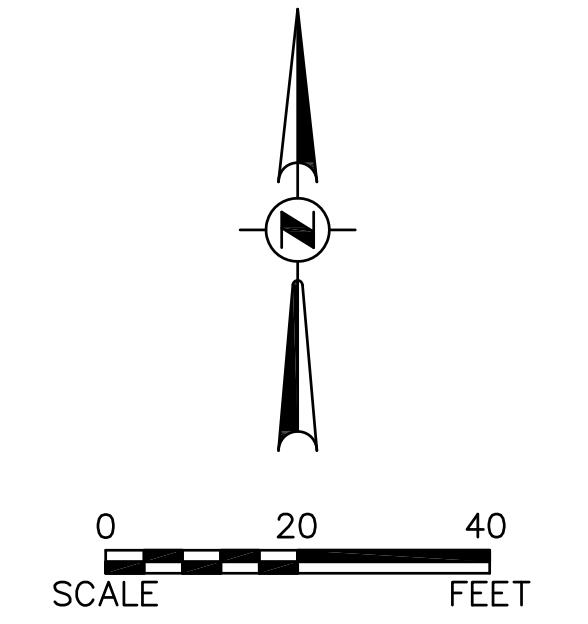
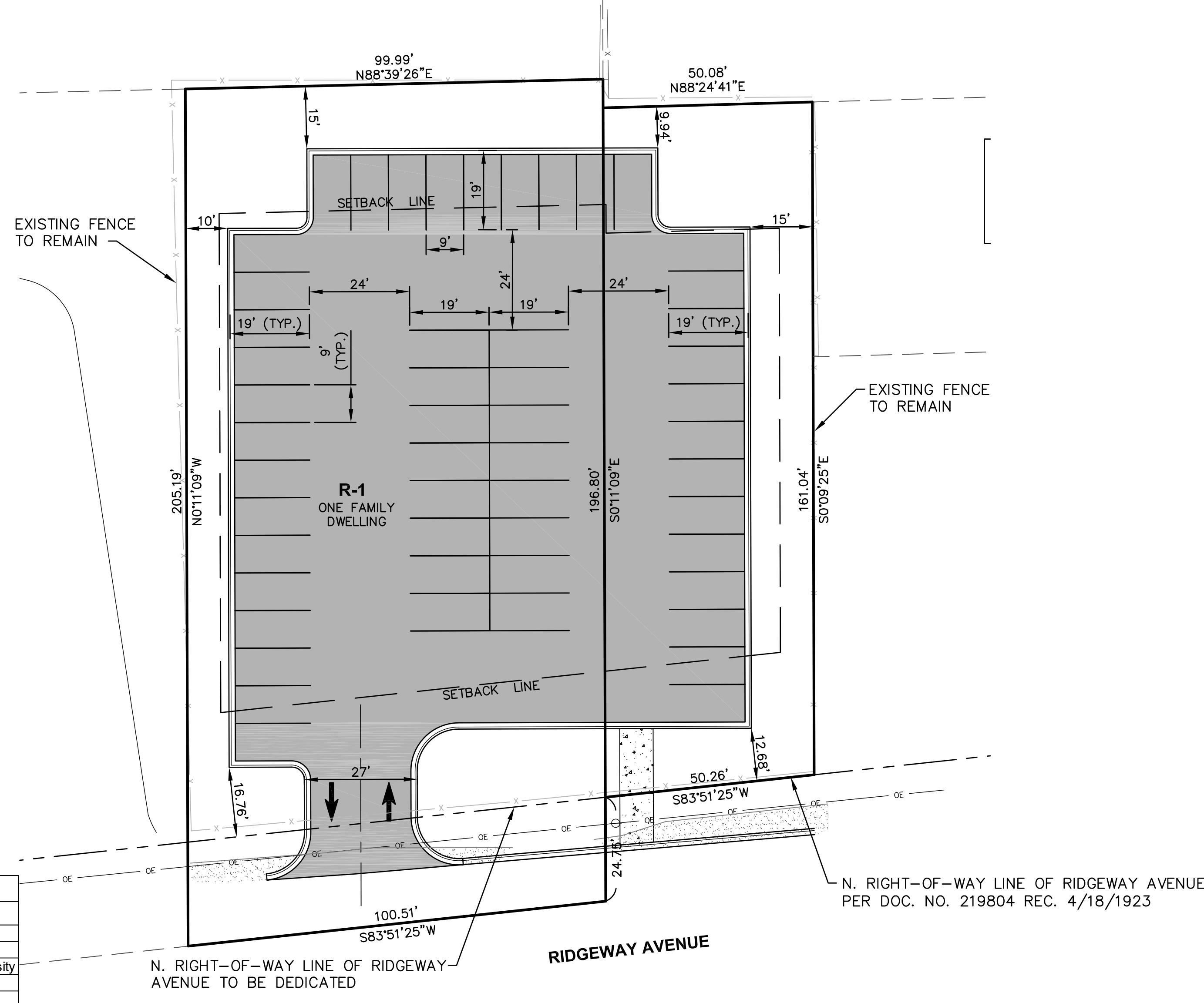

EXISTING	DESCRIPTION	PROPOSED
	SANITARY SEWER	
	STORM SEWER	
	END SECTION	
	WATER MAIN & SIZE	
	WATER SERVICE & BOX	
	SEWER SERVICE	
	CONTOUR	
	GAS MAIN	
	TELEPHONE CABLE	
	FIBER OPTIC	
	SILT FENCE	
	MANHOLE	
	CATCH BASIN	
	INLET	
	HYDRANT	
	VALVE VAULT	
	TREE	
	ELEVATION	
	TRENCH BACKFILL	
	STREET LIGHT	
	SIGNS	
	FOUND IRON PIPE	
	GUY WIRE	
	FLAG POLE	
	UTILITY POLE	
	UTILITY PEDESTAL	
	HANDHOLE	
	ITEM DESIGNATED FOR REMOVAL	
	TREE PROTECTION REQUIRED	
	BITUMINOUS PAVEMENT	
	CONCRETE	
	GRAVEL	
	DEPRESSED C & G	
	REVERSE PITCH C & G	
	CURB OPENING	
	PERMEABLE PAVING	

Description	Value	Unit	Description	Value	Unit
a) Tax/Parcel Identification Number(s) (PINs): 15-29-230-023; 15-29-230-024			j) Total Number of Residential Dwelling Units	0	units
b) Proposed land use(s): Parking Lot			i. Gross Density	0.00	du/acre
			ii. Net Density	0.00	Net Density
			k) Number of Single Family Dwelling Units	0	units
c) Total Property Size	0.65	Acres	i. Gross Density	0.00	du/acre
	28,249	Square feet	ii. Net Density	0.00	Net Density
	16,937	Square feet	iii. Unit Square Footage (average)	-	square feet
	80%	Percent	iv. Bedroom Mx	0%	% 1 bdr
d) Total Lot Coverage (buildings and pavement)	60%	Percent	v. Number of Single Family Corner Lots	0	units
	80%	Percent	vi. Number of Single Family Attached Dwelling Units	0	units
e) Open space / landscaping	11,312	Square feet	i. Gross Density	0.00	du/acre
	40%	Percent	ii. Net Density	0.00	Net Density
f) Land to be dedicated to the School District	0	Acres	iii. Unit Square Footage (average)	-	square feet
g) Land to be dedicated to the Park District	0	Acres	iv. Bedroom Mx	0%	% 1 bdr
h) Number of parking spaces provided (individually accessible)	52	spaces	i. Gross Density	0.00	du/acre
	52	spaces	ii. Net Density	0.00	Net Density
	52	spaces	iii. Unit Square Footage (average)	-	square feet
	0	spaces	iv. Bedroom Mx	0%	% 1 bdr
i. surface parking lot	0	spaces	v. Number of Single Family Corner Lots	0	units
	52	spaces	vi. Number of Single Family Attached Dwelling Units	0	units
	0	spaces	i. Gross Density	0.00	du/acre
	0	spaces	ii. Net Density	0.00	Net Density
ii. enclosed	0	spaces	iii. Unit Square Footage (average)	-	square feet
	0	racks	iv. Bedroom Mx	0%	% 1 bdr
	0	racks	i. Gross Density	0.00	du/acre
	0	racks	ii. Net Density	0.00	Net Density
j) Number of buildings	0	spaces	iii. Unit Square Footage (average)	-	square feet
	0	spaces	iv. Bedroom Mx	0%	% 1 bdr
	0	spaces	i. Gross Density	0.00	du/acre
	0	spaces	ii. Net Density	0.00	Net Density
k) Building Square Footage (typical)	0	spaces	iii. Unit Square Footage (average)	-	square feet
	0	spaces	iv. Bedroom Mx	0%	% 1 bdr
	0	spaces	i. Gross Density	0.00	du/acre
	0	spaces	ii. Net Density	0.00	Net Density
l) First Floor Building Square Footage (typical)	0	spaces	iii. Unit Square Footage (average)	-	square feet
	0	spaces	iv. Bedroom Mx	0%	% 1 bdr
	0	spaces	i. Gross Density	0.00	du/acre
	0	spaces	ii. Net Density	0.00	Net Density

Plotted: August 16, 2017 1:57 PM By: Lerry Nelson - Tab: Final Plan (24x36)

Path: \\SBSK\PROJ\17012\DWG_FINAL_ENG\17012-FINAL_PLAN

Engineering Enterprises, Inc. CONSULTING ENGINEERS 52 Wheeler Road Sugar Grove, Illinois 60554 630.466.6700 / www.eeiweb.com	ATMI PRECAST 659 S. ELMWOOD DR. AURORA, ILLINOIS 60506	1 8/14/17 PER CITY COMMENTS NO. DATE PER CITY COMMENTS REVISIONS	ATMI PRECAST 1023 RIDGEWAY AVE. AURORA, ILLINOIS	FINAL PLAN	DATE: AUGUST 10, 2017
					PROJECT NO: P17012
FILE NO: P17012-FINAL PLAN					
SHEET 1 OF 1					