

PROPOSAL SUBMITTED BY:

Performance Construction & Engineering, LLC

Contractor's Name

217 W. John Street

Street

P.O. Box

Plano

IL

60545

City

State

Zip Code



**CITY OF AURORA
KANE COUNTY
STATE OF ILLINOIS**

**PROPOSAL AND SPECIFICATIONS FOR
77 S. Broadway Ave. Parking Structure
& 65 Water St. Demolition Project
Bid 18-23**

**AURORA, ILLINOIS
2018**

**PREPARED BY
CITY OF AURORA
Engineering Division
44 EAST DOWNER PLACE
AURORA, ILLINOIS 60507**

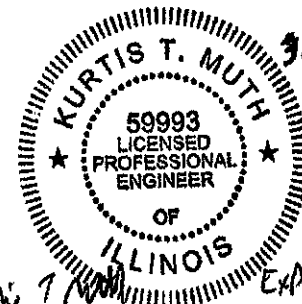

3/13/18

EXP
11/30/18

TO: THE HONORABLE MAYOR AND CITY COUNCIL
CITY OF AURORA
44 EAST DOWNER PLACE
AURORA, ILLINOIS 60507

1. Proposal of Performance Construction & Engineering, LLC
for the improvement known as the 77 S. Broadway Ave. Parking Structure & 65 Water St. Demolition Project, Bid 18-23.
2. The plans and specifications for the proposed improvements are those prepared by the City of Aurora Engineering Division and approved by the City Council of Aurora, Illinois.
3. In submitting this proposal, the undersigned declares that the only persons or parties interested in the proposal as principals are those named herein, and that the proposal is made without collusion with any person, firm, or corporation.
4. The undersigned further declares that he has carefully examined the proposals, plans, specifications, form of contract and contract bond, and special provisions, if any, and that he has inspected in detail the site of the proposed work and that he has familiarized himself with all of the local conditions affecting the contract and detailed requirements of construction, and understands that in making this proposal he waives all right to plead any misunderstanding regarding the same.
5. The undersigned further understands and agrees that if the proposal is accepted, he is to furnish and provide all necessary machinery, tools, apparatus and other means of construction and to do all of the work and to furnish all of the materials and labor required.
6. The undersigned declares that he understands that the quantities mentioned are approximate only, and that they are subject to increase or decrease; that he will take in full payment therefore the amount of the summation of the actual quantities, as finally determined, and multiplied by the unit prices shown in the schedule of prices contained herein.
7. The undersigned agrees that the unit prices submitted herewith are for the purpose of obtaining a gross sum and for use in computing the value of extras and deductions; that if there is a discrepancy between the gross sum bid and that resulting from the summation of the quantities multiplied by their respective unit prices, the latter shall apply.
8. The undersigned agrees that if the City decides to extend or shorten the improvement, or otherwise alter it by extras or deductions, including the elimination of any one or more of the items, as provided in the specifications, he will perform the work as altered, increased or decreased, at the contract unit prices without claim for profits lost as a result of any work or items eliminated by the City of Aurora.
9. The undersigned agrees that the Engineer may, at any time during the progress of the work covered by this contract, order other work or materials incidental thereto, and that all such work and materials as do not appear in the proposal or contract as a specific item accompanied by a unit price, and which are not included under the bid price for other items in this contract, shall be performed as extra work, and that he will accept as full compensation therefore the actual cost plus ten percent (10%), the actual cost to be determined as provided for in the specifications.
10. The undersigned further agrees to execute a contract, a contract bond satisfactory to and in the form prescribed by the City in the penal sum of the full amount of the contract, guaranteeing the faithful performance of the work in accordance with the terms of the contract within **fifteen (15)** days after receiving the notice of award of the contract.
11. The undersigned further agrees to begin work not later than **ten (10)** calendar days after the execution or by the date stated within the contract documents and approval of the contract and contract bond, unless otherwise provided, and to prosecute the work in such a manner and with sufficient materials, equipment,

and labor as will insure its completion within the time limit specified herein, it being understood and agreed that the completion within the time limit is an essential part of the contract.

12. The undersigned agrees to complete the work within the time stipulated in the Special Provisions.
13. All work shall be completed to the satisfaction of the Engineer by the above dates unless the Engineer in accordance with the specifications grants additional time. In case of failure to complete the work within the time named herein, or within such extra time as may have been allowed by extensions, the undersigned agrees that the City shall withhold from such sums as may be due him under the terms of the contract the liquidated damages as set forth in the Standard Specifications, which costs shall be considered and treated not as a penalty, but as damages due the Municipality from the undersigned by reason of inconvenience to the public, added cost of engineering and supervision, and other items which have caused an expenditure of public funds resulting from the failure of the undersigned to complete the work within the time specified in the contract.
14. If this proposal is accepted and the undersigned shall fail to execute a contract and contract bond as required herein, it is hereby agreed that the amount of the check or draft or bidder's bond substituted in lieu thereof shall become the property of the City and shall be considered not as a penalty but as payment of liquidated damages due to delay and other causes suffered by the City because of the failure to execute said contract and contract bond, otherwise said check or draft or bidder's bond substituted in lieu thereof shall be returned to the undersigned.
15. Accompanying this proposal is either a **5% Bid Bond** or a proposal guaranty check, complying with the specifications, made payable to the City Treasurer of the City of Aurora. The amount of the check is \$

16. The undersigned submits herewith his schedule of prices covering the work to be performed under this contract, he understands that he must show in the schedule the unit prices for which he proposes to perform each item of work, that the extensions must be made by him, and that if not so done, his proposal may be rejected as irregular or non-responsive.
17. The undersigned agrees to conform to Section 100 of the Standard Specifications and to Article 107.27 of that section indemnifying and saving harmless the City of Aurora and its officers, agents, and employees. The Contractor shall provide insurance with limits as stated in the Article 6.7 of the *City of Aurora - General Specifications*.
18. The City of Aurora reserves the right to reject any or all of the bids and to waive any and all irregularities and technicalities. The City of Aurora shall either award the project or reject the bids within Sixty (60) calendar days after the bid opening. This time frame may be extended upon mutual agreement of the City and the Bidder.
19. The undersigned of this proposal agrees that he or she has examined all sections of this Proposal, Specifications, and Bidding Documents and hereby understands and accepts the provisions for access, or the lack of access, to the construction site and shall claim no compensation other than the prices as bid for this condition of accessibility.
20. The undersigned further agrees that the unit prices submitted herewith are for the complete item constructed, including all labor, equipment, material and other necessary incidental work.
21. The undersigned agrees to indemnifying and saving harmless the City of Aurora, its officers, agents, employees, and servants by filing with the City, prior to the execution of the contract, copies of completed Certificates of Insurance satisfactory to the City, with the City of Aurora named as co-insured; automobile liability insurance covering owned, non-owned, and hired vehicles with limits of liability as stated in the City of Aurora - General Specifications Article 6.7.

22. No bid shall be considered unless the party offering it shall furnish evidence satisfactory to the City of Aurora that he has been previously engaged in the quality construction of improvements of the same character as the one herein specified, and that he has the necessary facilities, equipment, experience, and ability and pecuniary resources to fulfill the conditions of the contract
23. No contract will be awarded to any bidder where that bidder or any principal or supervisory personnel of the bidder has been personally involved with another business that has been delinquent or unfaithful in any former contract with the City or where that bidder or any supervisory personnel of the bidder has been personally involved with another business that is a defaulter as surety or otherwise upon obligation to the City.
24. The Illinois Freedom of Information Act (FOIA) has been amended and effective January 1, 2010, adds a new provision to Section 7 of the Act which applies to public records in the possession of a party with whom the City of Aurora has contracted. The City of Aurora will have only a very short period of time from receipt of a FOIA request to comply with the request, and there is a significant amount of work required to process a request including collating and reviewing the information. The undersigned acknowledges the requirements of FOIA and agrees to comply with all requests made by the City of Aurora for public records (as that term is defined by Section 2(c) of FOIA) in the undersigned's possession and to provide the requested public records to the City of Aurora within two (2) business days of the request being made by the City of Aurora. The undersigned agrees to indemnify and hold harmless the City of Aurora from all claims, costs, penalty, losses and injuries (including but not limited to, attorney's fees, other professional fees, court costs and/or arbitration or other dispute resolution costs) arising out of or relating to its failure to provide the public records to the City of Aurora under this agreement.
25. The undersigned submits herewith this **Schedule of Prices** covering the work to be performed under this contract:



Schedule of Prices
77 S. Broadway Ave. Parking Structure
& 65 Water St Demolition Project
B18-23

Route S. Broadway Ave. & Water St.
 County Kane
 Local Agency City of Aurora

RETURN WITH BID

Addendum No. 1

(For complete information covering these items, see plans and specifications)

NO.	ITEM	UNIT	QUANTITY	UNIT COST	AMOUNT
1	6' Chain Link Temporary Construction Perimeter Fence	FT	800	5.00	4,000.00
2	Tree removal (6-15 units)	UNIT	6	125.00	750.00
3	65 Water St Trash Enclosure Fence Removal	LS	1	1,500.00	1,500.00
4	Curb and Gutter Removal	FT	150	5.00	750.00
5	Sidewalk Removal (Adjacent to 65 Water St)	SF	1,000	0.50	500.00
6	Light Pole Foundation Removal (65 Water St)	EA	1	500.00	500.00
7	65 Water Street Building Demolition	LS	1	80,000.00	80,000.00
8	77 S. Broadway Avenue Parking Structure Demolition	LS	1	163,445.00	163,445.00
9	77 S. Broadway Avenue Interior Building Demolition	LS	1	10,000.00	10,000.00
10	Communications Service Conduit Installation & Wall Bracing	FT	60	40.00	2,400.00
11	Excavation for Structural Concrete	CY	30	50.00	1,500.00
12	Concrete Structures	CY	70	1,000.00	70,000.00
13	Exterior Stair Railing, 3' Tall	FT	20	75.00	1,500.00
14	Stairwell Gate	FT	4	500.00	2,000.00
15	Removal of Cladding on Three East Columns	LS	1	4,500.00	4,500.00
16	Fill Drive Trough Tunnel	CY	35	30.00	1,050.00
17	Masonry Wall (NE stairwell doorways, Non-structural)	SF	60	35.00	2,100.00
18	Foundation Waterproofing	SF	2,400	3.50	8,400.00
19	Drain Tile, 6" Perforated PVC SDR-26	FT	350	20.00	7,000.00
20	Connect drain tiles with 6" Wye connection	EA	1	500.00	500.00
21	Connect proposed underdrain to existing storm sewer	EA	2	1,000.00	2,000.00
22	Aggregate Base Course, Tye A, 12"	SY	900	18.00	16,200.00
23	Bituminous Materials (Prime Coat)	GAL	600	5.00	3,000.00
24	Hot Mix Asphalt, Binder Course, N50, 2.5"	TON	208	80.00	16,640.00
25	Hot Mix Asphalt, Surface Course, N50, 1-1/2"	TON	80	97.00	7,760.00
26	Class D Patching, 10"	SY	50	110.00	5,500.00

NO.	ITEM	UNIT	QUANTITY	UNIT COST	AMOUNT
27	Surface Course Removal	SY	20	20.00	400.00
28	6" PCC Barrier Curb	FT	110	23.00	2,530.00
29	10" PCC Barrier Curb	FT	60	28.00	1,680.00
30	Concrete Flume, 6" Thick	SF	25	24.00	600.00
31	Install Furnished Brick	SF	250	15.00	3,750.00
32	Furnish and Install Common Brick	SF	500	25.00	12,500.00
33	Bollard, 6" Dia., 6' tall, 3' Bury	EA	1	1,000.00	1,000.00
34	Bollard Removal	EA	2	200.00	400.00
35	Concrete Apron Removal	SY	25	75.00	1,875.00
36	Combination PCC Curb & Gutter Removal and Replacement	FT	210	30.00	6,300.00
37	Decorative Fence, 4'	FT	110	50.00	5,500.00
38	PCC Sidewalk Rem. and Replace, 5"	SF	2,000	7.40	14,800.00
39	PCC Sidewalk, 5" w/Welded Wire Fabric & Aggregate Base	SF	2,050	7.60	15,580.00
40	Detectable Warnings	SF	100	22.00	2,200.00
41	Brick Ribbon Removal and Replacement	SF	330	15.00	4,950.00
42	Brick Ribbon Installation	SF	180	10.00	1,800.00
43	Seal Coat	SY	450	3.00	1,350.00
44	Paint Pavement Marking - Line, 4"	FT	1,500	2.00	3,000.00
45	Paint Pavement Marking - Letters & Symbols	SF	55	10.00	550.00
46	Topsoil, 6" (Landscape Islands only)	SY	140	6.00	840.00
47	Seeding - Aurora Mix	SY	2,000	3.00	6,000.00
48	Items Ordered by Engineer	Allowance	1	\$50,000.00	\$50,000.00
49	Traffic Control and Protection	LS	1	25,000.00	25,000.00
50	Inlet Protection	EACH	5	200.00	1,000.00
51	Silt Fence	FT	60	5.00	300.00
52	Dewatering Bag	EACH	1	600.00	600.00
Bidder's Total Proposal for Making Base Bid Improvements (Addendum No. 1) =					\$ 578,000.00



Signatures

(If an individual)

Signature of Bidder _____

Business Address _____

(If a partnership)

Firm Name _____

Signed by _____

Business Address _____

Insert
Names and
Addresses of
All Partners

(If a corporation)

Corporate Name Performance Construction & Engineering, LLC

Signed By 

President

Business Address 217 W. John Street

Plano, IL 60545

President Lonnie Avery

Secretary _____

Treasurer K. Paul Corbin

Attest: 

Secretary



Route Various
County Kane
Local Agency City of Aurora
Section

RETURN WITH BID

PAPER BID BOND

WE Performance Construction and Engineering, LLC as PRINCIPAL, and Merchants Bonding Company (Mutual) as SURETY,

are held jointly, severally and firmly bound unto the above Local Agency (hereafter referred to as "LA") in the penal sum of 5% of the total bid price, or for the amount specified in the proposal documents in effect on the date of invitation for bids whichever is the lesser sum.

WHEREAS THE CONDITION OF THE FOREGOING OBLIGATION IS SUCH that, the said PRINCIPAL is submitting a written proposal to the LA acting through its awarding authority for the construction of the work designated as the above section.

THEREFORE if the proposal is accepted and a contract awarded to the PRINCIPAL by the LA for the above designated section and the PRINCIPAL shall within fifteen (15) days after award enter into a formal contract, furnish surety guaranteeing the faithful performance of the work, and furnish evidence of the required insurance coverage, all as provided in the "Standard Specifications for Road and Bridge Construction" and applicable Supplemental Specifications, then this obligation shall become void; otherwise it shall remain in full force and effect.

IN THE EVENT the LA determines the PRINCIPAL has failed to enter into a formal contract in compliance with any requirements set forth in the preceding paragraph, then the LA acting through its awarding authority shall immediately be entitled to recover the full penal sum set out above, together with all court costs, all attorney fees, and any other expense of recovery.

IN TESTIMONY WHEREOF, the said PRINCIPAL and the said SURETY have caused this instrument to be signed by their respective officers this 22nd day of March, 2018

Principal

Performance Construction and Engineering, LLC

By: Lonnie Avery, President (Signature and Title)

(Company Name) (Signature and Title)

(If PRINCIPLE is a joint venture of two or more contractors, the company names, and authorized signatures of each contractor must be affixed.)

Surety

Merchants Bonding Company (Mutual)

By: Dione R. Young, Attorney-in-Fact (Signature of Attorney-in-Fact)

STATE OF ILLINOIS, Iowa
COUNTY OF Dallas

I, Anne Crowner, a Notary Public in and for said county, do hereby certify that Lonnie Avery and Dione R. Young

(Insert names of individuals signing on behalf of PRINCIPAL & SURETY)

who are each personally known to me to be the same persons whose names are subscribed to the foregoing instrument on behalf of PRINCIPAL and SURETY, appeared before me this day in person and acknowledged respectively, that they signed and delivered said instruments as their free and voluntary act for the uses and purposes therein set forth.

Given under my hand and notarial seal this 22nd day of March, 2018

My commission expires 7/21/2018

Anne Crowner (Notary Public)

ELECTRONIC BID BOND

Electronic bid bond is allowed (box must be checked by LA if electronic bid bond is allowed)

The Principal may submit an electronic bid bond, in lieu of completing the above section of the Proposal Bid Bond Form. By providing an electronic bid bond ID code and signing below, the Principal is ensuring the identified electronic bid bond has been executed and the Principal and Surety are firmly bound unto the LA under the conditions of the bid bond as shown above.

Electronic Bid Bond ID Code

(Company/Bidder Name)

(Signature and Title)

Date

MERCHANTS BONDING COMPANY™

POWER OF ATTORNEY

Know All Persons By These Presents, that MERCHANTS BONDING COMPANY (MUTUAL) and MERCHANTS NATIONAL BONDING, INC., both being corporations of the State of Iowa (herein collectively called the "Companies") do hereby make, constitute and appoint, individually, Anne Crowner; Brian M Deimerly; Cameron M Burt; Cindy Bennett; Craig E Hansen; Dana Wiebers; Dione R Young; Jay D Freiermuth; Jody Decker; Kami Brower; Kathleen Brewer; Kevin J Knutson; Michelle R Gruis; Shirley S Bartenhagen; Stacy Venn; Tim McCulloh

their true and lawful Attorney(s)-in-Fact, to sign its name as surety(ies) and to execute, seal and acknowledge any and all bonds, undertakings, contracts and other written instruments in the nature thereof, on behalf of the Companies in their business of guaranteeing the fidelity of persons, guaranteeing the performance of contracts and executing or guaranteeing bonds and undertakings required or permitted in any actions or proceedings allowed by law.

This Power-of-Attorney is granted and is signed and sealed by facsimile under and by authority of the following By-Laws adopted by the Board of Directors of Merchants Bonding Company (Mutual) on April 23, 2011 and amended August 14, 2015 and adopted by the Board of Directors of Merchants National Bonding, Inc., on October 16, 2015.

"The President, Secretary, Treasurer, or any Assistant Treasurer or any Assistant Secretary or any Vice President shall have power and authority to appoint Attorneys-in-Fact, and to authorize them to execute on behalf of the Company, and attach the seal of the Company thereto, bonds and undertakings, recognizances, contracts of indemnity and other writings obligatory in the nature thereof."

"The signature of any authorized officer and the seal of the Company may be affixed by facsimile or electronic transmission to any Power of Attorney or Certification thereof authorizing the execution and delivery of any bond, undertaking, recognizance, or other suretyship obligations of the Company, and such signature and seal when so used shall have the same force and effect as though manually fixed."

In connection with obligations in favor of the Florida Department of Transportation only, it is agreed that the power and authority hereby given to the Attorney-in-Fact includes any and all consents for the release of retained percentages and/or final estimates on engineering and construction contracts required by the State of Florida Department of Transportation. It is fully understood that consenting to the State of Florida Department of Transportation making payment of the final estimate to the Contractor and/or its assignee, shall not relieve this surety company of any of its obligations under its bond.

In connection with obligations in favor of the Kentucky Department of Highways only, it is agreed that the power and authority hereby given to the Attorney-in-Fact cannot be modified or revoked unless prior written personal notice of such intent has been given to the Commissioner-Department of Highways of the Commonwealth of Kentucky at least thirty (30) days prior to the modification or revocation.

In Witness Whereof, the Companies have caused this instrument to be signed and sealed this 7th day of November, 2017.

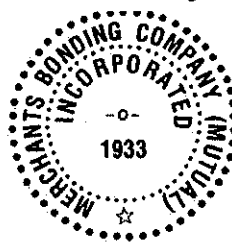

MERCHANTS BONDING COMPANY (MUTUAL)
MERCHANTS NATIONAL BONDING, INC.

By *Larry Taylor*
President

STATE OF IOWA
COUNTY OF DALLAS ss.

On this this 7th day of November 2017, before me appeared Larry Taylor, to me personally known, who being by me duly sworn did say that he is President of MERCHANTS BONDING COMPANY (MUTUAL) and MERCHANTS NATIONAL BONDING, INC.; and that the seals affixed to the foregoing instrument are the Corporate Seals of the Companies; and that the said instrument was signed and sealed in behalf of the Companies by authority of their respective Boards of Directors.

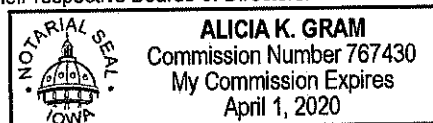

Alicia K. Gram
Notary Public

(Expiration of notary's commission
does not invalidate this instrument)

I, William Warner, Jr., Secretary of MERCHANTS BONDING COMPANY (MUTUAL) and MERCHANTS NATIONAL BONDING, INC., do hereby certify that the above and foregoing is a true and correct copy of the POWER-OF-ATTORNEY executed by said Companies, which is still in full force and effect and has not been amended or revoked.

In Witness Whereof, I have hereunto set my hand and affixed the seal of the Companies on this 22nd day of March, 2018.



William Warner Jr.
Secretary

BIDDER'S CERTIFICATION

I/We hereby certify that:

- A. A complete set of bid papers, as intended, has been received, and that I/We will abide by the contents and/or information received and/or contained herein.
- B. I/We have not entered into any collusion or other unethical practices with any person, firm, or employee of the City which would in any way be construed as unethical business practice.
- C. I/We have adopted a written sexual harassment policy which is in accordance with the requirements of Federal, State and local laws, regulations and policies and further certify that I/We are also in compliance with all other equal employment requirements contained in Public Act 87-1257 (effective July 1, 1993) 775 ILCS 5/2-105 (A).
- D. I/We are in compliance with the most current "Prevailing Rate" of wages for laborers, mechanics and other workers as required by the City of Aurora Ordinance No. O17-029, adopted on June 27, 2017.
- E. I/We operate a drug free environment and drugs are not allowed in the workplace or satellite locations as well as City of Aurora sites in accordance with the Drug Free Workplace Act of January, 1992.
- F. The Bidder is not barred from bidding on the Project, or entering into this contract as a result of a violation of either Section 33E-3 or 33E-4 of the Illinois Criminal Code, or any similar offense of "bid rigging" or "bid rotating" of any state or the United States.
- G. I/We will submit with our bid, for all contracts in excess of \$25,000.00, a certificate indicating participation in apprenticeship and training programs approved and registered with the United States Department of Labor.

Contractor shall check the box indicating that a copy of applicable program certification is attached.

H. I/We will abide by all other Federal, State and local codes, rules, regulations, ordinances and statutes.

COMPANY NAME Performance Construction & Engineering, LLC

ADDRESS 217 W. John Street

CITY/STATE/ZIP CODE Plano, IL 60545

NAME OF CORPORATE/COMPANY OFFICIAL Lonnie Avery
PLEASE TYPE OR PRINT CLEARLY

TITLE President

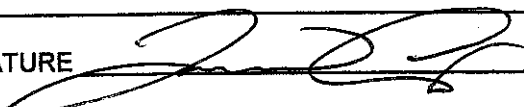
AUTHORIZED OFFICIAL SIGNATURE 

DATE March 28, 2018

Subscribed and Sworn to

TELEPHONE (630) 918-1237

Before me this 28th day

FAX No. () N/A

of March, 2018

Notary Public

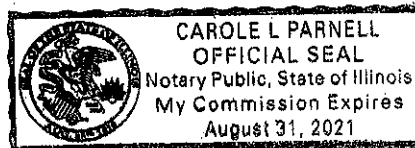

INTERNATIONAL UNION OF OPERATING ENGINEERS

LOCAL UNION NO. 150, 150B, 150A, 150C, 150RA, 150D, 150G, 150M

AFFILIATED WITH THE A.F.L.-C.I.O. AND BUILDING TRADES DEPARTMENT

JAMES M. SWEENEY
PRESIDENT-BUSINESS MANAGER



(708) 482-8800 - FAX (708) 482-7186
6200 JOLIET ROAD
COUNTRYSIDE, IL 60525-3992

January 16, 2017

Performance Construction & Engineering. Otherwise known as P.C.E

Re: Proof of Compliance with 30 ILCS 500/30-22(6)
Our File No. MI-00321

Dear Sir or Madam:

At the request of P.C.E, I am providing you with evidence of the Company's compliance with the apprenticeship requirements in 30 ILCS 500/30-22(6) of the Illinois Procurement Code. I am submitting this letter along with apprenticeship certificates (Nos.IL012020003, IL008780173).

As a signatory contractor with the International Union of Operating Engineers, Local 150, AFL-CIO, P.C.E. is required by Collective Bargaining Agreement to participate in an applicable apprenticeship and training program approved by and registered with the United States Department of Labor's Bureau of Apprenticeship and Training. The attached certificates are evidence of compliance with the U.S. Department of Labor's apprenticeship requirements.

Thank you for your cooperation in this matter. If you have any questions or concerns, please do not hesitate to contact me.

Very truly yours,

IUOE, Local 150, AFL-CIO
District 2 dispatch office

Virginia Turvey

VT

Enclosures: Certificates

UNITED STATES DEPARTMENT OF LABOR

**Office of Apprenticeship Training, Employer and Labor Services
Bureau of Apprenticeship and Training**

Certificate of Registration

*Heavy Equipment Technician Operating Engineers Local #150
Plainfield, Illinois*

For the Trade of Repairer(Heavy)

Registered as part of the National Apprenticeship Program

in accordance with the basic standards of apprenticeship

established by the Secretary of Labor



May 5, 2002

Date

IL012020003

Registration No.

Do. J. Chao

Secretary of Labor

Anthony Swartz

Administrator, Apprenticeship Training, Employer and Labor Services

UNITED STATES DEPARTMENT OF LABOR
Bureau of Apprenticeship Training, Employer and Labor Services

Office of Apprenticeship Training, Employer and Labor Services
Bureau of Apprenticeship and Training

Certificate of Registration

Operating Engineers Local #150

Plainfield, Illinois

For the Trade of Operating Engineer

Registered as part of the National Apprenticeship Program

in accordance with the basic standards of apprenticeship

established by the Secretary of Labor



November 5, 2002

Date

LC 008780173

Registration No.

Scott Chao

Secretary of Labor

Anthony S. ...

Administrator, Apprenticeship Training, Employer and Labor Services

Chicagoland
LABORERS'
District Council Training & Apprentices Fund

www.chicagolaborers.org

16 January 2017

Executive Director

Thomas Nordeen

Labor Trustees

James P. Connolly
Martin Flanagan
Joseph V. Healy
Charles V. LoVerde III
Joe Riley

Management Trustees

Seth Gudeman
Shane Higgins
Joseph Koppers
Robert G. Krug
David Lorig
William Vignocchi

Mr. Lonnie Avery
722 E. South St. Unit B
Plano, IL 60545

Dear Mr. Avery

Enclosed you will please find a copy of the Department of Labor certification that you requested recently.

You may also use this letter as verification that Performance Construction and Engineering, LLC is indeed signatory to the Fox Valley Laborers' Health & Welfare Fund and contributes to the Laborers' Apprenticeship Fund.

Should you require anything further, please do not hesitate to contact me.

Yours very truly,



Miranda Maddie
Office Manager

Carol Stream Location

1200 Old Gary Avenue
Carol Stream IL 60188
630.653.0006

LiUNA!

Feel the Power

Chicago Location

5700 West Homer Street
Chicago IL 60639
773.413.3315

Apprenticeship or Training Program Certification

Return with Bid

All contractors are required to complete the following certification:

- For this contract proposal or for all groups in this deliver and install proposal.
- For the following deliver and install groups in this material proposal:

The City of Aurora policy, adopted in accordance with the provisions of the Illinois Highway Code, requires this contract to be awarded to the lowest responsive and responsible bidder. In addition to all other responsibility factors, this contract or deliver and install proposal requires all bidders and all bidders' subcontractors to disclose participation in apprenticeship or training programs that are approved by and registered with the United States Department of Labor's Bureau of Apprenticeship and Training, and applicable to the work of the above indicated proposals or groups. Therefore, all bidders are required to complete the following certification:

- I. Except as provided in paragraph IV below, the undersigned bidder certifies that it is a participant, either as an individual or as part of a group program, in an approved apprenticeship or training program applicable to each type of work or craft that the bidder will perform with its own employees.
- II. The undersigned bidder further certifies for work to be performed by subcontract that each of its subcontractors submitted for approval is, at the time of such bid, participating in an approved, applicable apprenticeship or training program applicable to the work of the subcontract.
- III. The undersigned bidder, by inclusion in the list in the space below, certifies the official name of each program sponsor holding the Certificate of Registration for all of the types of work or crafts in which the bidder is a participant and that will be performed with the bidder's employees. Types of work or craft that will be subcontracted shall be included and listed as subcontract work. The list shall also indicate any type of work or craft job category for which there is no applicable apprenticeship or training program available.

Stokes Excating

VI. Except for any work identified above, any bidder or subcontractor that shall perform all or part of the work of the contract or deliver and install proposal solely by individual owners, partners or members and not by employees to whom the payment of prevailing rates of wages would be required, check the following box, and identify the owner/operator workforce and positions of ownership.

The requirements of this certification and disclosure are a material part of the contract, and the contractor shall require this certification provision to be included in all approved subcontracts. The bidder is responsible for making a complete report and shall make certain that each type of work or craft job category that will be utilized on the project is accounted for and listed. **The City of Aurora requires a copy of each applicable Certificate of Registration issued by the United States Department of Labor evidencing such participation by the contractor and any or all of its subcontractors be included with the bid in order to qualify to bid on the project.**

Bidder: Performance Construction & Engineering, LLC

Address: 217 W. John Street, Plano, IL 60545

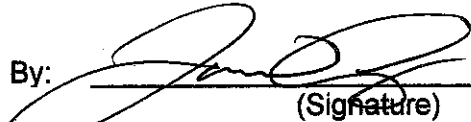
By: 
(Signature)
Title: President

STATE OF ILLINOIS)
County of Kane) ss.

BIDDER'S TAX CERTIFICATION

(BIDDER'S EXECUTING OFFICER), being first duly sworn on oath, deposes and states that all statements made herein are made on behalf of the Bidder, that this despondent is authorized to make them and that the statements contained herein are true and correct.

Bidder deposes, states and certifies that Bidder is not barred from contracting with any unit of local government in the State of Illinois as result of a delinquency in payment of any tax administered by the Illinois Department of Revenue unless Bidder is contesting, in accordance with the procedures established by the appropriate statute, its liability for the tax or the amount of the tax, all as provided for in accordance with 65 ILCS 5/11-42.1-1.

DATED this 28th day of March, 2018.

By [Signature] (Signature of Bidder's Executing Officer)

Lonnie Avery (Print name of Bidder's Executing Officer)

President (Title)

ATTEST/WITNESS:

By [Signature] Title Secretary

Subscribed and sworn to before me this 28th day of March, 2018.

[Signature] Notary Public

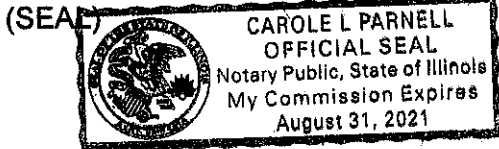

B18-23

**77 S. Broadway Ave Parking Structure and 65 Water St Demolition Project
Bid opening – ~~March 28, 2018~~ April 2, 2018 @ 2 p.m.**

ADDENDUM NO. 1

Page 1 of 10

TO: All Bidders

FROM: Engineering Division, City of Aurora

DATE: March 23, 2018

THIS ADDENDUM FORMS A PART OF THE BIDDING AND CONTRACT DOCUMENTS.

1. The bid opening will be rescheduled for April 2, 2018 at 2 p.m. in City Council Chambers.
2. The outline from the March 21st mandatory pre-bid meeting and attendance list are included with this addendum.
3. The IDOT prequalification mentioned in the bidder instruction item 3 of the advertisement will not be required for this project.
4. The allowable working days for this contract will be increased to 70 days.
5. All material left onsite shall be in general accordance with CCDD acceptable fill and shall generally be minus 6"; no pieces larger than 1' will be allowed. Materials that are not in conformance with general CCDD guidelines shall be removed and recycled or removed and transported to an appropriate landfill by the contractor (included in the cost of the demolition). Any equipment and efforts required to meet the size requirements shall be included in the cost of the demolition. The City will provide testing services to confirm that the minimum compaction requirements are met.
6. The contractor shall provide continual dust control during the demolition; debris outside the limit of construction fencing shall be addressed immediately and not only at the end of the day. If the contractor intends to use water to control the dust, a meter shall be obtained per the protocol outlined in the specifications; the cost of any water used shall be considered included in the cost of the demolition.
7. Doorways in northeast stairwell are to be abandoned with the Masonry Wall pay item.
8. The City is currently coordinating the relocation of the gas meter with Nicor. It is anticipated that at least a portion of the demolition will need to be completed prior to relocating the meter.
9. The Contractor will be required to protect the existing AT&T line in the parking garage during demolition.
10. The City will provide final grades for 65 Water Street once the building is removed; the final pavement grade will match the existing adjacent lots to the north and south.
11. 65 Water Street to be excavated down to proposed pavement subgrade elevation and any footings to be removed to at least that elevation.
12. The pavement section at 65 Water Street will be 12" aggregate base course, 2.5" binder course, & 1.5" surface course. The binder course thickness will be revised in the schedule of prices.

77 S. BROADWAY AVE. PARKING STRUCTURE AND 65 WATER ST DEMOLITION PROJECT - ADDENDUM NO. 1

13. The concrete entrance to the parking structure ramp on Benton is to be removed. The schedule of prices will be updated to include the necessary bid items and quantities.
14. It was confirmed that the drive through tunnel was not previously filled so the exploratory excavation pay item has been removed.
15. The disconnection of the electrical services entering the underground garage pump room from the 77 S. Broadway Avenue basement will be disconnected from the electrical box in the basement prior to the start of this project.
16. The opening at the drive through window and the doorway to the building's basement in the underground parking garage are to be abandoned according to the attached sketch from the structural engineer. This detail will be added to the construction set of plans. These abandonments will be paid for using the concrete structures pay item. The cost of the required rebar and post applied waterstop by Durajoint (Type 12 RT) to be installed around the perimeter of the opening shall be incidental to the concrete structures pay item.
17. A pay item has been added for 77 S. Broadway Avenue interior building demolition. The attached sketch details the demolition location and items while the special provision below lists the requested activities.
18. The contractor to protect brick above upper parking deck from being damaged during removal of the deck. The City will provide replacement bricks for the contractor to install for any damaged bricks. This installation of replacement bricks shall be paid for at the contract unit price of SQUARE FOOT for INSTALL FURNISHED BRICK which price shall include all labor, material and equipment required to perform the work as specified herein.
19. The contractor shall install common brick in place of the upper parking deck concrete edges adjacent to the brick walls along the north and south faces of the parking deck which are to be removed. The contractor shall be responsible for furnishing the common bricks to be installed at this location. This installation of common bricks shall be paid for at the contract unit price of SQUARE FOOT for FURNISH AND INSTALL COMMON BRICK which price shall include all labor, material and equipment required to perform the work as specified herein.
20. Special provisions for the foundation waterproofing, bollard, stairwell gate, and staircase railing are included with this addendum.
21. An updated schedule of prices is attached for the bidders use.

SP R.15 – FOUNDATION WATERPROOFING

This work shall consist of waterproofing exterior building faces composed of existing and proposed CMU block or concrete surfaces that are to be buried according to the plans and details.

This work shall be completed in accordance with article 503.18 of the Illinois Department of Transportation Standard Specifications for Road and Bridge Construction, latest edition. In addition, a geocomposite wall drain shall also be installed adjacent to the exterior building face to be buried. **The geocomposite wall drain shall extend a length of 2' horizontally away from and at the bottom elevation of the vertical wall to receiving waterproofing.** The cost of the geocomposite wall drain shall be included in the cost of FOUNDATION WATERPROOFING.

This work will be measured and paid for at the contract unit price per SQUARE FOOT for **FOUNDATION WATERPROOFING** of buried vertical wall face which price shall include all labor, material and equipment required to perform the work as specified herein.

77 S. BROADWAY AVE. PARKING STRUCTURE AND 65 WATER ST DEMOLITION PROJECT - ADDENDUM NO. 1

SP R.16 – BOLLARD

This work shall consist of installing a bollard in the proposed concrete flume similar to the existing bollard in the parking lot north of 65 Water Street.

The proposed concrete bollard shall be encased in a 6" diameter galvanized pipe. The pipe shall have a bury depth of 6' and shall have 3' of exposure above grade. A 15" diameter hole shall be excavated for the bollard base and the hole shall be backfilled with concrete.

This work will be measured and paid for at the contract unit price per EACH for **BOLLARD** which price shall include all labor, material and equipment required to perform the work as specified herein.

SP R.17 – EXTERIOR STAIR RAILING

This work shall consist of installing stair railing on the proposed concrete staircase located on the west side of 77 S. Broadway Avenue.

A stair railing shall be installed along the north and south edges of the concrete stairs. Each stair railing shall be a 36" tall Trex grip rail aluminum center handrail with a powdercoat finish or an engineer approved equal. The handrail shall be installed and mounted per manufacturer recommendations. Shop drawings shall be submitted for approval to the City prior to the purchase of the materials. The railing shall be paid for per foot with the length measured along the top railing not including the vertical supports.

This work will be measured and paid for at the contract unit price per FOOT for **EXTERIOR STAIR RAILING** which price shall include all labor, material and equipment required to perform the work as specified herein.

SP R.18 – STAIRWELL GATE

This work shall consist of installing a gate in the northeast stairwell of 77 S. Broadway Avenue at the Broadway Avenue street elevation restricting access to the lower level of the stairwell. The lower doorway in this stairwell below the elevation of Broadway Avenue is to be abandoned in preparation of the shear wall construction.

The gate shall be a 3' tall wrought iron gate with an access opening of at least 30". The gate shall have a maximum spacing of 4" between the vertical bars. Shop drawings shall be submitted for approval to the City prior to the purchase of the materials. The gate shall be paid for per foot with the length measured along the top railing of the gate.

This work will be measured and paid for at the contract unit price per FOOT for **STAIRWELL GATE** which price shall include all labor, material and equipment required to perform the work as specified herein.

SP R.19 – 77 S. BROADWAY AVENUE INTERIOR BUILDING DEMOLITION

This work shall consist of demolition of the areas depicted in the attached exhibit. The south wall, raised wooden platform, stairwell, and doorways of the old bank drive thru teller room shall be removed according to the attached plan.

**77 S. BROADWAY AVE. PARKING STRUCTURE AND 65 WATER ST DEMOLITION
PROJECT - ADDENDUM NO. 1**

This work will be measured and paid for at the contract unit price per LUMP SUM for 77 S.
BROADWAY AVENUE INTERIOR BUILDING DEMOLITION which price shall include all
labor, material and equipment required to perform the work as specified herein.

Sincerely,

KM

Kurt Muth, P.E.
Professional Engineer
City of Aurora Engineering Division

**PLEASE ACKNOWLEDGE RECEIPT OF THIS ADDENDUM BY FILLING OUT THE
FOLLOWING AND SENDING AN ORIGINAL OR FAX COPY OF THIS SHEET TO
THE CITY OF AURORA ENGINEERING DIVISION AT 630/256-3229 OR
PREFERRABLY BY E-MAIL AT kmuth@aurora-il.org IMMEDIATELY UPON
RECIPT.**

COMPANY NAME PERFORMANCE CONSTRUCTION & ENG., LLC

SIGNATURE OF COMPANY REPRESENTATIVE *[Signature]*



Schedule of Prices
77 S. Broadway Ave. Parking Structure
& 65 Water St Demolition Project
B18-23

Route S. Broadway Ave. & Water St.
 County Kane
 Local Agency City of Aurora

RETURN WITH BID

Addendum No. 1

(For complete information covering these items, see plans and specifications)

NO.	ITEM	UNIT	QUANTITY	UNIT COST	AMOUNT
1	6' Chain Link Temporary Construction Perimeter Fence	FT	800		
2	Tree removal (6-15 units)	UNIT	6		
3	65 Water St Trash Enclosure Fence Removal	LS	1		
4	Curb and Gutter Removal	FT	150		
5	Sidewalk Removal (Adjacent to 65 Water St)	SF	1,000		
6	Light Pole Foundation Removal (65 Water St)	EA	1		
7	65 Water Street Building Demolition	LS	1		
8	77 S. Broadway Avenue Parking Structure Demolition	LS	1		
9	77 S. Broadway Avenue Interior Building Demolition	LS	1		
10	Communications Service Conduit Installation & Wall Bracing	FT	60		
11	Excavation for Structural Concrete	CY	30		
12	Concrete Structures	CY	70		
13	Exterior Stair Railing, 3' Tall	FT	20		
14	Stairwell Gate	FT	4		
15	Removal of Cladding on Three East Columns	LS	1		
16	Fill Drive Trough Tunnel	CY	35		
17	Masonry Wall (NE stairwell doorways, Non-structural)	SF	60		
18	Foundation Waterproofing	SF	2,400		
19	Drain Tile, 6" Perforated PVC SDR-26	FT	350		
20	Connect drain tiles with 6" Wye connection	EA	1		
21	Connect proposed underdrain to existing storm sewer	EA	2		
22	Aggregate Base Course, Tye A, 12"	SY	900		
23	Bituminous Materials (Prime Coat)	GAL	600		
24	Hot Mix Asphalt, Binder Course, N50, 2.5"	TON	208		
25	Hot Mix Asphalt, Surface Course, N50, 1-1/2"	TON	80		
26	Class D Patching, 10"	SY	50		

NO.	ITEM	UNIT	QUANTITY	UNIT COST	AMOUNT
27	Surface Course Removal	SY	20		
28	6" PCC Barrier Curb	FT	110		
29	10" PCC Barrier Curb	FT	60		
30	Concrete Flume, 6" Thick	SF	25		
31	Install Furnished Brick	SF	250		
32	Furnish and Install Common Brick	SF	500		
33	Bollard, 6" Dia., 6' tall, 3' Bury	EA	1		
34	Bollard Removal	EA	2		
35	Concrete Apron Removal	SY	25		
36	Combination PCC Curb & Gutter Removal and Replacement	FT	210		
37	Decorative Fence, 4'	FT	110		
38	PCC Sidewalk Rem. and Replace, 5"	SF	2,000		
39	PCC Sidewalk, 5" w/Welded Wire Fabric & Aggregate Base	SF	2,050		
40	Detectable Warnings	SF	100		
41	Brick Ribbon Removal and Replacement	SF	330		
42	Brick Ribbon Installation	SF	180		
43	Seal Coat	SY	450		
44	Paint Pavement Marking - Line, 4"	FT	1,500		
45	Paint Pavement Marking - Letters & Symbols	SF	55		
46	Topsoil, 6" (Landscape Islands only)	SY	140		
47	Seeding - Aurora Mix	SY	2,000		
48	Items Ordered by Engineer	Allowance	1	\$50,000.00	\$50,000.00
49	Traffic Control and Protection	LS	1		
50	Inlet Protection	EACH	5		
51	Silt Fence	FT	60		
52	Dewatering Bag	EACH	1		
Bidder's Total Proposal for Making Base Bid Improvements (Addendum No. 1) =					

City of Aurora
77 S. Broadway Ave. Parking Structure & 65 Water St. Demolition Project
Mandatory Pre-Bid Meeting Outline
Aurora City Hall, 44 E. Downer Place, Aurora IL 60507
March 21st, 10:30 A.M. CST

1. The minutes from this meeting will be distributed via an addendum.
2. Bids are due to the City Clerk by 2:00 P.M. CST, March 28th, 2018.
3. IDOT Prequalification, as mentioned in bidder instruction item 3 of the advertisement, will be not be required for this project.
4. Anticipated contract approval is currently the City Council meeting on April 24th.
5. There are 50 Working Days to achieve Substantial Completion which starts with the execution of the contract or 15 days from the Notice to Proceed (Anticipated 4/24), whichever occurs first.
6. Project Limitations and Work Restrictions:
 - a. Full closure of Water Street to be limited to one week.
 - b. Closure of the parking lot on the North side of 65 Water Street shall be limited to one week.
 - c. Closure of the parking module (two rows of parking and aisle) on the South side of 65 Water Street shall be allowed for the duration of the project to be used as storage and staging.
 - d. Closure of northbound Water Street during the demolition of the west side of the parking garage should be kept to a minimum.
 - e. Flaggers should be utilized as necessary when crossing Water Street outside of any closures.
 - f. Detour routes utilizing Stolp Avenue will be required for any lane closures of Water Street.
 - g. Trucks shall enter and exit the site via Benton Street; construction traffic shall not utilize Downer Place.
7. All material left onsite shall be in general accordance with CCDD acceptable fill and shall generally be minus 6"; no pieces larger than 1' will be allowed. Materials that are not in conformance with general CCDD guidelines shall be removed and recycled or removed and transported to an appropriate landfill by the contractor (included in the cost of the demolition). Any equipment and efforts required to meet the size requirements shall be included in the cost of the demolition.
8. The contractor shall provide continual dust control during the demolition; debris outside the limit of construction fencing shall be addressed immediately and not only at the end of the day. If the contractor intends to use water to control the dust, a meter shall be obtained per the protocol outlined in the specifications; the cost of any water used shall be considered included in the cost of the demolition.
9. An addendum is forthcoming, which will contain details for a bollard, a gate in the northeast stairwell and an exterior staircase railing.
10. Doorways in northeast stairwell are to be abandoned with the Masonry Wall pay item.
11. The City is currently coordinating the relocation of the gas meter with Nicor. It is anticipated that at least a portion of the demolition will need to be completed prior to relocating the meter.
12. The Contractor will be required to protect the existing AT&T line in the parking garage during demolition.
13. The City will provide final grades for 65 Water Street once the building is removed; the final pavement grade will match the existing adjacent lots to the north and south.
14. 65 Water Street to be excavated down to proposed pavement subgrade elevation and any footings to be removed to at least that elevation.
15. The pavement section at 65 Water Street will be 12" aggregate base course, 2.5" binder course, & 1.5" surface course. The binder course thickness will be revised in the schedule of prices.
16. The concrete entrance to the parking structure ramp on Benton is to be removed. The schedule of prices will be updated to include the necessary bid items and quantities.
17. The City will be adding some internal demolition work at 77 S. Broadway Avenue inside the bank teller window. More detail will be provided with the addendum.

City of Aurora
 77 S. Broadway Ave & 65 Water Street Demolition Project
 Mandatory Pre-Bid Meeting
 3/21/18

Sign-In Sheet

Name	Organization	Number
Kurt Muth	City of Aurora	630-256-3200
Jason Bauer	City of Aurora	630-256-3200
JOHN FRANKLIN MIGUEL VAZQUEZ	HTE	620-513-6711
MIKE NOWCZUK	FH PASCHEN	773-251-0251
LEWIS GIBBON &	Spirit Wrecking ^{EXCAVATION}	630-297-1460
BETTY BREWER	EUC DEMOLITION	708 532 7007
Bill Handt	Alliance Concrete Sawing	847-878-7695
JAMES O'CONNELL	DORE ASSOC. CONTRACTING	989-684-8358
Bobby Myagmar	BBB Construction Corp.	878-218-0872
PETER LEHOTAN	KLF ENTERPRISES	773-640-1104
GLENN LEMPA	MIDWEST WRECKING	312-666-1043
Jurgen Corabuz	American Demolition	708 847-456-1279
TERRY SEWELLS	RCW SCRAP	630-844-3000
Steve Linden	H. Linden & Sons	630-552-9955
Chris Lump	Alpine demolition	630-470-1644
Jeremy Thord	Heneghan Wrecking	773-617-8242

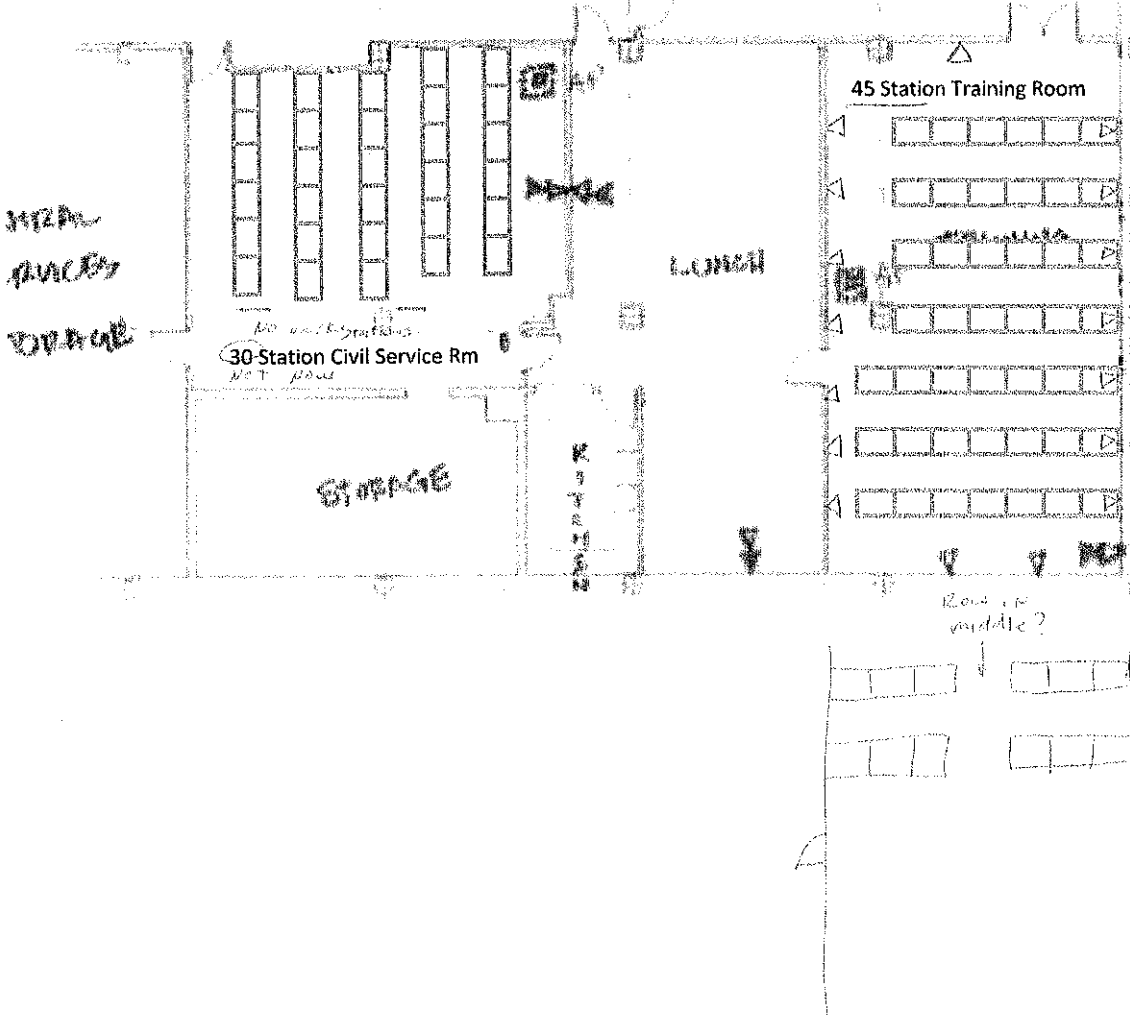
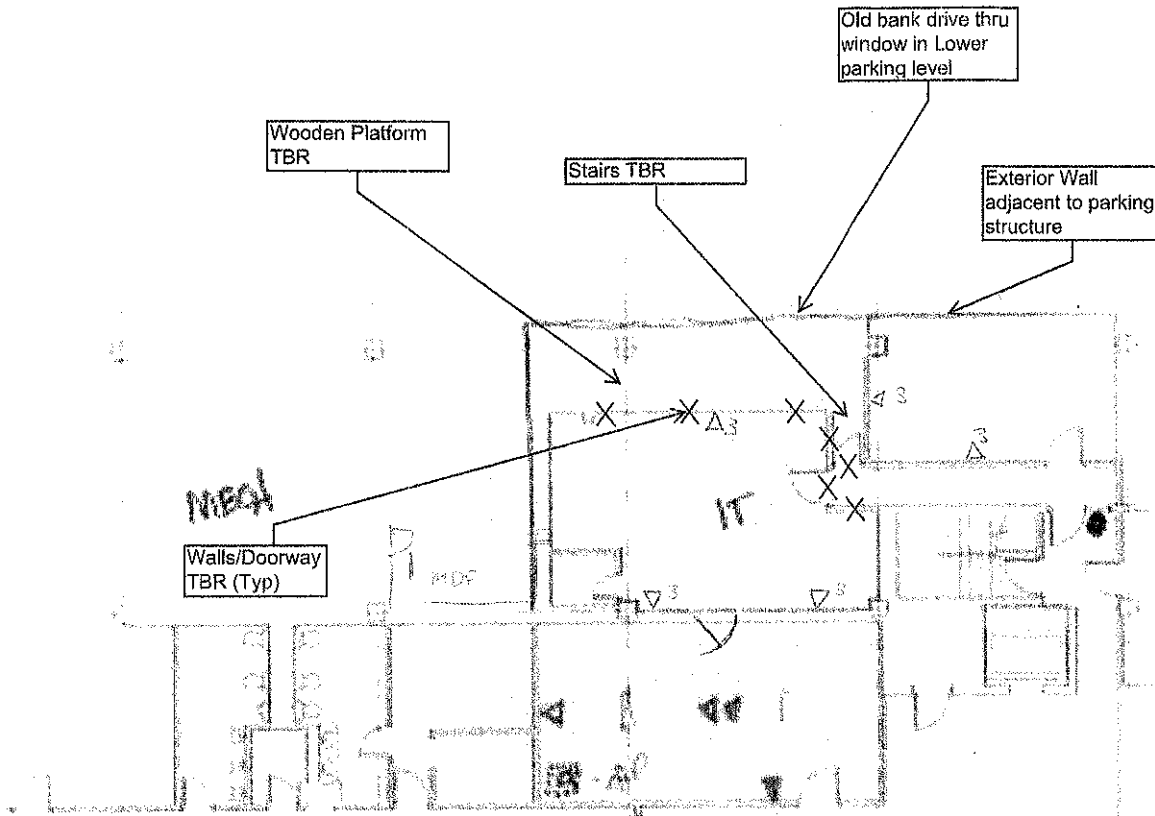

City of Aurora, IL - Bid 18-23 Addendum No. 2

Coulter, Jolene <JCoulter@aurora-il.org>

Fri, Mar 30, 2018 at 7:47 AM

Good morning,

The City of Aurora, IL posted the attached addendum to the City's website late yesterday.

Sealed bids will be accepted **prior to 2:00 pm, Monday, April 2, 2018** at:

City of Aurora, IL
Attn: City Clerk's Office, 2nd floor
44 E. Downer Place
Aurora, IL 60507

We look forward to receiving your bids.

Sincerely,

Jolene Coulter

Director of Purchasing

44 E. Downer Place

Aurora, IL 60507

Ph) 630-256-3550

Fx) 630-256-3559

The City of Aurora offers electronic funds transfer (EFT) payment to our vendors.

EFT is fast, simple, safe and secure and is *our preferred method of payment!*

Please contact the Purchasing Office to get signed up.

B18-23

**77 S. Broadway Ave Parking Structure and 65 Water St Demolition Project
Bid opening – ~~March 28, 2018~~ April 2, 2018 @ 2 p.m.**

ADDENDUM NO. 2

Page 1 of 4

TO: All Bidders

FROM: Engineering Division, City of Aurora

DATE: March 29, 2018

THIS ADDENDUM FORMS A PART OF THE BIDDING AND CONTRACT DOCUMENTS.

1. The structural concrete details for the drive thru window and underground garage basement door abandonment were omitted from Addendum no. 1. They are attached to this addendum.
2. Pavement marking removal and temporary pavement marking referenced in the traffic control and protection special provision will not be required for this project and are not listed in the schedule of prices.
3. Select granular backfill will not be required for this project and is not listed in the schedule of prices.
4. Compaction jetting and water soaking will not be required for this project.
5. Structure taps referred to the special provisions will not be required for this project.
6. Barrier curbs are to be constructed in accordance with the COMBINATION P.C.C. CURB & GUTTER special provision except without the gutter.
7. The SEEDING-AURORA MIX pay item is to cover restoration of all proposed non-hardscape surfaces on the 77 S. Broadway Avenue site. The special provision describes what items in addition to topsoil are included with this pay item. If portions of the 77 S. Broadway Avenue site do not achieve the proposed sub-grade elevation due to lack of fill material, then it is not expected to have the area restored.
8. The topsoil pay item is intended to be used for the proposed landscape islands at 65 Water Street which will not be seeding following topsoil place but planted by the City of Aurora.
9. Rough grading of the disturbed areas will be included in the cost of breakdown and placement of CCDD materials. Fine grading of 65 Water Street will be included in the Aggregate base course pay item. Fine grading of 77 S. Broadway Avenue will be included with the Seeding or hardscape surface pay items.

Sincerely,

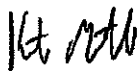

Kurt Muth, P.E.
Professional Engineer
City of Aurora Engineering Division

**77 S. BROADWAY AVE. PARKING STRUCTURE AND 65 WATER ST DEMOLITION
PROJECT - ADDENDUM NO. 2**

**PLEASE ACKNOWLEDGE RECEIPT OF THIS ADDENDUM BY FILLING OUT THE
FOLLOWING AND SENDING AN ORIGINAL OR FAX COPY OF THIS SHEET TO
THE CITY OF AURORA ENGINEERING DIVISION AT 630/256-3229 OR
PREFERRABLY BY E-MAIL AT kmuth@aurora-il.org IMMEDIATELY UPON
RECIPT.**

COMPANY NAME Performance Construction & Eng., LLC

SIGNATURE OF COMPANY REPRESENTATIVE 

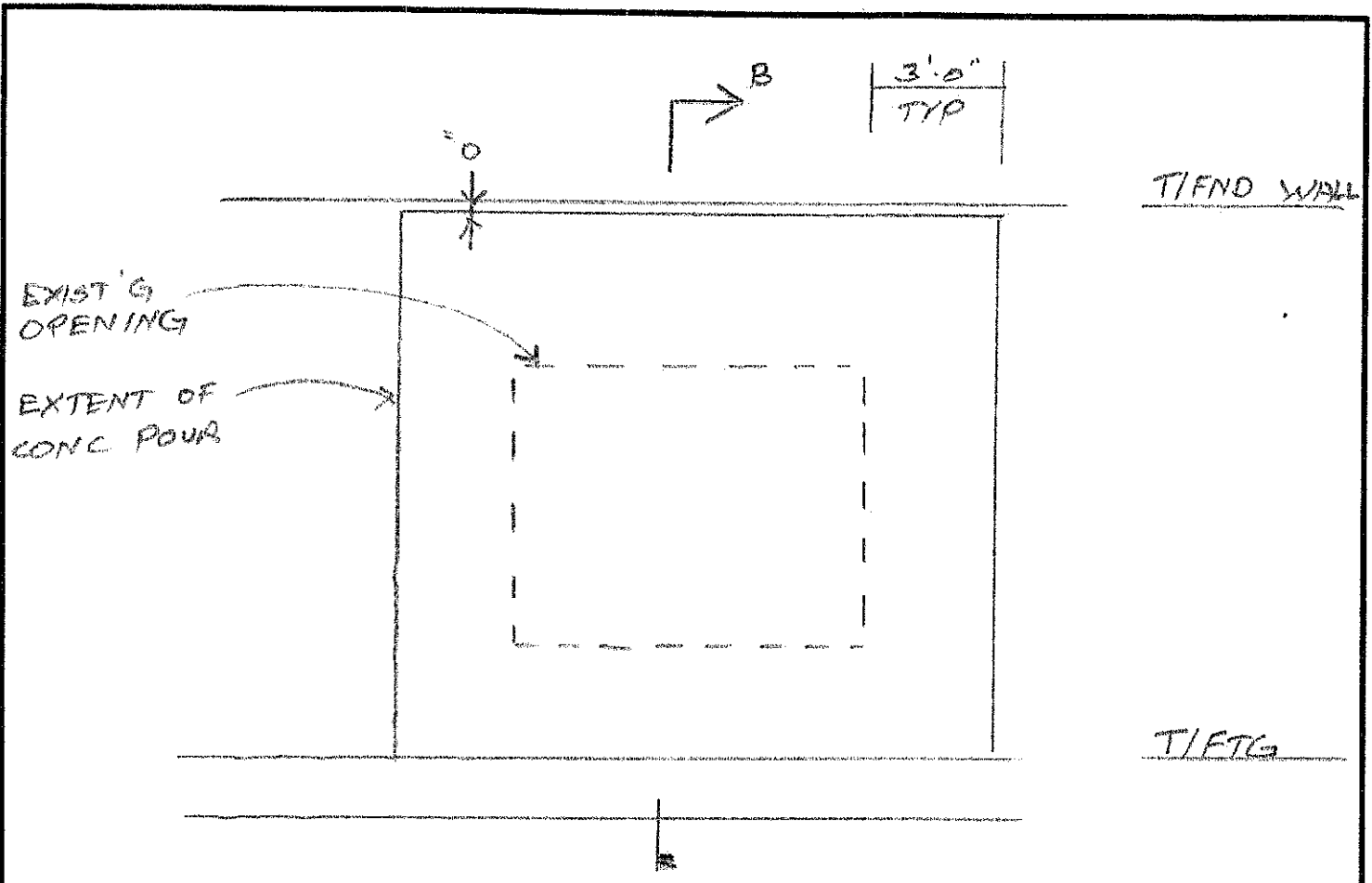

A CONCRETE IN-FILL AT GARAGE
MAN DOOR & DRIVE THRU OPENING

**HUTTER
 TRANKINA
 ENGINEERING, PC**

Consulting Structural Engineers
 32 W 273 ARMY TRAIL ROAD
 SUITE # 100
 WAYNE, ILLINOIS 60184
 Phone (630) 513-6711

JOB 77 S BROADWAY
 SHEET NO. SK #1 OF _____
 CALCULATED BY _____ DATE _____
 CHECKED BY _____ DATE _____
 SCALE _____

T/FIRST FLR

T/OPENING

#4 DOWEL @ 24" O.C
AROUND PERIM.
PROVIDE HILTI EPOXY
HIT RE 500 W/ 3"
EMBED

7"
18"

POST APPLIED WATERSTOP BY
DURRAJOINT: TYPE 12 RT

0" ← → 8"

WATER PROOF
AND WALL
DRAIN

B/OPENING

T/SLAB
VARIES

#5 @ 12" EACH
WAY

B OPENING IN-FILL

**HUTTER
TRANKINA
ENGINEERING, PC**

Consulting Structural Engineers
32 W 273 ARMY TRAIL ROAD
SUITE # 100
WAYNE, ILLINOIS 60184
Phone (630) 513-6711

JOB 77 S. BROADWAY

SHEET NO. SR 12 OF _____

CALCULATED BY _____ DATE _____

CHECKED BY _____ DATE _____

SCALE _____